

# ELECTRICAL SYSTEM

## SECTION **EL**

GI

MA

EM

LC

EF &  
EC

FE

CL

MT

AT

PD

FA

RA

BR

ST

BF

HA

**EL**

**When you read wiring diagrams:**

- Read GI section, "HOW TO READ WIRING DIAGRAMS".

## CONTENTS

<b>HARNESS CONNECTOR</b> .....	3	Daytime Light/Wiring Diagram.....	31
Description .....	3	Clearance, License, Tail and Stop Lamps/Wiring Diagram.....	32
<b>STANDARDIZED RELAY</b> .....	4	Back-up Lamp/Wiring Diagram .....	34
Description .....	4	Turn Signal and Hazard Warning Lamps/Wiring Diagram.....	35
<b>POWER SUPPLY ROUTING</b> .....	6	Combination Flasher Unit Check .....	36
Wiring Diagram .....	6	Bulb Specifications .....	36
Fuse .....	7	<b>INTERIOR LAMP</b> .....	37
Fusible Link.....	7	Illumination/Wiring Diagram .....	37
<b>BATTERY</b> .....	8	Interior Lamp/Wiring Diagram .....	38
How to Handle Battery.....	8	<b>METER AND GAUGES</b> .....	39
Service Data and Specifications (S.D.S.).....	11	Combination Meter .....	39
<b>STARTING SYSTEM</b> .....	12	Combination Meter/Wiring Diagram .....	42
Wiring Diagram .....	12	Speedometer, Tachometer, Temp. and Fuel Gauges/Wiring Diagram .....	43
Construction .....	13	Inspection/Fuel Gauge and Water Temperature Gauge.....	44
Service Data and Specifications (S.D.S.).....	13	Fuel Tank Gauge Unit Check .....	45
<b>CHARGING SYSTEM</b> .....	14	Thermal Transmitter Check.....	45
Wiring Diagram .....	14	Oil Pressure Switch Check.....	45
Construction .....	15	Speed Sensor Signal Check.....	45
Service Data and Specifications (S.D.S.).....	16	<b>WARNING LAMPS AND CHIME</b> .....	46
<b>COMBINATION SWITCH</b> .....	17	Warning Lamps/Schematic.....	46
Combination Switch/Check.....	17	Warning Lamps/Wiring Diagram.....	47
Replacement .....	18	Warning Chime/Wiring Diagram .....	48
Steering Switch/Check.....	19	Diode Check .....	49
<b>HEADLAMP</b> .....	20	Warning Chime Check .....	49
Schematic .....	20	<b>TIME CONTROL SYSTEM</b> .....	50
Wiring Diagram .....	21	Schematic .....	50
Description .....	22	Wiring Diagram .....	51
Constructions .....	26	Description .....	52
Assembly.....	27	Trouble-shooting .....	53
Installation and Adjustment.....	27	<b>WIPER AND WASHER</b> .....	59
Headlamp Motor Check .....	28		851
Aiming Adjustment.....	29		
<b>EXTERIOR LAMP</b> .....	30		
Daytime Light/Description & Schematic.....	30		

# CONTENTS (Cont'd.)

Front Wiper and Washer/Wiring Diagram .....	59	Wiring Diagram .....	72
Rear Wiper and Washer/Wiring Diagram .....	60	Schematic .....	74
Wiper and Washer Adjustment .....	61	Trouble Diagnoses .....	75
Washer Nozzle Adjustment .....	62	A.S.C.D. Wire Adjustment .....	83
Check Valve .....	62	<b>LOCATION OF ELECTRICAL UNITS</b> .....	87
Wiper Amplifier Check .....	63	Engine Compartment .....	87
<b>HORN, CIGARETTE LIGHTER AND CLOCK</b> .....	64	Passenger Compartment .....	88
Wiring Diagram .....	64	<b>HARNES LAYOUT</b> .....	90
<b>REAR WINDOW DEFOGGER</b> .....	65	Outline .....	90
Wiring Diagram .....	65	Instrument Harness .....	91
Filament Check .....	66	Back Door Harness .....	91
Filament Repair .....	67	Main Harness .....	92
<b>AUDIO AND POWER ANTENNA</b> .....	68	Engine Room Harness .....	98
Audio/Wiring Diagram .....	68	Engine Room Harness No. 2 .....	101
Power Antenna/Wiring Diagram .....	69	E.F.I. Harness .....	102
Radio Fuse Check .....	69	Room Lamp and Sun Roof Harness .....	103
Location of Antenna .....	70	Door Harness L.H. ....	104
Antenna Rod Replacement .....	70	Door Harness R.H. ....	104
Window Antenna Repair .....	71	<b>SUPER MULTIPLE JUNCTION (S.M.J.)</b> .....	105
<b>AUTOMATIC SPEED CONTROL DEVICE</b> <b>(A.S.C.D.)</b> .....	72	Disconnecting and Connecting .....	105
		Terminal Arrangement .....	106

## WIRING DIAGRAM REFERENCE CHART

ECCS .....	FOLDOUT PAGE
A/T CONTROL, SHIFT LOCK CONTROL .....	AT SECTION
ANTI-LOCK BRAKING SYSTEM .....	BR SECTION
SUPER HICAS SYSTEM .....	ST SECTION
ELECTRIC DOOR MIRROR, SUN ROOF, DOOR LOCK, POWER WINDOW AND AUTOMATIC SEAT BELT .....	BF SECTION
HEATER AND AIR CONDITIONER .....	HA SECTION

# HARNESS CONNECTOR

## Description

### HARNESS CONNECTOR

- All harness connectors have been modified to prevent accidental looseness or disconnection.
- The connector can be disconnected by pushing or lifting the locking section.

#### CAUTION:

Do not pull the harness when disconnecting the connector.

[Example]

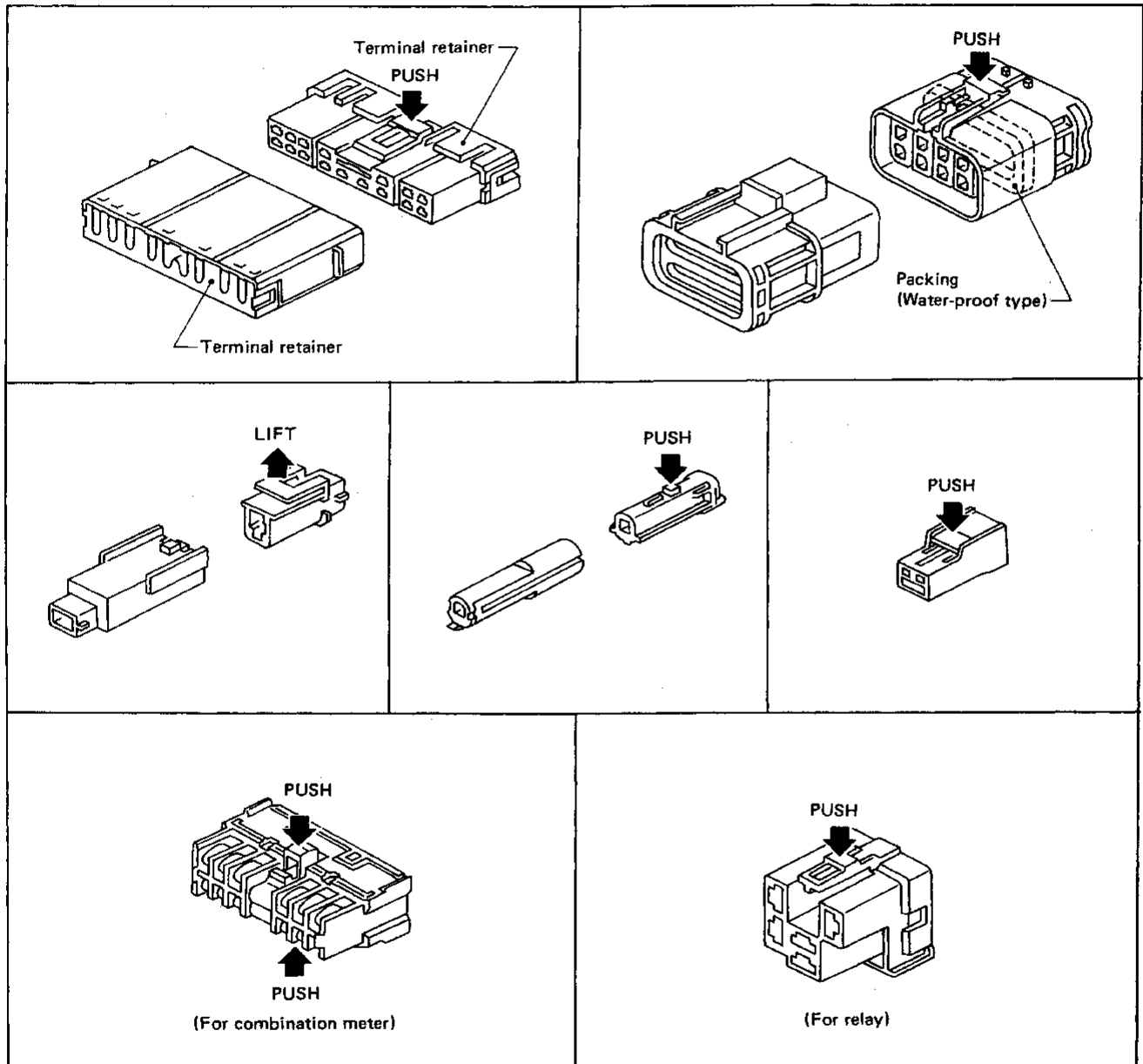

GI

MA

EM

LC

EF &  
EC

FE

CL

MT

AT

PD

FA

RA

BR

ST

BF

HA

EL

SEL769D

# STANDARDIZED RELAY

## Description

### NORMAL OPEN, NORMAL CLOSED AND MIXED TYPE RELAYS

Relays can mainly be divided into three types: normal open, normal closed and mixed type relays.

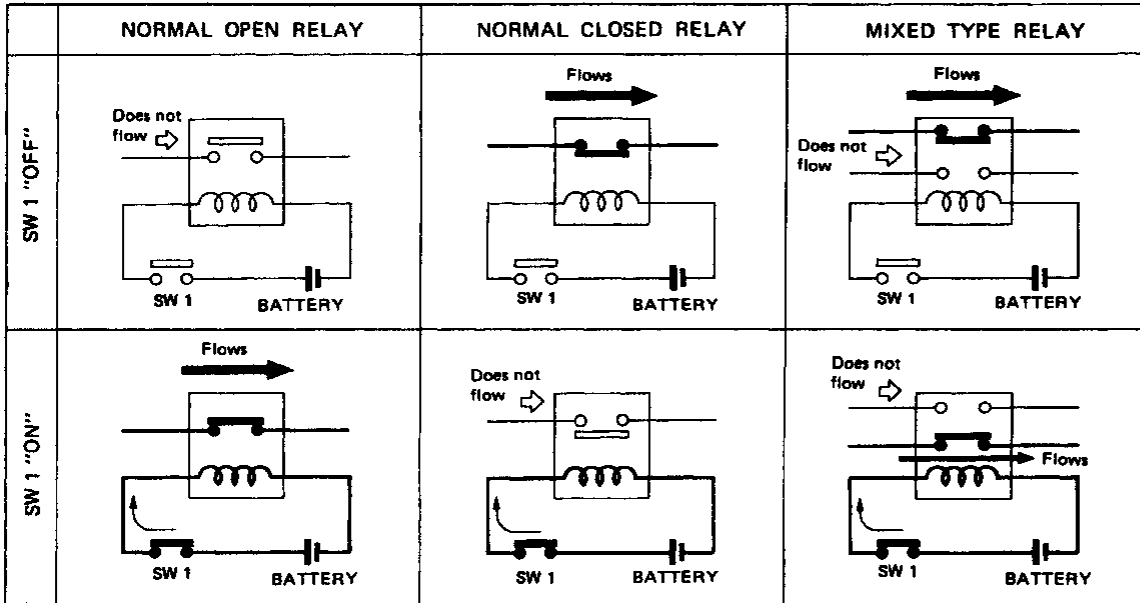

SEL881H

### TYPE OF STANDARDIZED RELAY

1M ... 1 Make

2M ... 2 Make

1T ... 1 Transfer

1M-1B ... 1 Make 1 Break

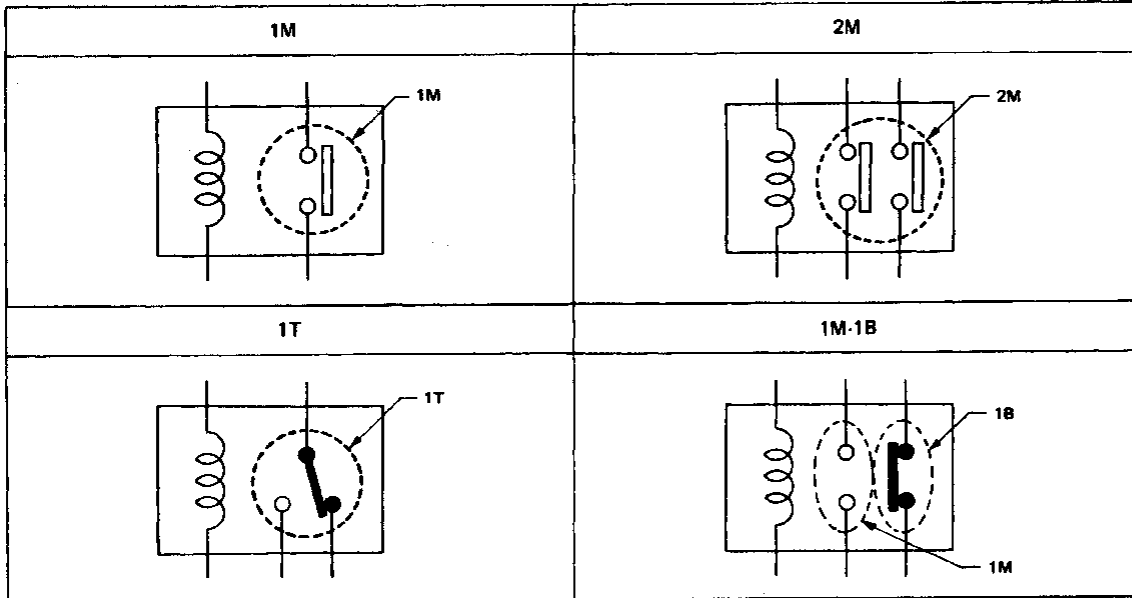

SEL882H

# STANDARDIZED RELAY

## Description (Cont'd)

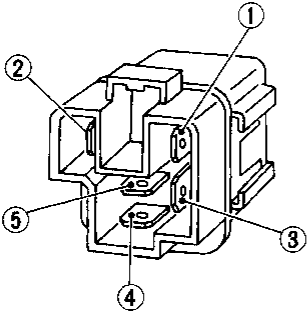
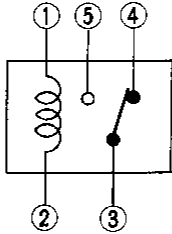
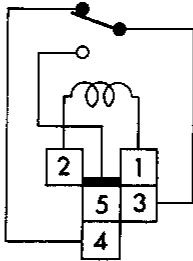
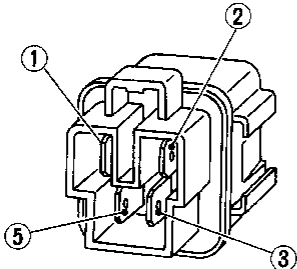
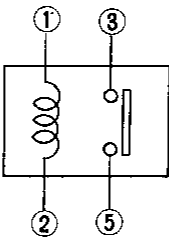
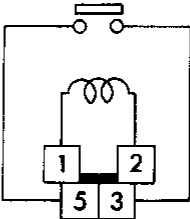
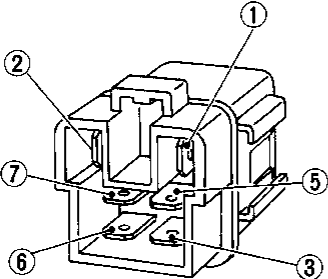
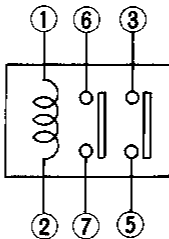
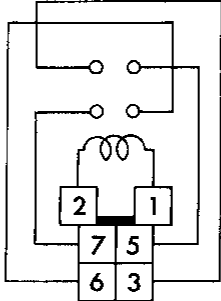
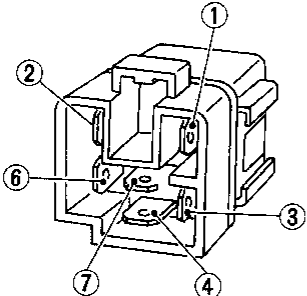
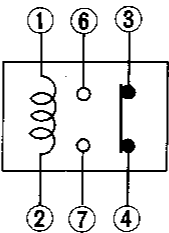
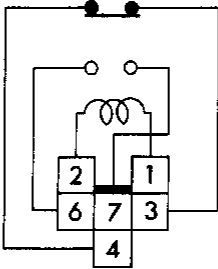
Type	Outer view	Circuit	Connector symbol and connection	Case color
1T				BLACK
1M				BLUE or GREEN
2M				BROWN
1M-1B				GRAY

GI

MA

EM

LC

EF &  
EC

FE

CL

MT

AT

PD

FA

RA

BR

ST

BF

HA

EL

# POWER SUPPLY ROUTING

## Wiring Diagram

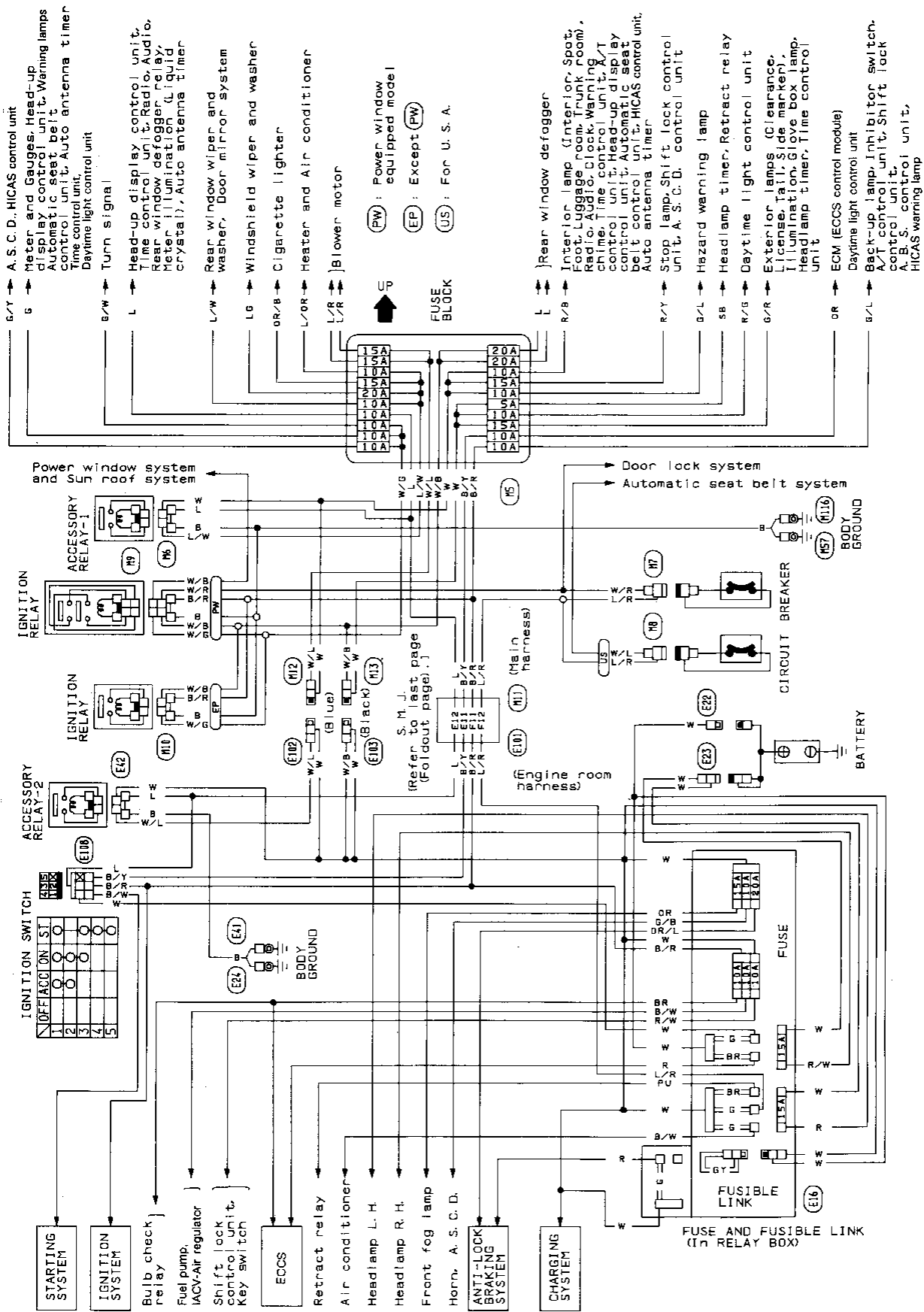

# POWER SUPPLY ROUTING

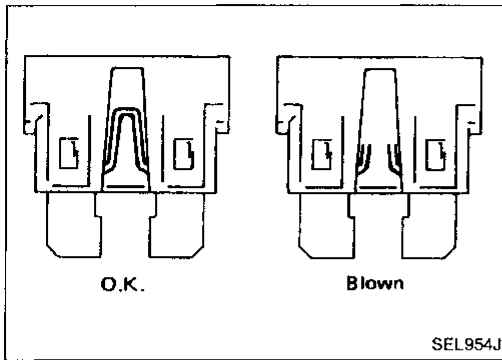

## Fuse

- If fuse is blown, be sure to eliminate cause of problem before installing new fuse.
- Use fuse of specified rating. Never use fuse of more than specified rating.
- Do not install fuse in oblique direction; always insert it into fuse holder properly.
- Remove fuse for clock if vehicle is not used for a long period of time.

GI  
MA  
EM

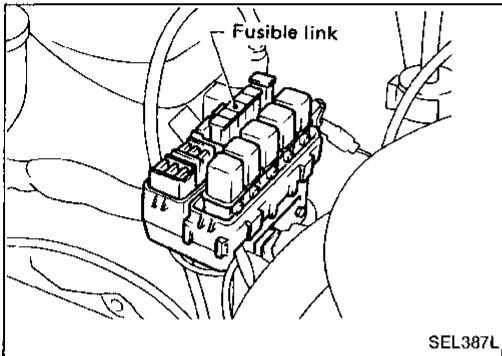

## Fusible Link

A melted fusible link can be detected either by visual inspection or by feeling with finger tip. If its condition is questionable, use circuit tester or test lamp.

### CAUTION:

- If fusible link should melt, it is possible that critical circuit (power supply or large current carrying circuit) is shorted. In such a case, carefully check and eliminate cause of problem.
- Never wrap periphery of fusible link with vinyl tape. Extreme care should be taken with this link to ensure that it does not come into contact with any other wiring harness or vinyl or rubber parts.

LC  
EF &  
EC  
FE  
CL  
MT  
AT  
PD  
FA  
RA  
BR  
ST  
BF  
HA

EL

# BATTERY

## CAUTION:

- If it becomes necessary to start the engine with a booster battery and jumper cables, use a 12-volt booster battery.
- After connecting battery cables, ensure that they are tightly clamped to battery terminals for good contact.
- Never add distilled water through the hole used to check specific gravity.

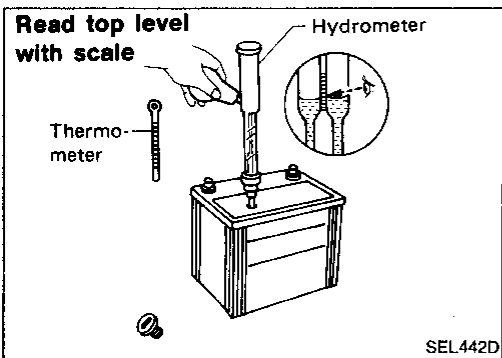
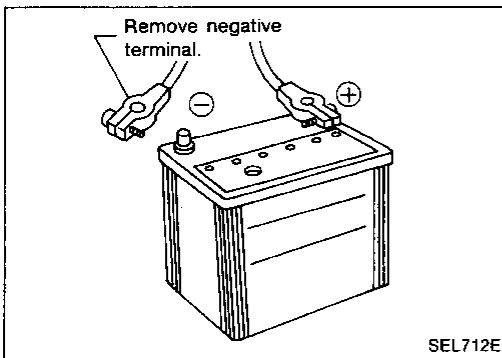
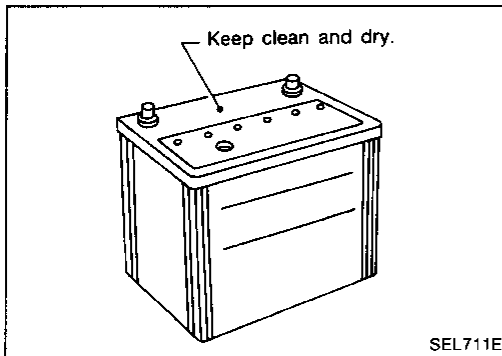

## How to Handle Battery

### METHODS OF PREVENTING OVER-DISCHARGE

The following precautions must be taken to prevent over-discharging a battery.

- The battery surface (particularly its top) should always be kept clean and dry.
  - The terminal connections should be clean and tight.
  - At every routine maintenance, check the electrolyte level.
- 
- When the vehicle is not going to be used over a long period of time, disconnect the negative battery terminal. (If the vehicle has an extended storage switch, turn it off.)

- Check the charge condition of the battery. Periodically check the specific gravity of the electrolyte. Keep a close check on charge condition to prevent over-discharge.

## CHECKING ELECTROLYTE LEVEL

### WARNING:

Do not allow battery fluid to come in contact with skin, eyes, fabrics, or painted surfaces. After touching a battery, do not touch or rub your eyes until you have thoroughly washed your hands. If the acid contacts the eyes, skin or clothing, immediately flush with water for 15 minutes and seek medical attention.



# BATTERY

## How to Handle Battery (Cont'd)

- Remove the cell plug using a suitable tool.
- Add distilled water up to the "MAX" level.

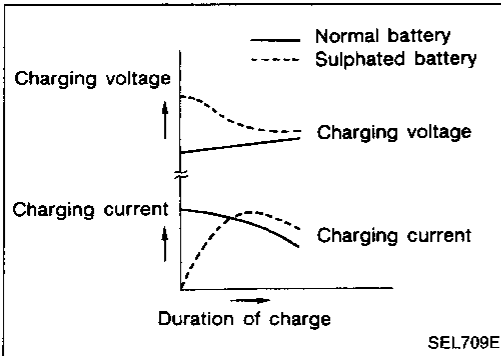
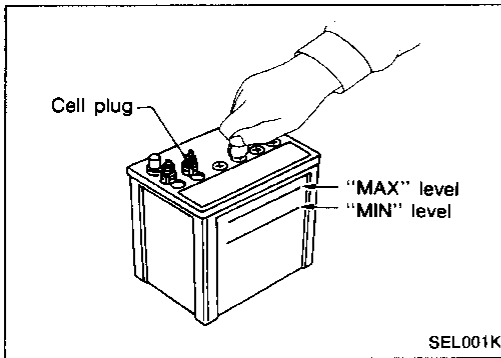

### SULPHATION

When a battery has been left unattended for a long period of time and has a specific gravity of less than 1.100, it will be completely discharged, resulting in sulphation on the cell plates.

Compared with a battery discharged under normal conditions, the current flow in a "sulphated" battery is not as smooth although its voltage is high during the initial stage of charging, as shown in the figure at the left.

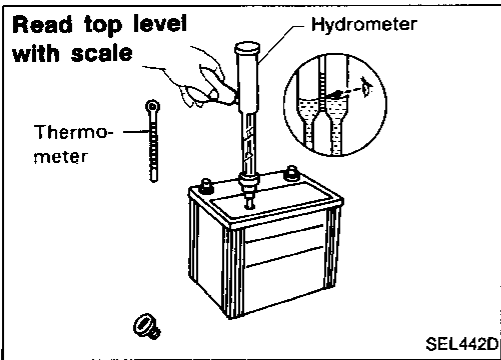

### SPECIFIC GRAVITY CHECK

1. Read hydrometer and thermometer indications at eye level.

GI

MA

EM

LC

EF &  
EC

FE

CL

MT

AT

PD

FA

RA

BR

ST

BF

HA

EL

# BATTERY

## How to Handle Battery (Cont'd)

- Use the chart below to correct your hydrometer reading according to electrolyte temperature.

### Hydrometer temperature correction

Battery electrolyte temperature °C (°F)	Add to specific gravity reading
71 (160)	0.032
66 (150)	0.028
60 (140)	0.024
54 (129)	0.020
49 (120)	0.016
43 (110)	0.012
38 (100)	0.008
32 (90)	0.004
27 (80)	0
21 (70)	-0.004
16 (60)	-0.008
10 (50)	-0.012
4 (39)	-0.016
-1 (30)	-0.020
-7 (20)	-0.024
-12 (10)	-0.028
-18 (0)	-0.032

Corrected specific gravity	Approximate charge condition
1.260 - 1.280	Fully charged
1.230 - 1.250	3/4 charged
1.200 - 1.220	1/2 charged
1.170 - 1.190	1/4 charged
1.140 - 1.160	Almost discharged
1.110 - 1.130	Completely discharged

## CHARGING THE BATTERY

### CAUTION:

- Do not "quick charge" a fully discharged battery.
- Keep the battery away from open flame while it is being charged.
- When connecting the charger, connect the leads first, then turn on the charger. Do not turn on the charger first, as this may cause a spark.
- If battery electrolyte temperature rises above 60°C (140°F), stop charging. Always charge battery at a temperature below 60°C (140°F).

### Charging rates:

Amps	Time
50	1 hour
25	2 hours
10	5 hours
5	10 hours

## BATTERY

### How to Handle Battery (Cont'd)

Do not charge at more than 50 ampere rate.

**Note:** The ammeter reading on your battery charger will automatically decrease as the battery charges. This indicates that the voltage of the battery is increasing normally as the state of charge improves. The charging amps indicated above refer to initial charge rate.

- If, after charging, the specific gravity of any two cells varies more than .050, the battery should be replaced.

### Service Data and Specifications (S.D.S.)

Applied area		U.S.A.	Canada
Type		55D23R	65D26R
Capacity	V-AH	12-60	12-65
Cold cranking current (For reference value)	A	356	413

GI

MA

EM

LC

EF &  
EC

FE

CL

MT

AT

PD

FA

RA

BR

ST

BF

HA

EL

# STARTING SYSTEM

## M/T MODEL

## Wiring Diagram

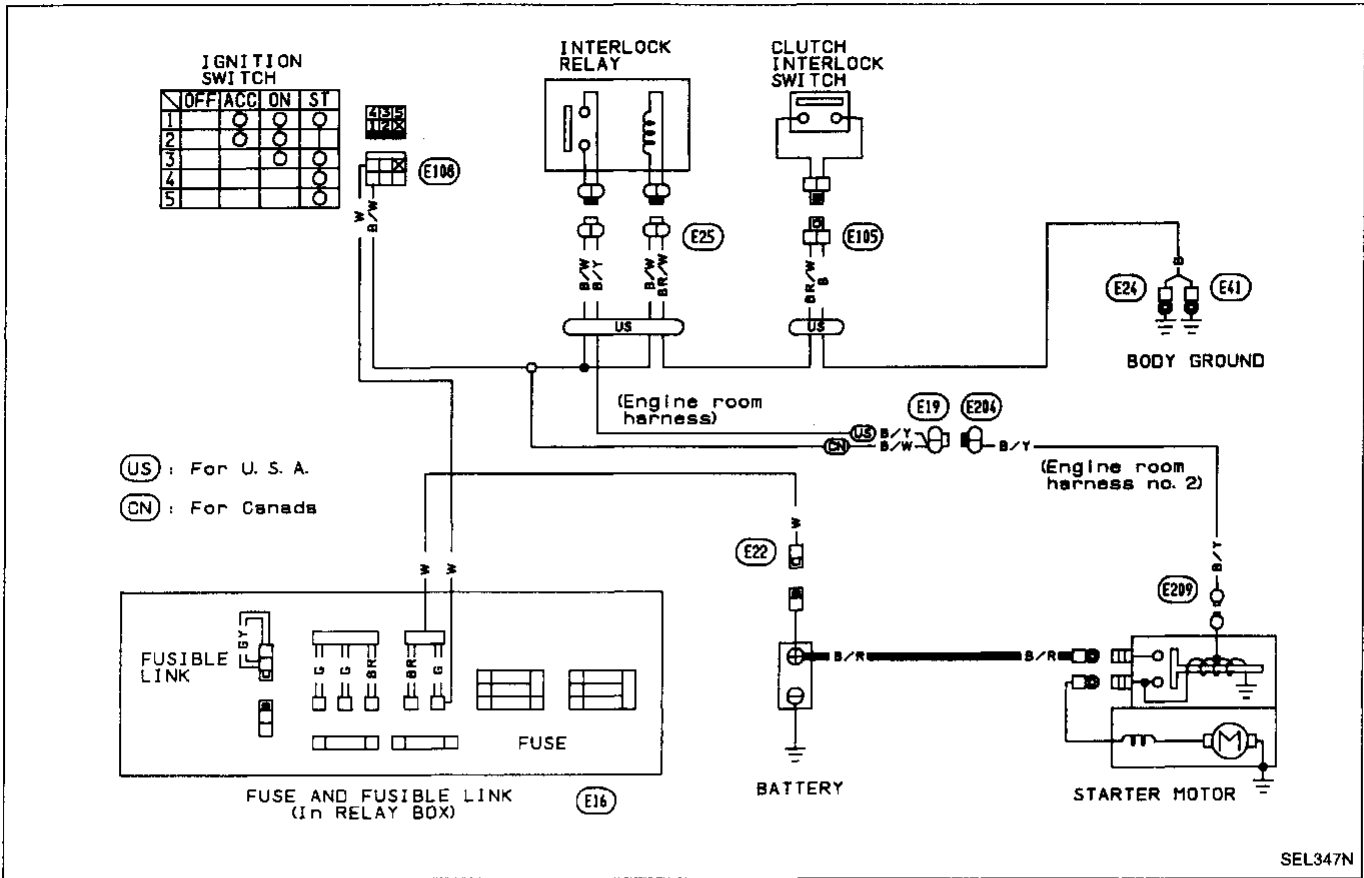

## A/T MODEL

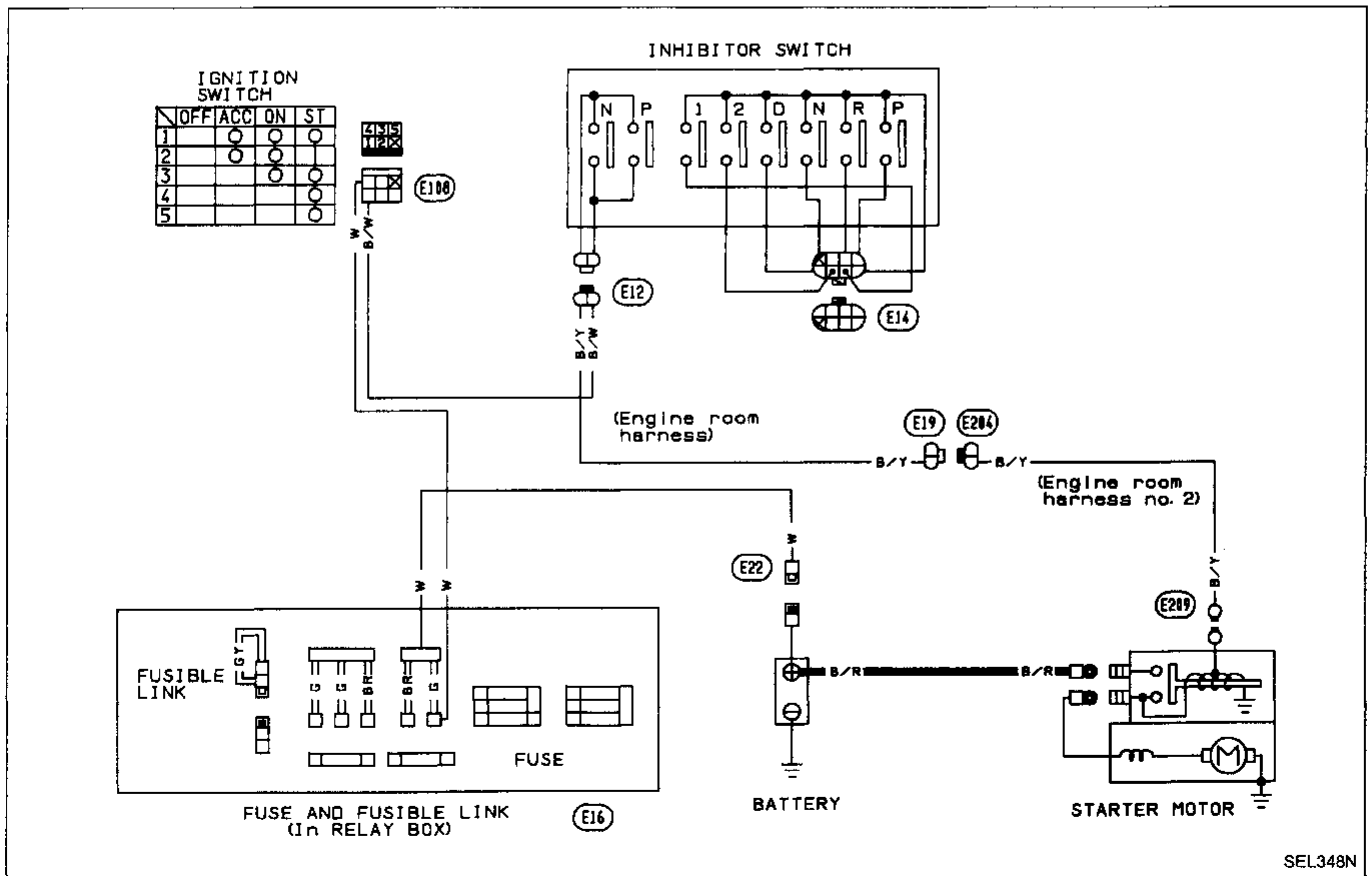

# STARTING SYSTEM

## Construction

M1T72781A

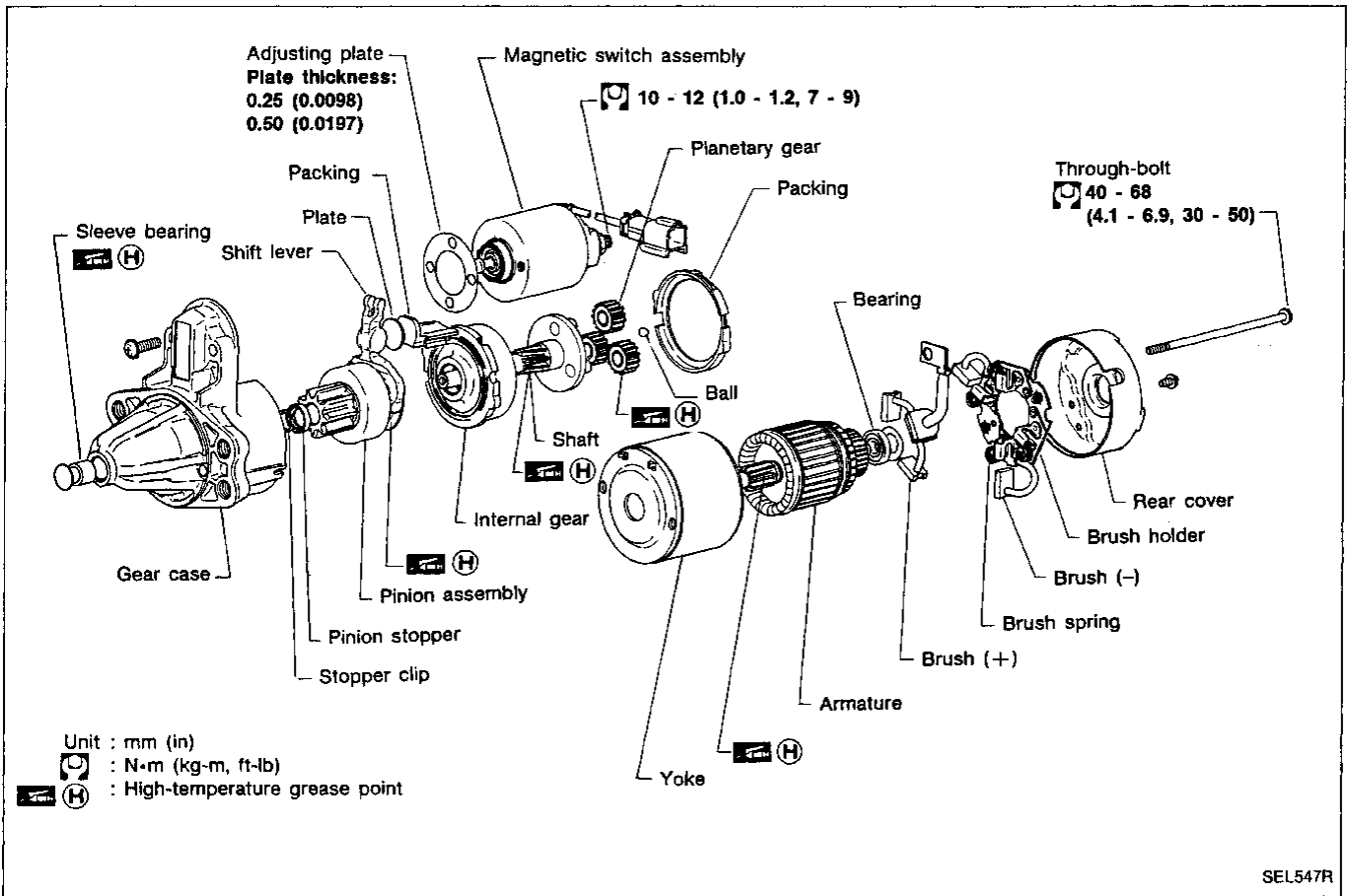

## Service Data and Specifications (S.D.S.)

### STARTER

Type	M1T72781A	
	MITSUBISHI make	
	Reduction gear type	
System voltage	V	12
No-load		
Terminal voltage	V	11.0
Current	A	50 - 75
Revolution	rpm	3,000 - 4,000
Minimum diameter of commutator	mm (in)	28.8 (1.134)
Minimum length of brush	mm (in)	12.0 (0.472)
Brush spring tension	N (kg, lb)	13.7 - 25.5 (1.4 - 2.6, 3.1 - 5.7)
Clearance between pinion front edge and pinion stopper	mm (in)	0.5 - 2.0 (0.020 - 0.079)

# CHARGING SYSTEM

## Wiring Diagram

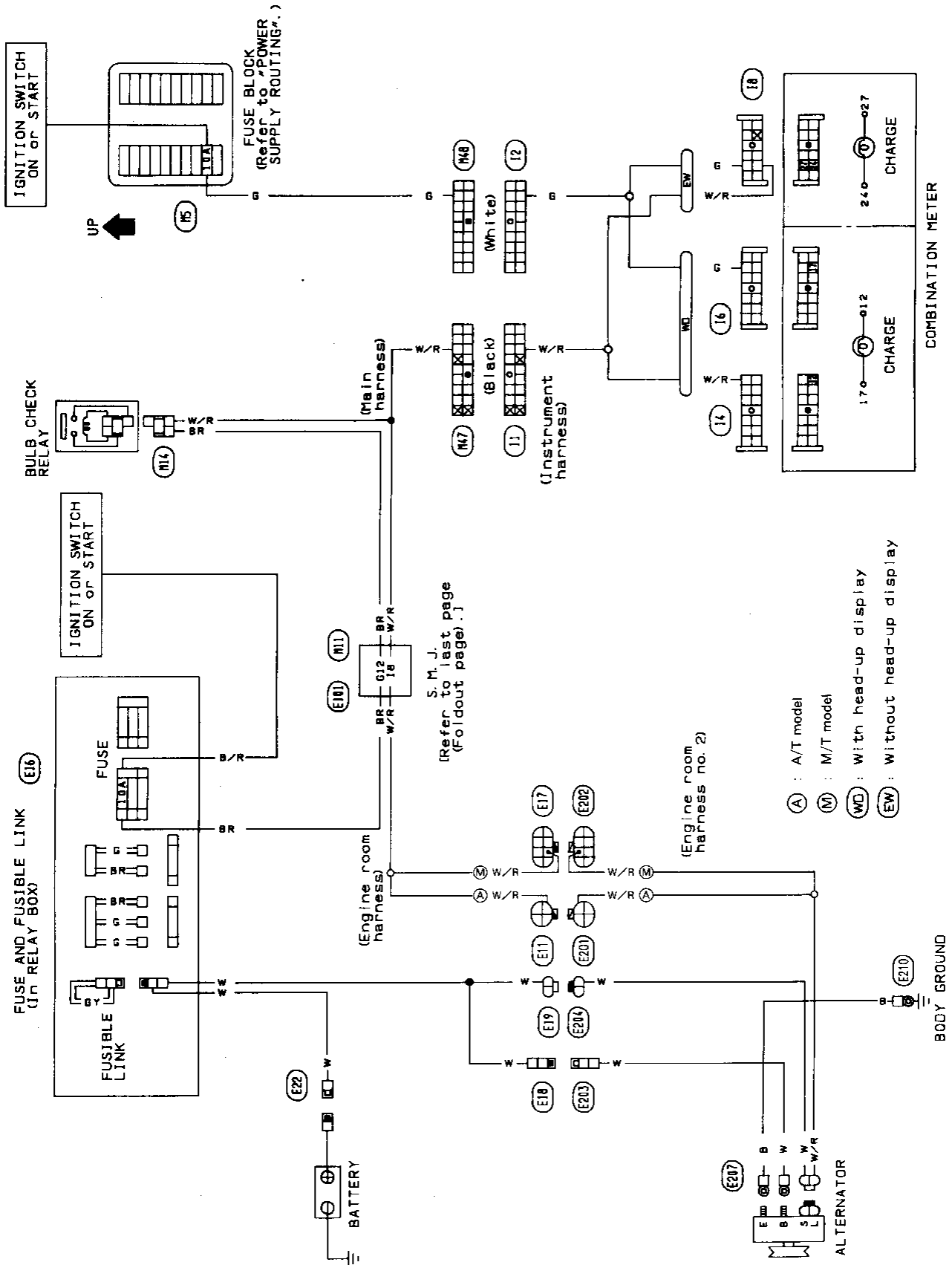

# CHARGING SYSTEM

## Construction

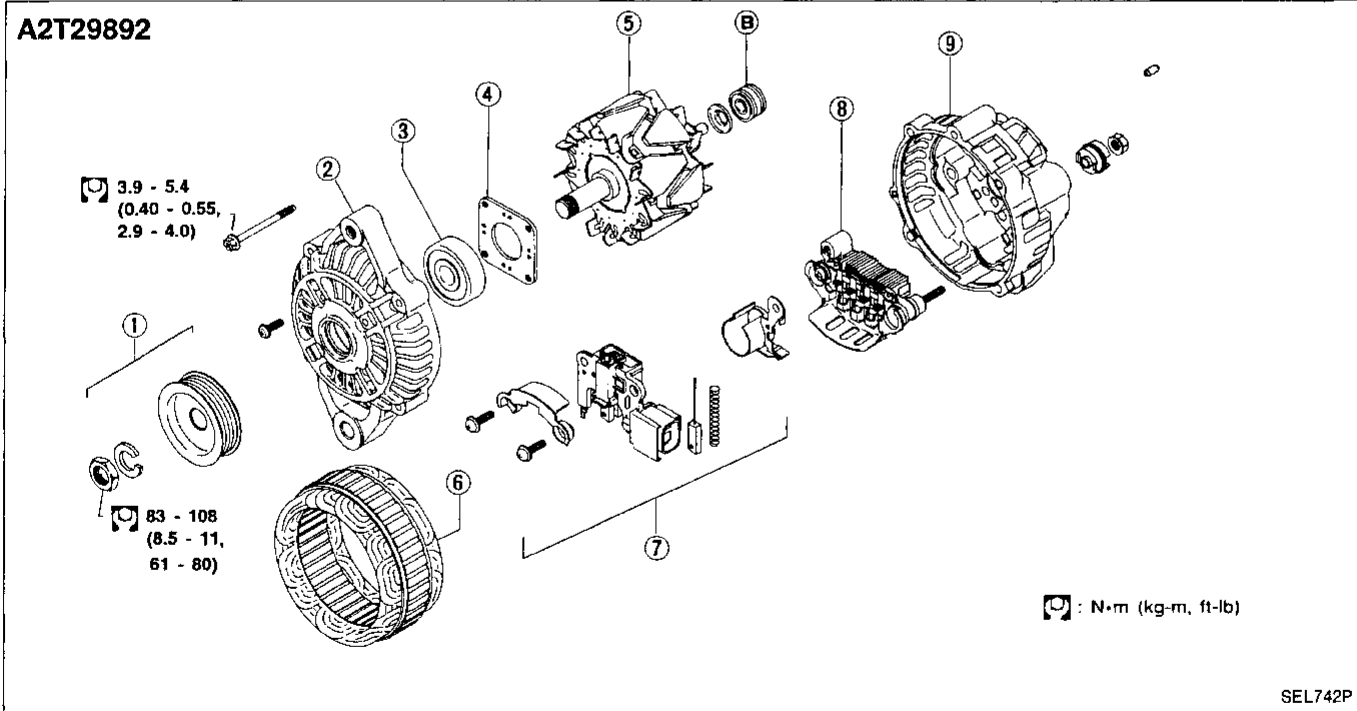
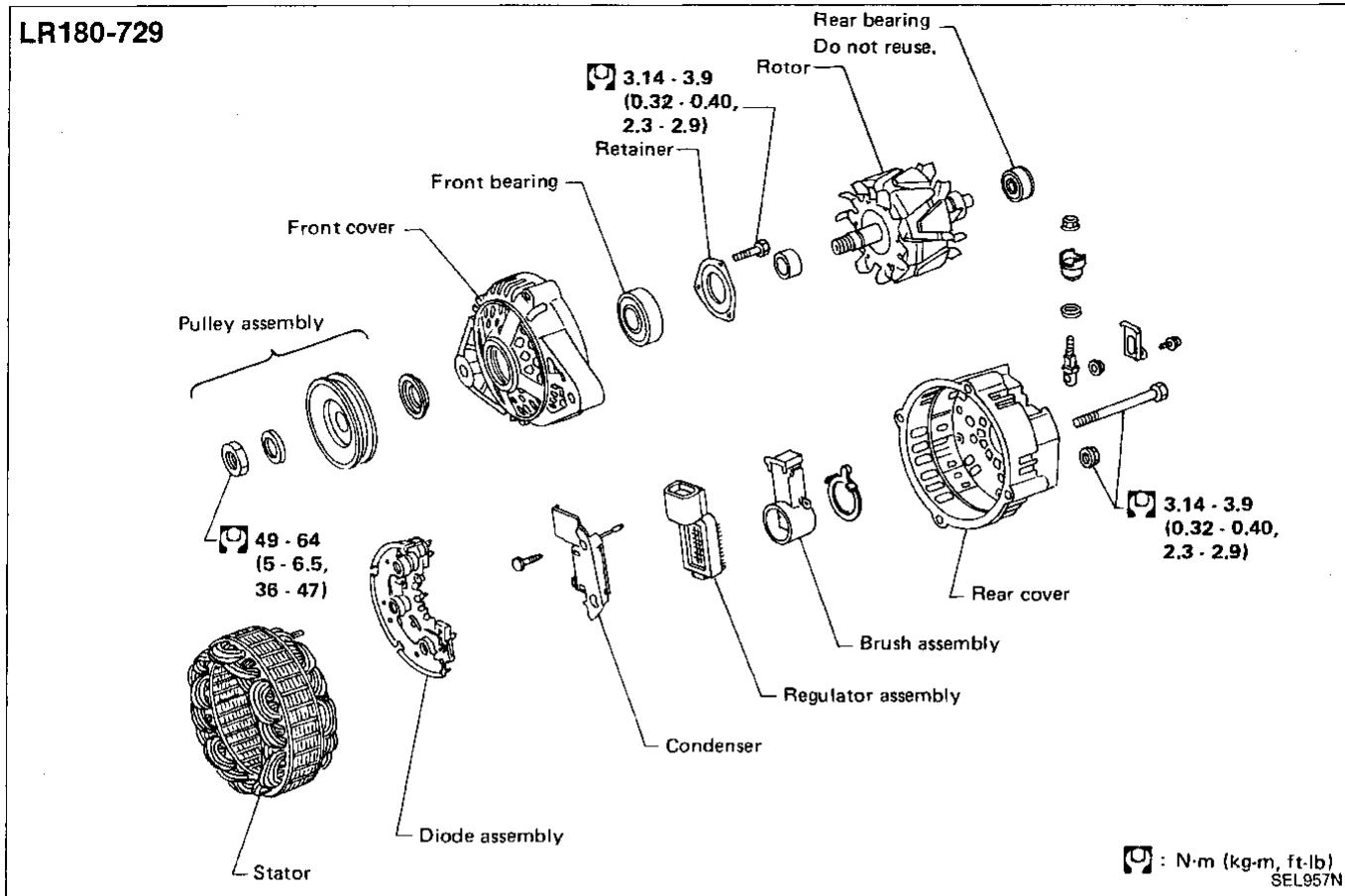

- ① Pulley assembly
- ② Front cover
- ③ Front bearing
- ④ Bearing retainer

- ⑤ Rotor
- ⑥ Stator
- ⑦ I.C. regulator
- ⑧ Diode assembly

- ⑨ Rear cover
- A Brush holder assembly
- B Rear bearing

# CHARGING SYSTEM

## Service Data and Specifications (S.D.S.)

### ALTERNATOR

Type		LR180-729	A2T29892
		HITACHI make	MITSUBISHI make
Nominal rating	V-A	12 - 80	
Ground polarity		Negative	
Minimum revolution under no-load (When 13.5 volts is applied)	rpm	Less than 950	1,100
Hot output current	A/rpm	More than 23/1,300 More than 63/2,500 More than 77/5,000	More than 21/1,300 More than 60/2,500
Regulated output voltage	V	14.1 - 14.7	
Minimum length of brush	mm (in)	6.0 (0.236)	8 (0.31)
Brush spring pressure	N (g, oz)	1.000 - 3.432 (102 - 350, 3.60 - 12.34)	3.138 - 4.315 (320 - 440, 11.29 - 15.52)
Slip ring minimum outer diameter	mm (in)	26.0 (1.024)	22.1 (0.870)



# COMBINATION SWITCH

## Combination Switch/Check

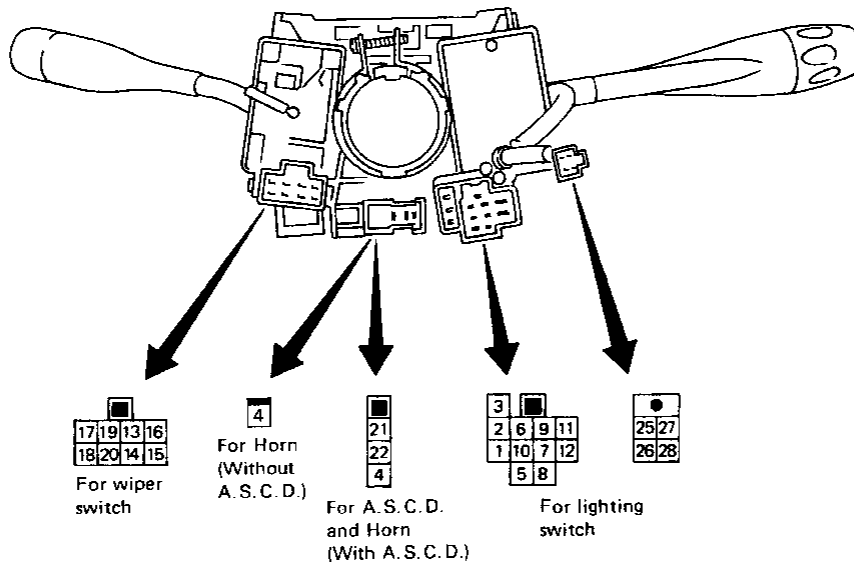
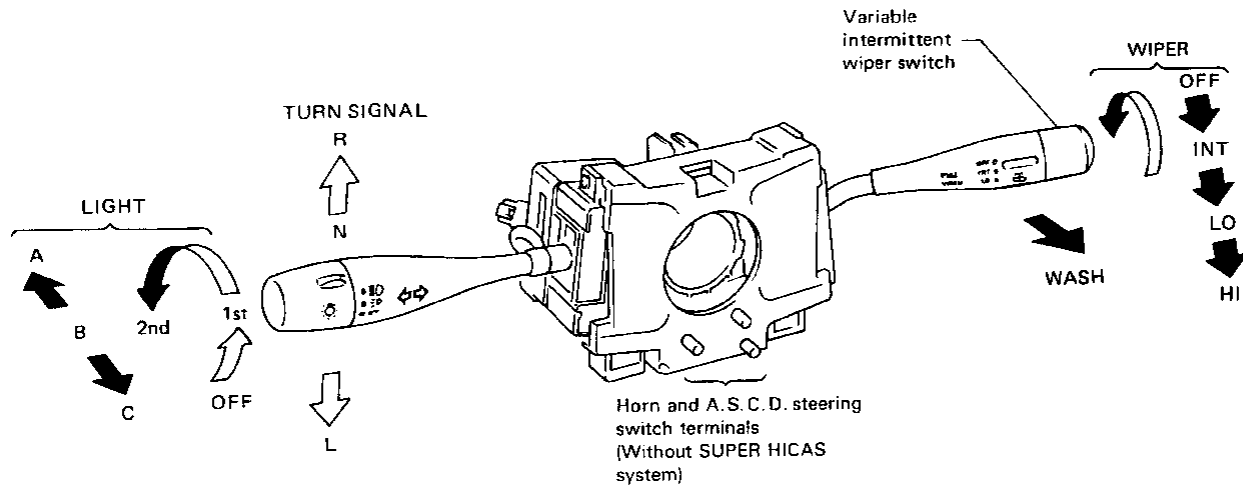

LIGHTING SWITCH

	OFF			1			2		
	A	B	C	A	B	C	A	B	C
5									
6									
7									
8									
9									
10									
11									
12									
25									
26									
27									
28									

WIPER SWITCH

	OFF	INT	LO	HI	WASH
13					
14					
15					
16					
17					
18					

INTERMITTENT WIPER VOLUME

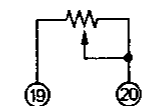

A.S.C.D. STEERING SWITCH

	RESUME ACCEL	N	SET COAST	OFF	CANCEL
4					
22					
21					

HORN SWITCH

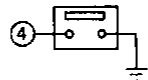

TURN SIGNAL SWITCH

	R	N	L
1			
2			
3			

GI  
MA  
EM  
LC  
EF & EC  
FE  
CL  
MT  
AT  
PD  
FA  
RA  
BR  
ST  
BF  
HA

EL

## COMBINATION SWITCH

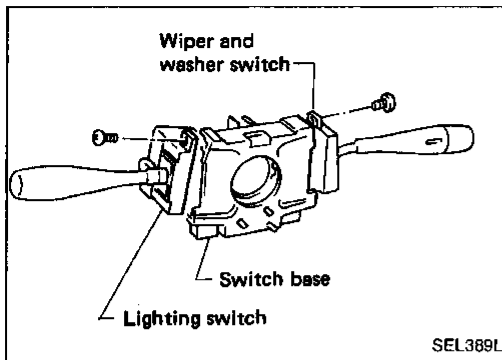

### Replacement

- Each switch can be replaced without removing combination switch base.

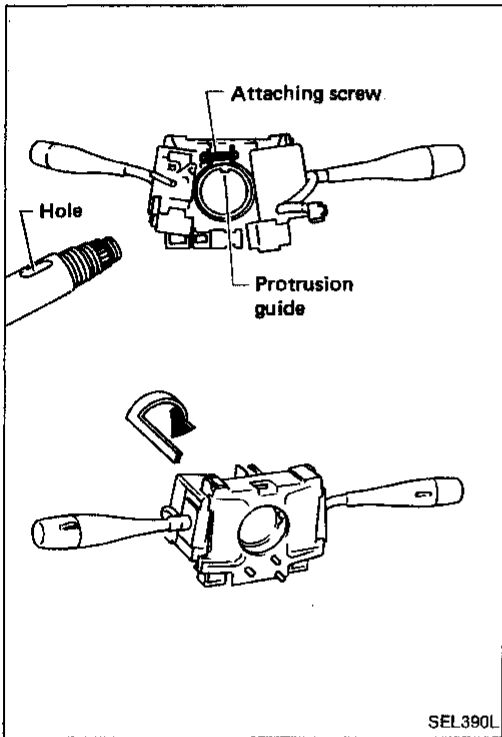

- To remove combination switch base, remove base attaching screw and turn after pushing on it.

# COMBINATION SWITCH

## Steering Switch/Check

WITH SUPER HICAS SYSTEM

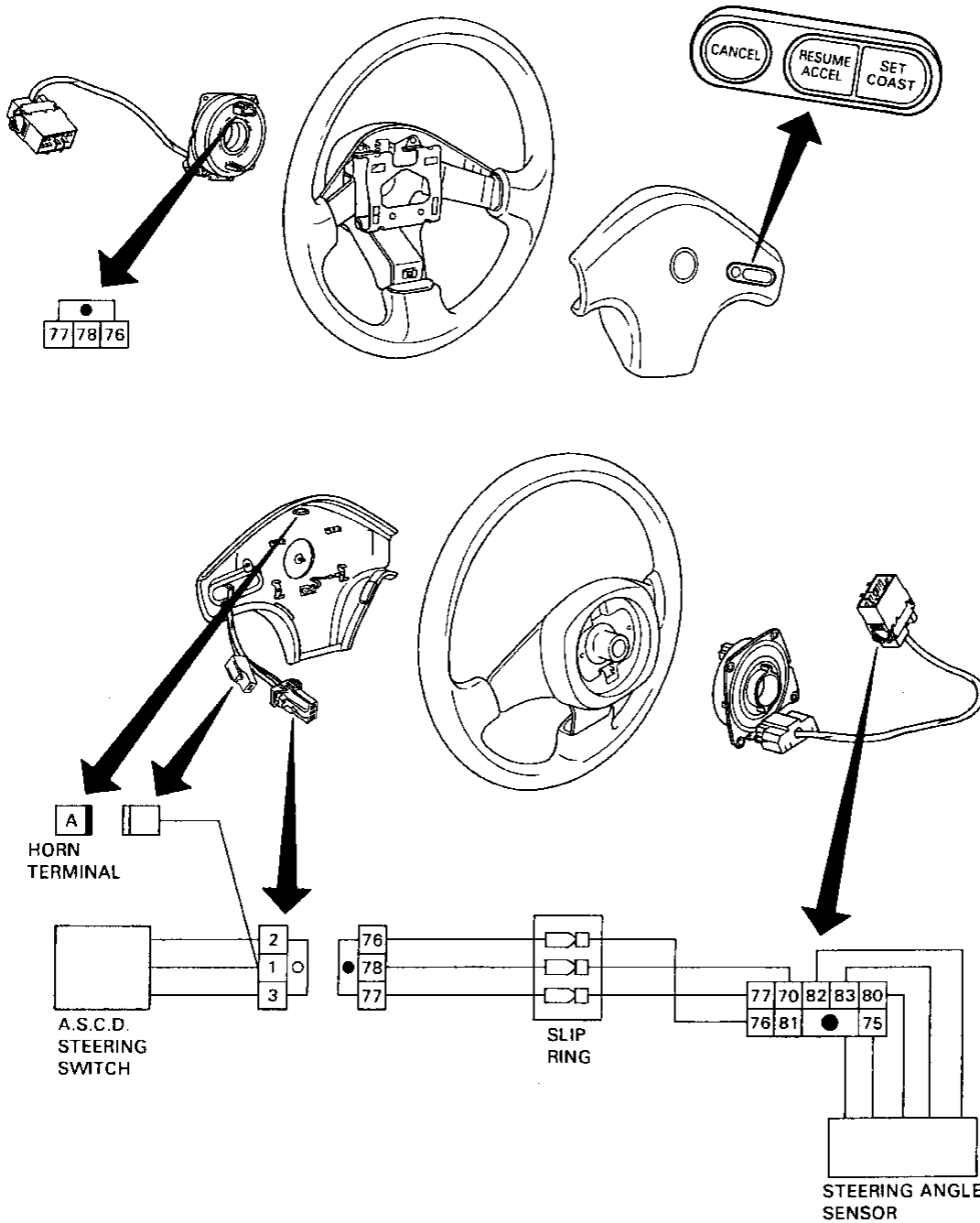

A.S.C.D. STEERING SWITCH

	RESUME ACCEL	N	SET COAST	OFF	CANCEL
1	○		○		○
2	○		○		○
3	○				○

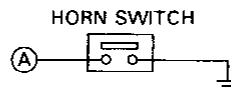

GI  
MA  
EM  
LC  
EF &  
EC  
FE  
CL  
MT  
AT  
PD  
FA  
RA  
BR  
ST  
BF  
HA

EL

# HEADLAMP

## Schematic

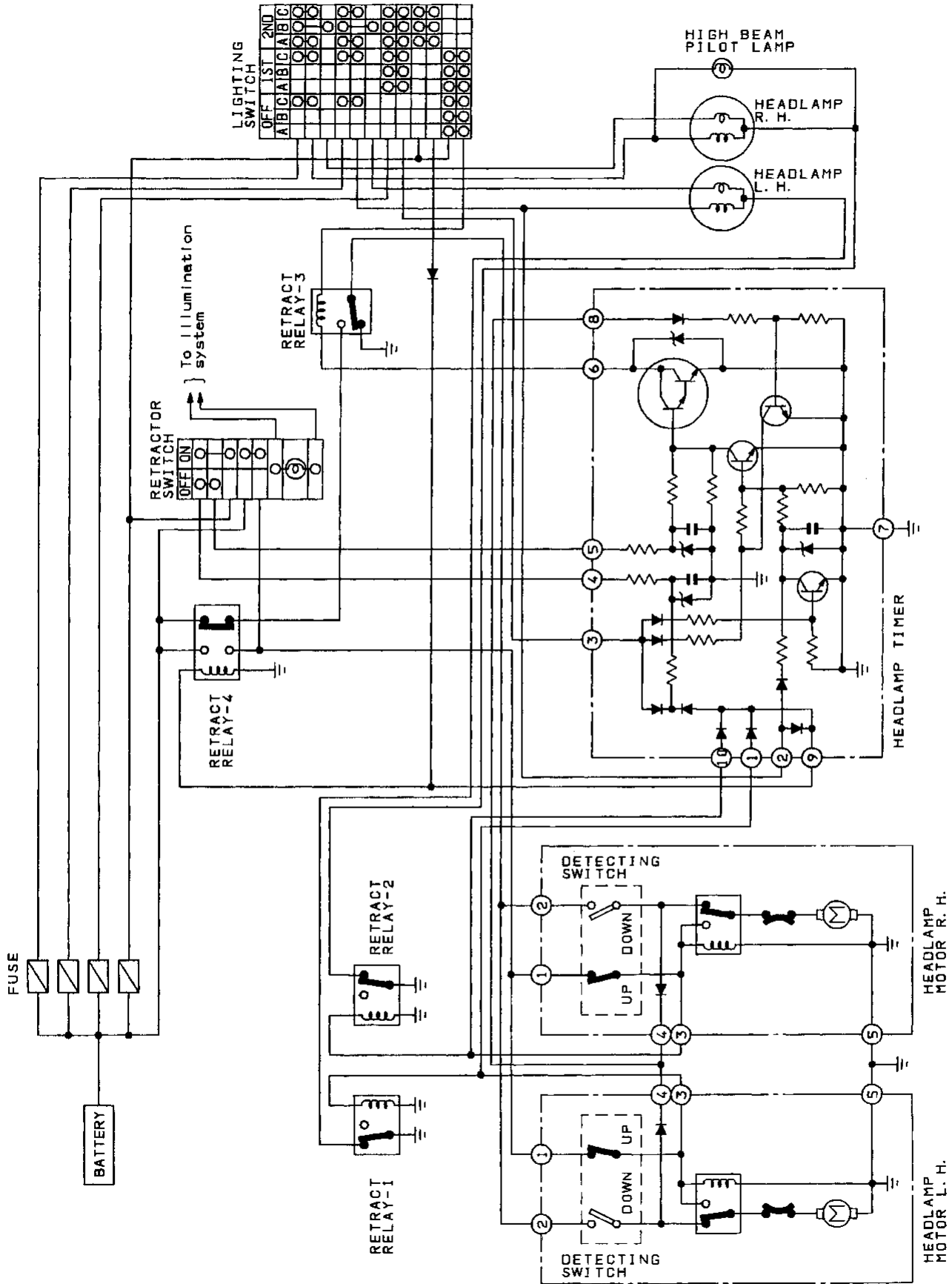

SEL469L

# HEADLAMP

## Wiring Diagram

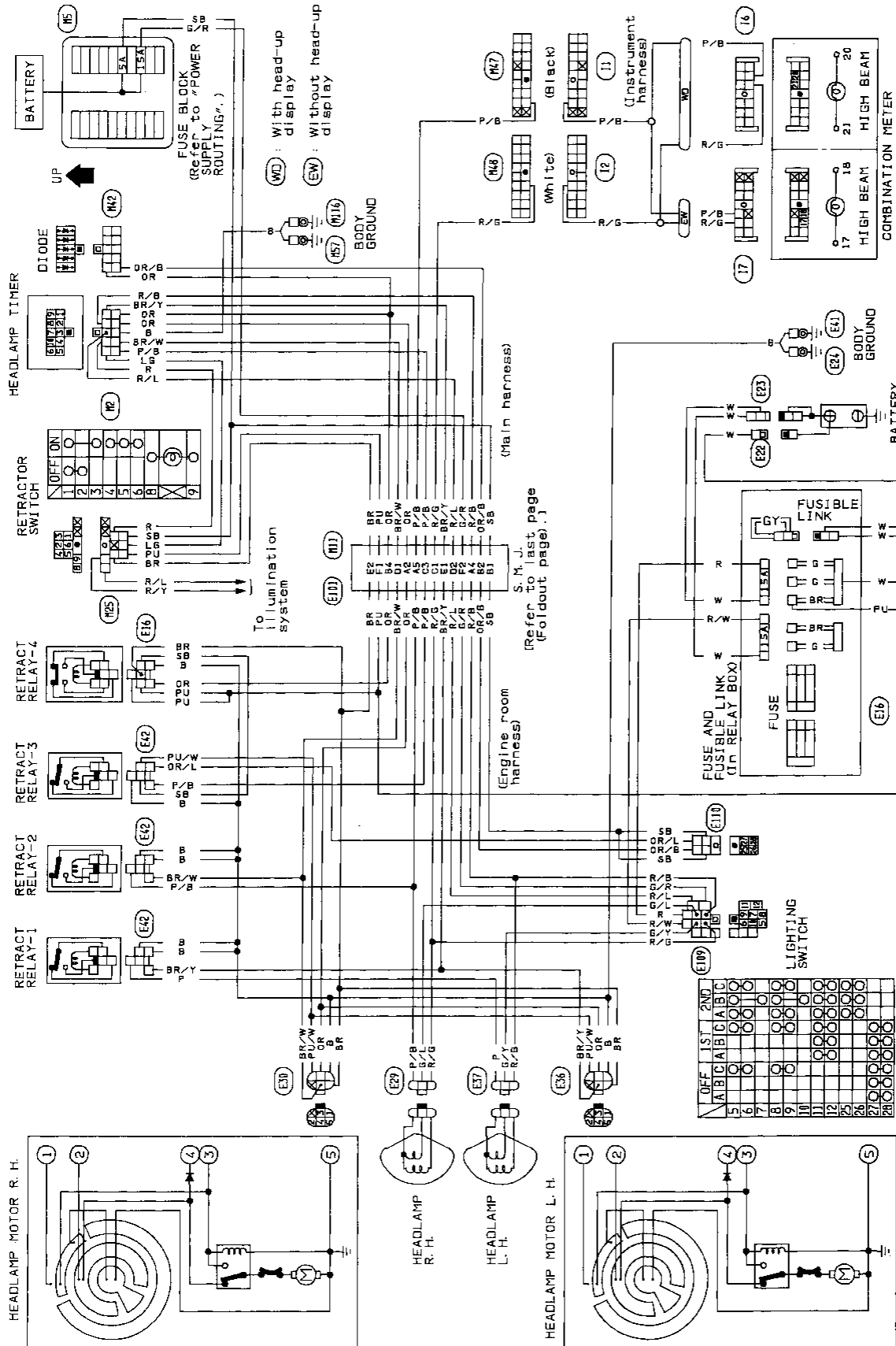

GI  
MA  
EM  
LC  
EF &  
EC  
FE  
CL  
MT  
AT  
PD  
FA  
RA  
BR  
ST  
BF  
HA

**EL**

# HEADLAMP

## Description

### BASIC OPERATION

Condition		Operation		
Lighting switch	Retractor switch	C/O*	Headlamp motor	Headlamps
OFF → 1ST	OFF		No operation	OFF
1ST → 2ND	OFF	[A]	Open	ON after headlamp motor reaches fully open position.
2ND → 1ST	OFF		Held to open position	OFF
1ST → OFF	OFF	[B]	Closed	OFF
Momentarily turned to PASSING	OFF	[C]	Opened and closed after headlamps go off.	Momentarily ON after headlamp motor reaches fully open position, and go off.
OFF	ON	[D]	Open	OFF

\*: Refer to CIRCUIT OPERATION.

# HEADLAMP

## Description (Cont'd)

### CIRCUIT OPERATION

[A] When lighting switch is switched from "1ST" → "2ND"

A-1: While operating the headlamp motor to open position

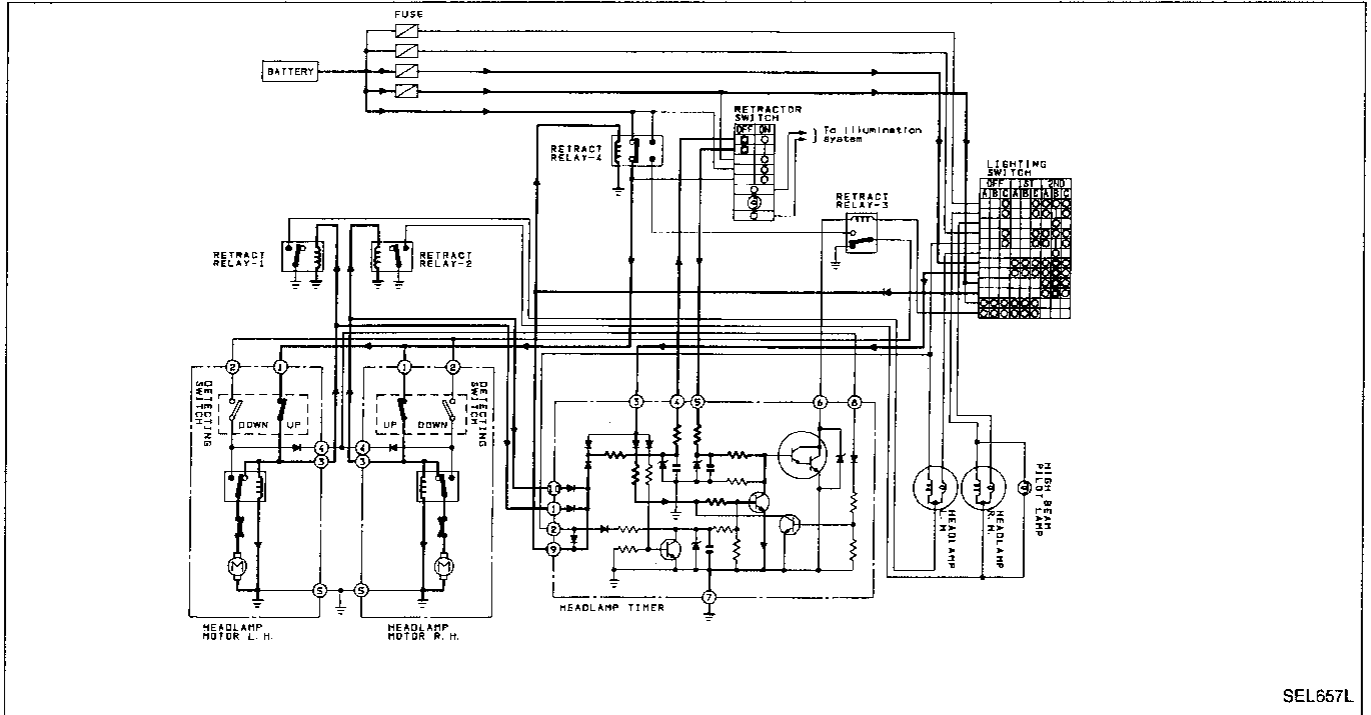

A-2: After the headlamp motor reaches fully open position

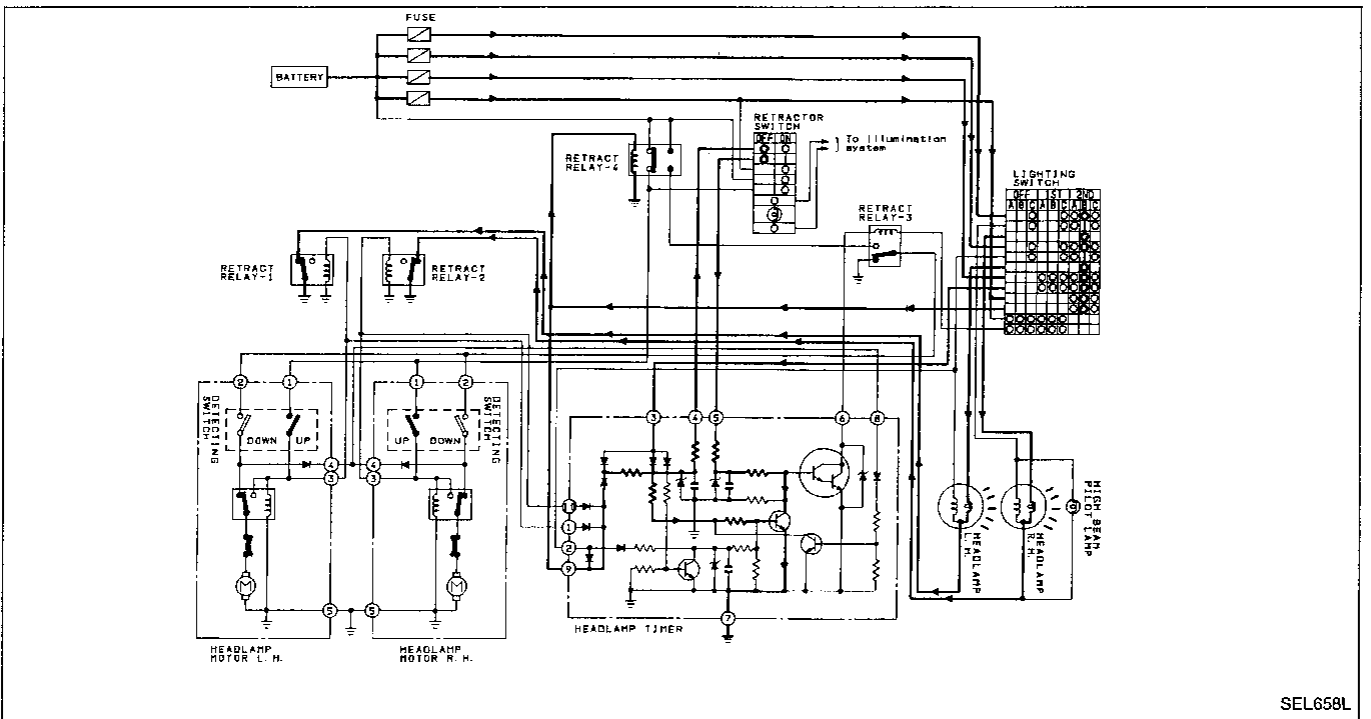

GI  
MA  
EM  
LC  
EF &  
EC  
FE  
CL  
MT  
AT  
PD  
FA  
RA  
BR  
ST  
BF  
HA

EL

# HEADLAMP

## Description (Cont'd)

[B] When lighting switch is switched from "1ST" → "OFF"  
(While operating the headlamp motor to closed position)

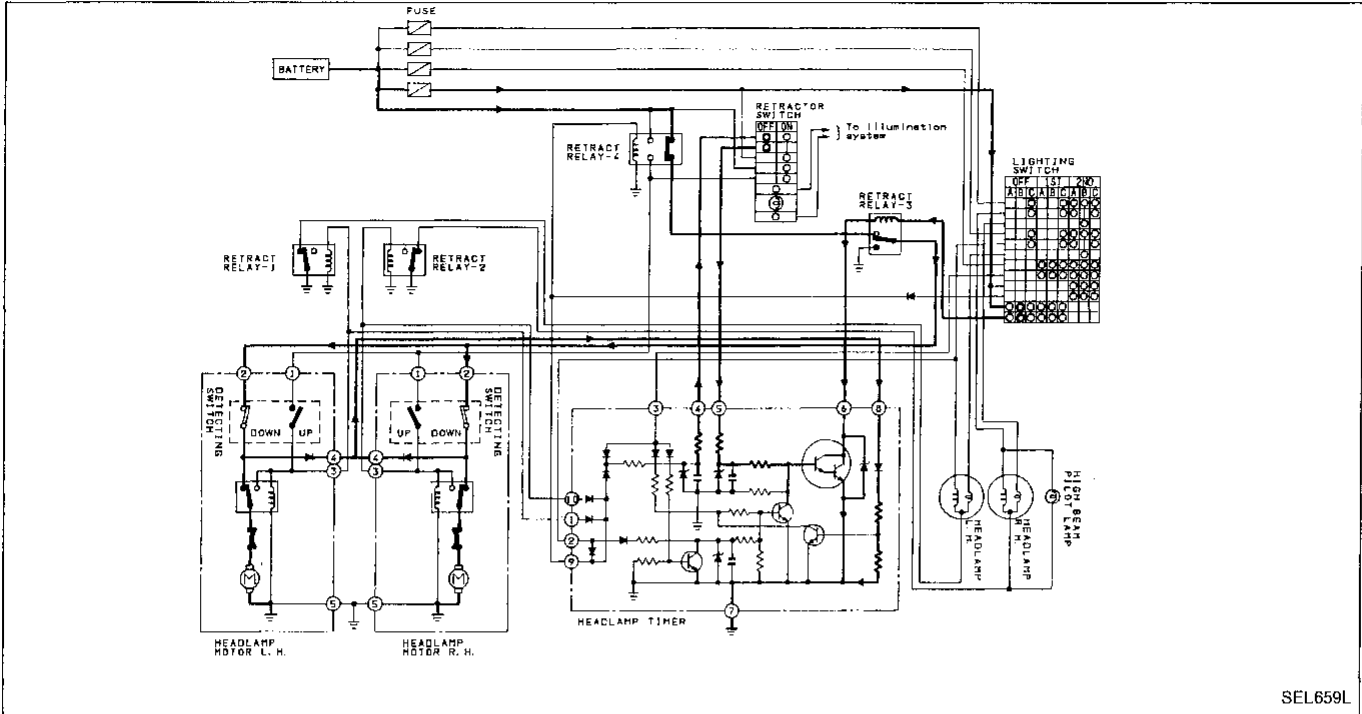

[C] When lighting switch is switched to "PASSING"  
C-1: While operating the headlamp motor to open position

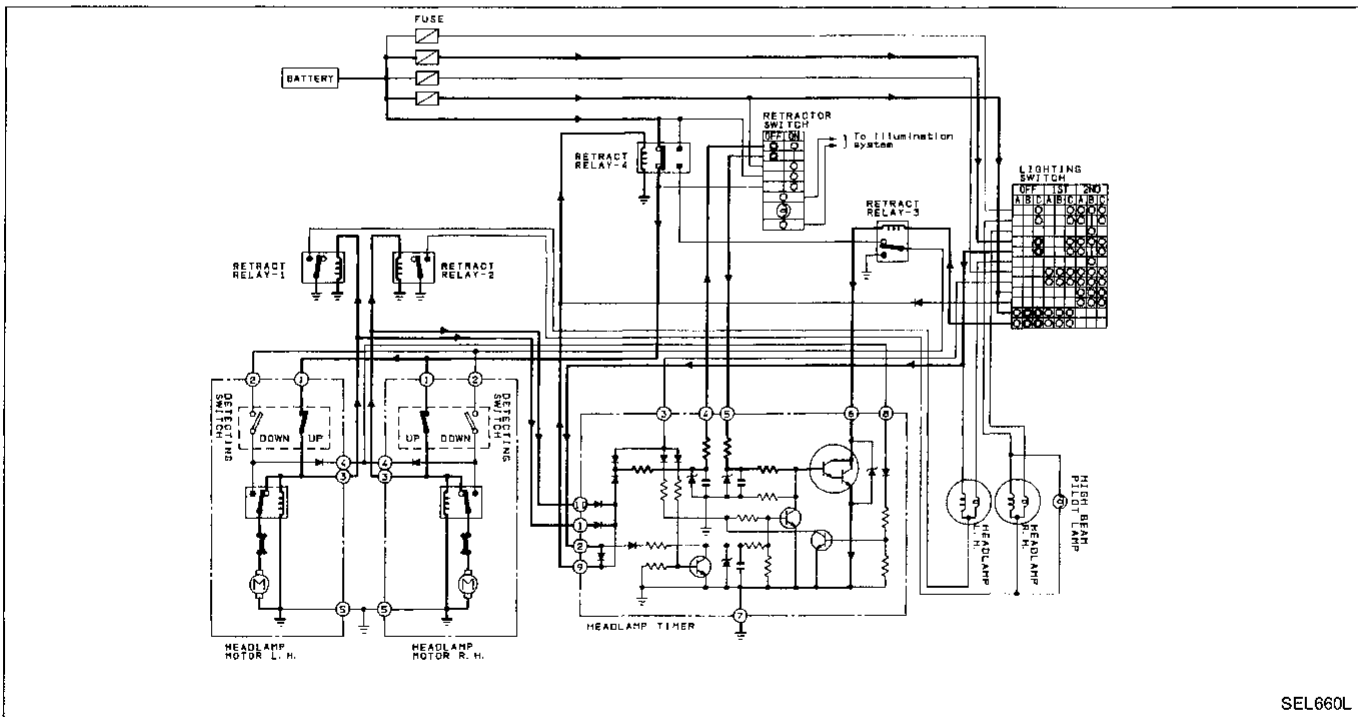



# HEADLAMP

## Description (Cont'd)

C-2: After the headlamp reaches fully open position

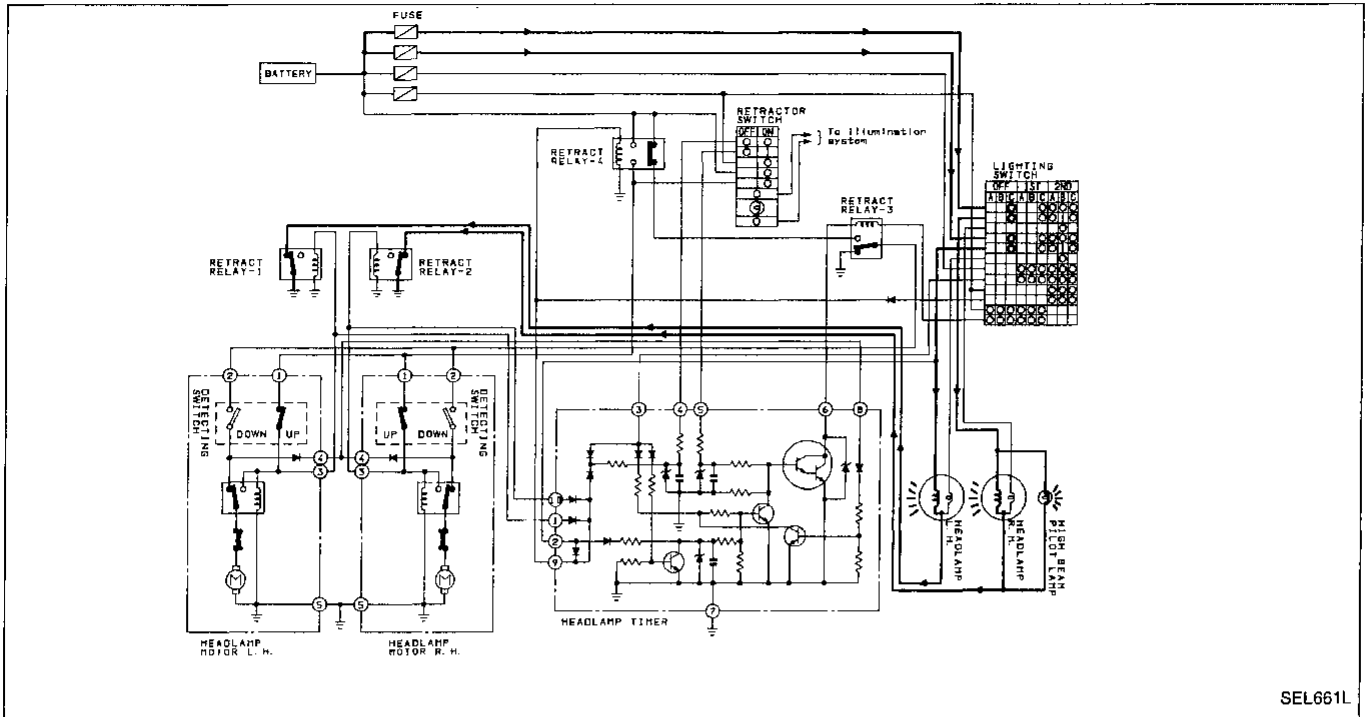

SEL661L

[D] When retractor switch is turned ON  
(While operating the headlamp motor to open position)

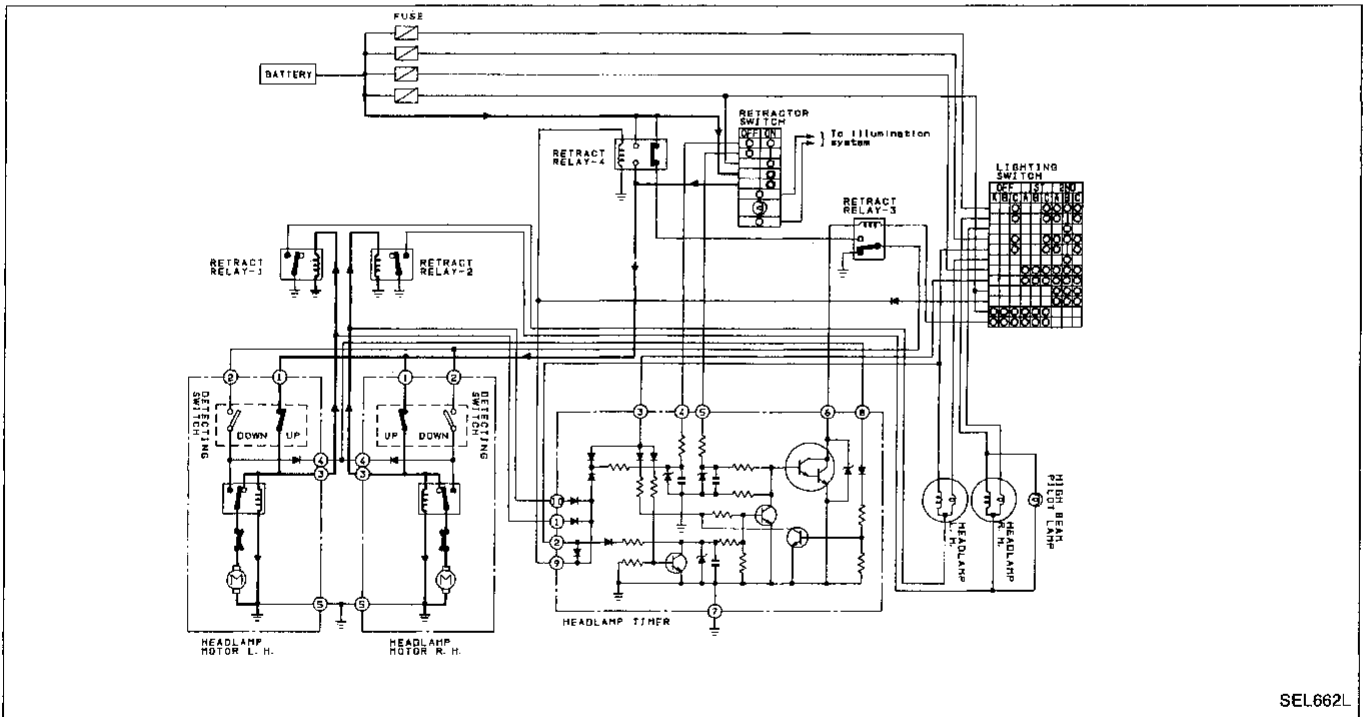

SEL662L

GI

MA

EM

LC

EF &  
EC

FE

CL

MT

AT

PD

FA

RA

BR

ST

BF

HA

EL

# HEADLAMP

## Constructions

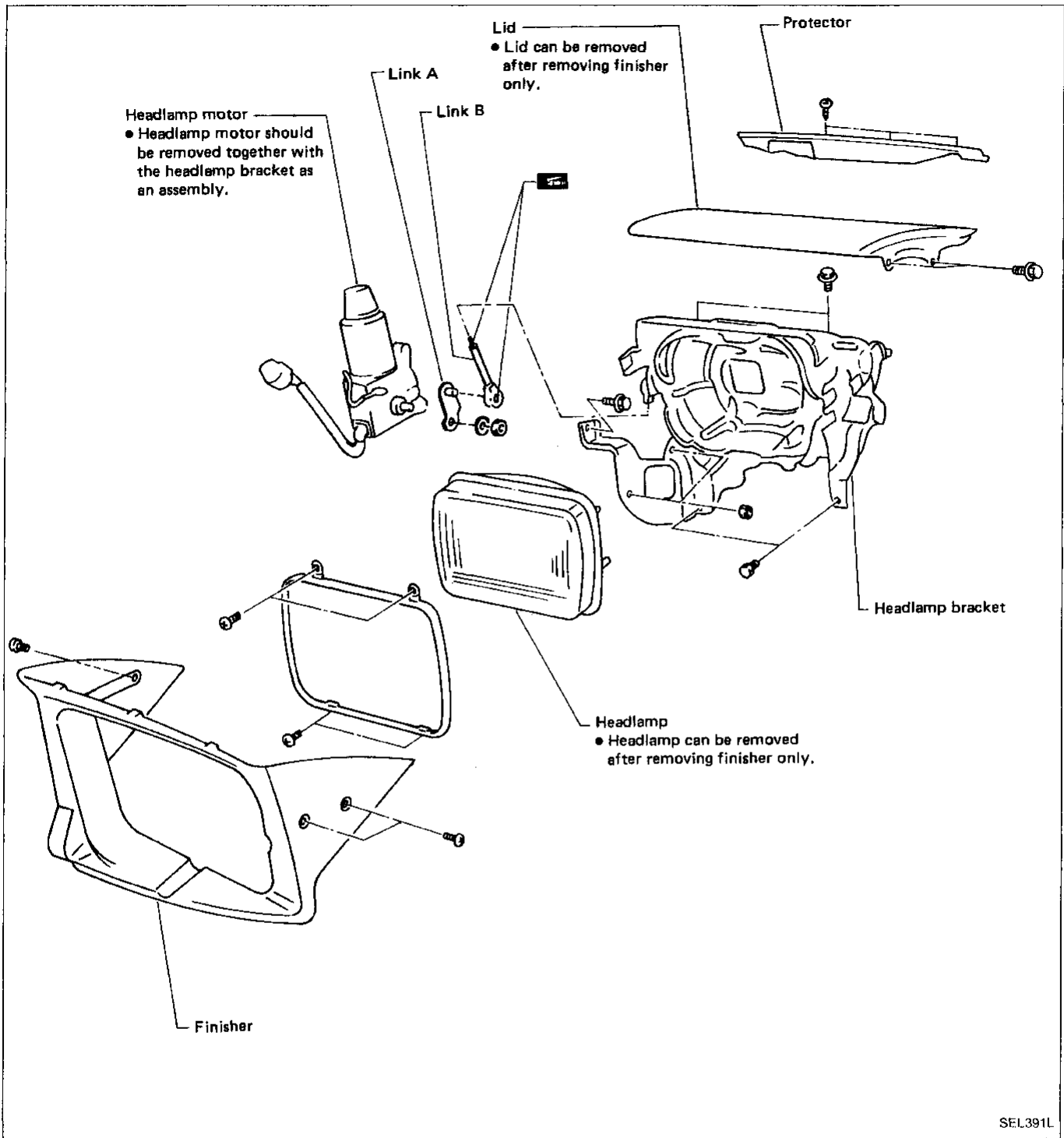

SEL391L

# HEADLAMP

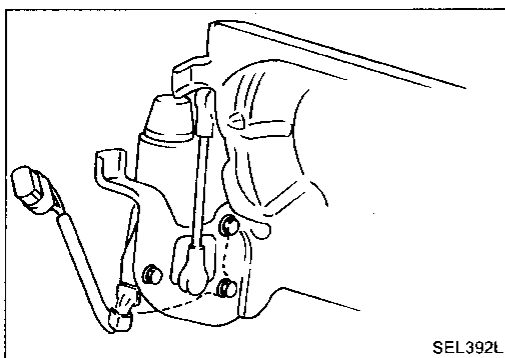

## Assembly

1. Install headlamp motor, ball joint and link A (as one unit) on headlamp bracket.
2. While turning link B, install link A's ball joint on headlamp housing's ball joint.
3. Set distance between centers of upper and lower ball joints as shown in figure at left, and tighten lock nuts.
4. Assemble headlamp, finisher and lid.

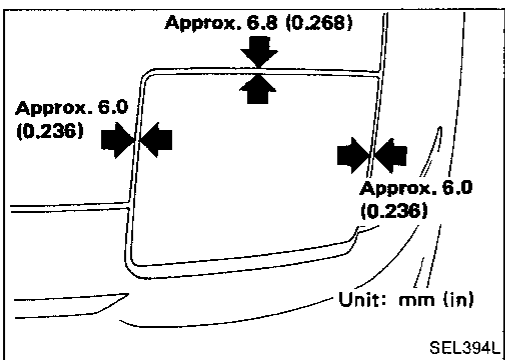
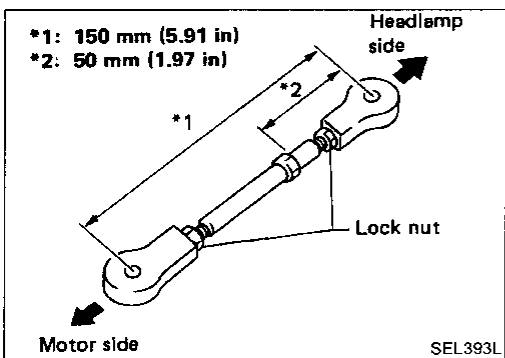

## Installation and Adjustment

Before doing this, be sure to disconnect battery ground cable.

1. Install headlamp bracket to body temporarily.
  - 1) Determine headlamp bracket location on body so that alignment between lid, hood, and fender looks straight.
  - 2) After adjusting alignment, tighten headlamp bracket to body.

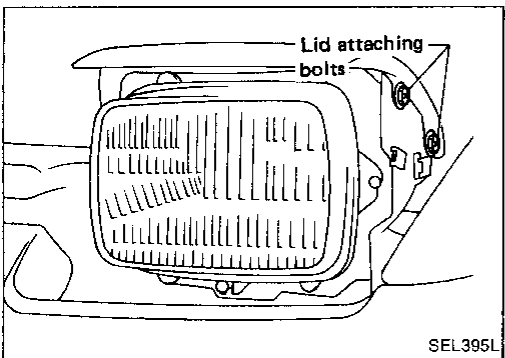

2. Adjust lid alignment.
  - Adjust lid, hood and fender for alignment while opening and closing headlamp with motor manual knob.

**Use motor manual knob to open and close headlamp, and adjust alignment while checking that lid is not interfering with hood.**

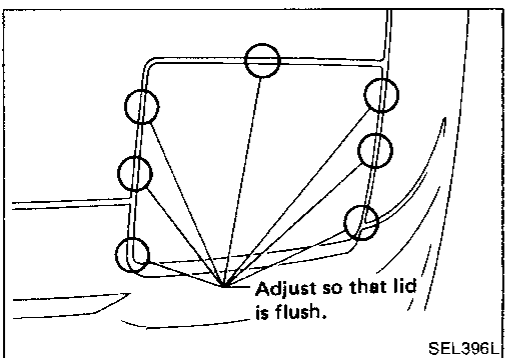

GI

MA

EM

LC

EF &  
EC

FE

CL

MT

AT

PD

FA

RA

BR

ST

BF

HA

EL

## HEADLAMP

### Installation and Adjustment (Cont'd)

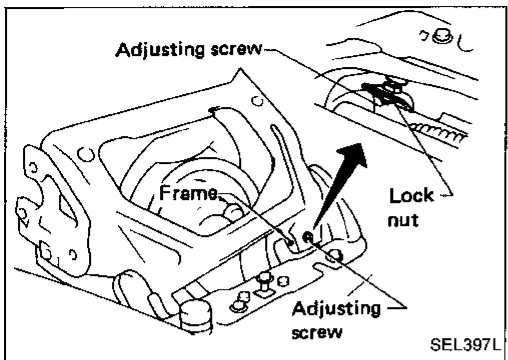

3. Adjust stopper.
- 1) Loosen lock nut on stopper.
- 2) Turn motor manual knob to open headlamp assembly completely.
- 3) Adjust stopper screw.

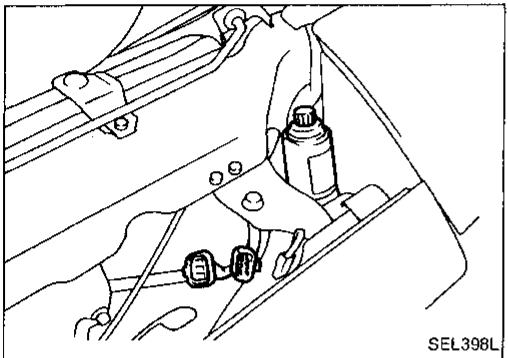

### Headlamp Motor Check

1. Disconnect battery ground cable.
2. Disconnect the headlamp motor connector.
3. Use an ohmmeter to check for continuity in headlamp motor circuit while rotating motor with manual knob.

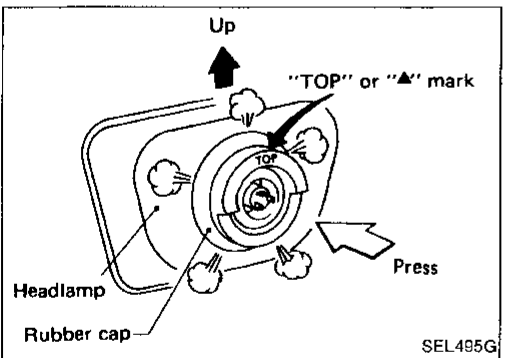
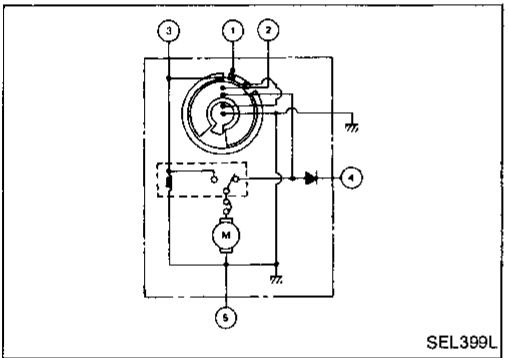

### INSTALLING HEADLAMP RUBBER CAP

When installing the rubber cap, set the "TOP" or "▲" mark so that it is facing up.

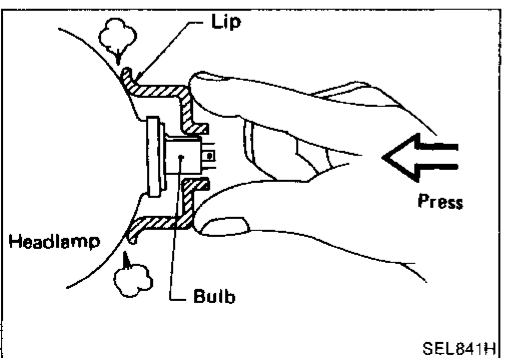

Press the rubber cap firmly so that the lip makes contact with the headlamp body.

# HEADLAMP

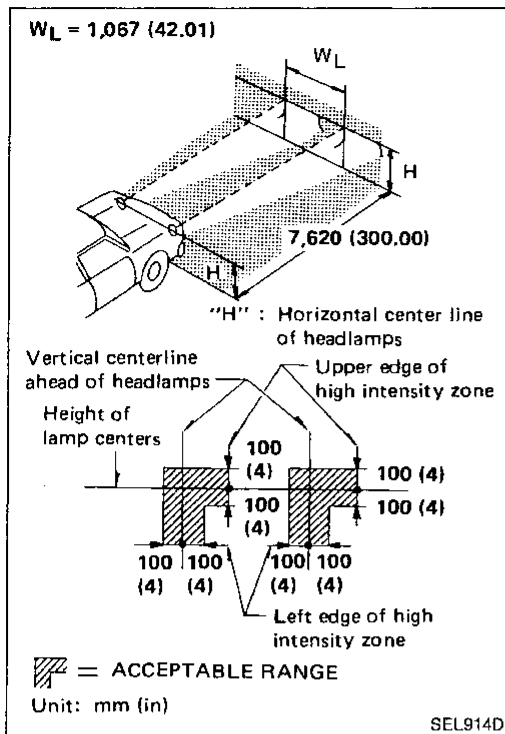

## Aiming Adjustment

When performing headlamp aiming adjustment, use an aiming machine, aiming wall screen or headlamp tester. For operating instructions of any aimer, it should be in good repair, calibrated and used according to respective operation manuals supplied with the unit.

If any aimer is not available, aiming adjustment can be done as follows:

**For details, refer to the regulations in your own country.**

### CAUTION:

- Keep all tires inflated to correct pressures.
  - Place vehicle and tester on one and same flat surface.
  - See that there is no-load in vehicle (coolant, engine oil filled up to correct level and full fuel tank) other than the driver (or equivalent weight placed in driver's position).
- Adjust headlamps so that upper edge and left edge of high intensity zone are within the acceptable range as shown.
  - Dotted lines in illustration show center of headlamp.

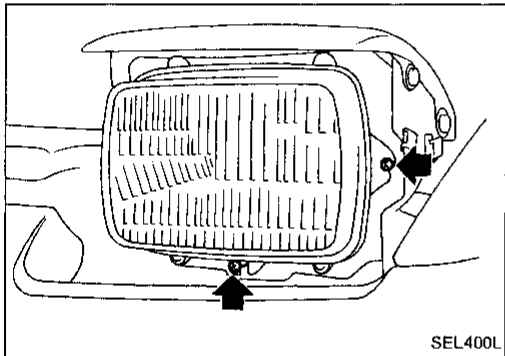

## ADJUSTING SCREWS

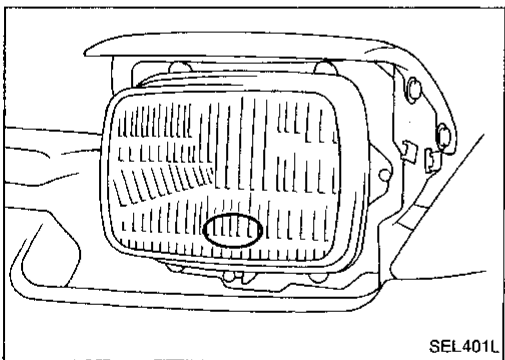

## AIMER ADJUSTMENT MARK

When using a mechanical aimer, adjust adapter legs to the data marked on the headlamps.

Example:

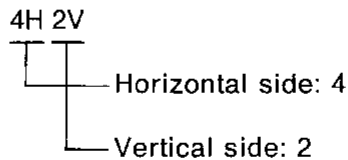

GI  
MA  
EM  
LC  
EF & EC  
FE  
CL  
MT  
AT  
PD  
FA  
RA  
BR  
ST  
BF  
HA

EL

# EXTERIOR LAMP

## Daytime Light/Description & Schematic

### OPERATION

After starting the engine with the lighting switch in the "OFF" or "1ST" position, the daytime light automatically turns on. With the lighting switch in the "2ND" position, the daytime light turns on while the headlamp motor is operating the headlamps to the open position and turns off after the headlamps reach the fully open position. Lighting switch operations other than the above are the same as in conventional systems.

Engine		With engine stopped									With engine running								
Lighting switch		OFF			1ST			2ND			OFF			1ST			2ND		
		A	B	C	A	B	C	A	B	C	A	B	C	A	B	C	A	B	C
Headlamp	High beam	X	X	○	X	X	○	○	X	○	X	X	○	X	X	○	○	X	○
	Low beam	X	X	X	X	X	X	X	○	X	X	X	X	X	X	X	X	○	X
Clearance and tail lamp		X	X	X	○	○	○	○	○	○	X	X	X	○	○	○	○	○	○
License and instrument illumination lamp		X	X	X	○	○	○	○	○	○	X	X	X	○	○	○	○	○	○
Daytime light		X	X	X	X	X	X	X	X	X	○*	○*	○*	○	○	○	X	X	X

○ : Lamp "ON"

X : Lamp "OFF"

\* : When starting the engine with the parking brake released, the Daytime lamp will come ON.  
 When starting the engine with the parking brake pulled, the Daytime lamp won't come ON.

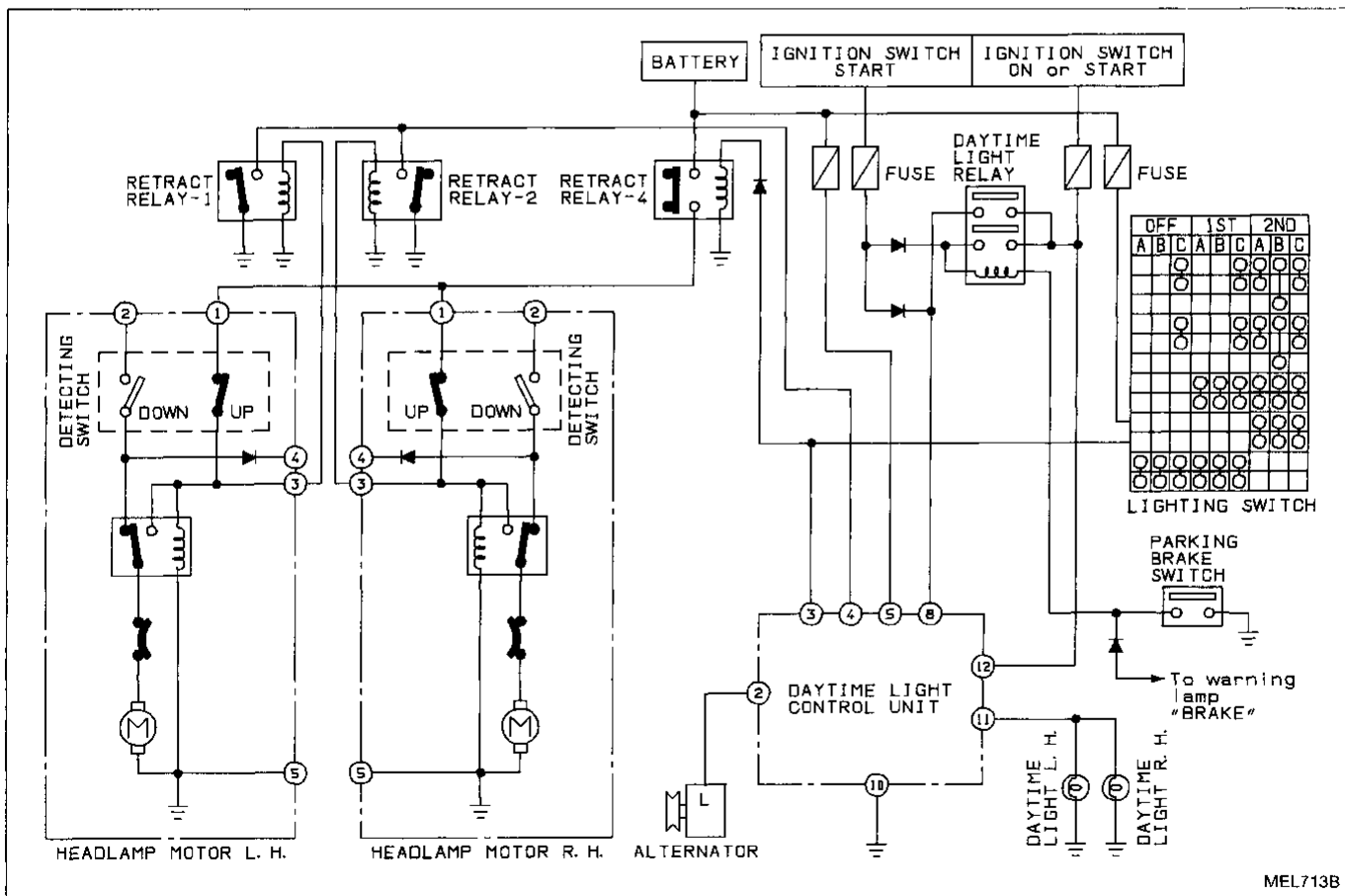

MEL713B

# EXTERIOR LAMP

## Daytime Light/Wiring Diagram

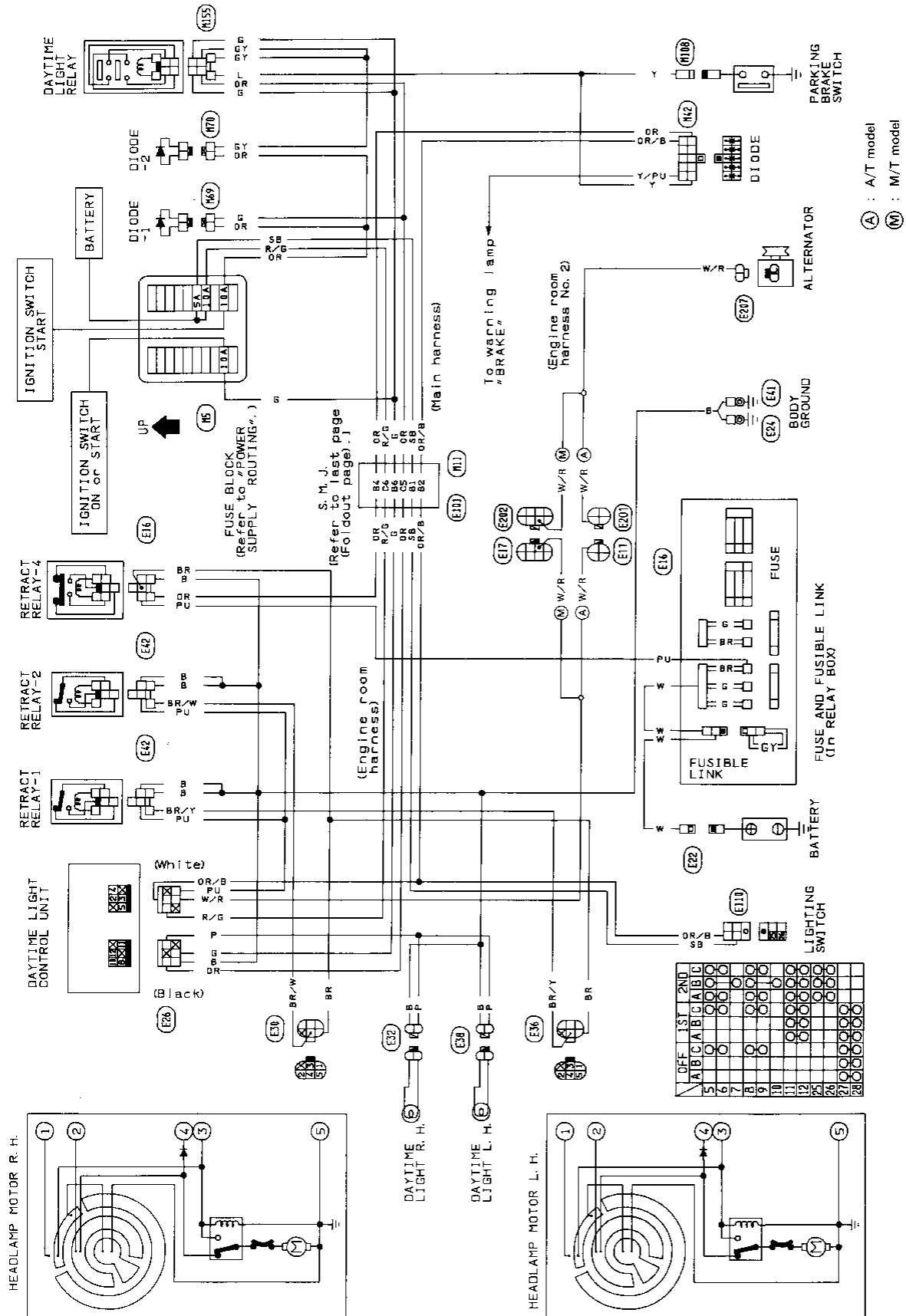

GI  
 MA  
 EM  
 LC  
 EF &  
 EC  
 FE  
 CL  
 MT  
 AT  
 PD  
 FA  
 RA  
 BR  
 ST  
 BF  
 HA  
**EL**

EXTERIOR LAMP

Clearance, License, Tail and Stop Lamps/Wiring Diagram

FASTBACK

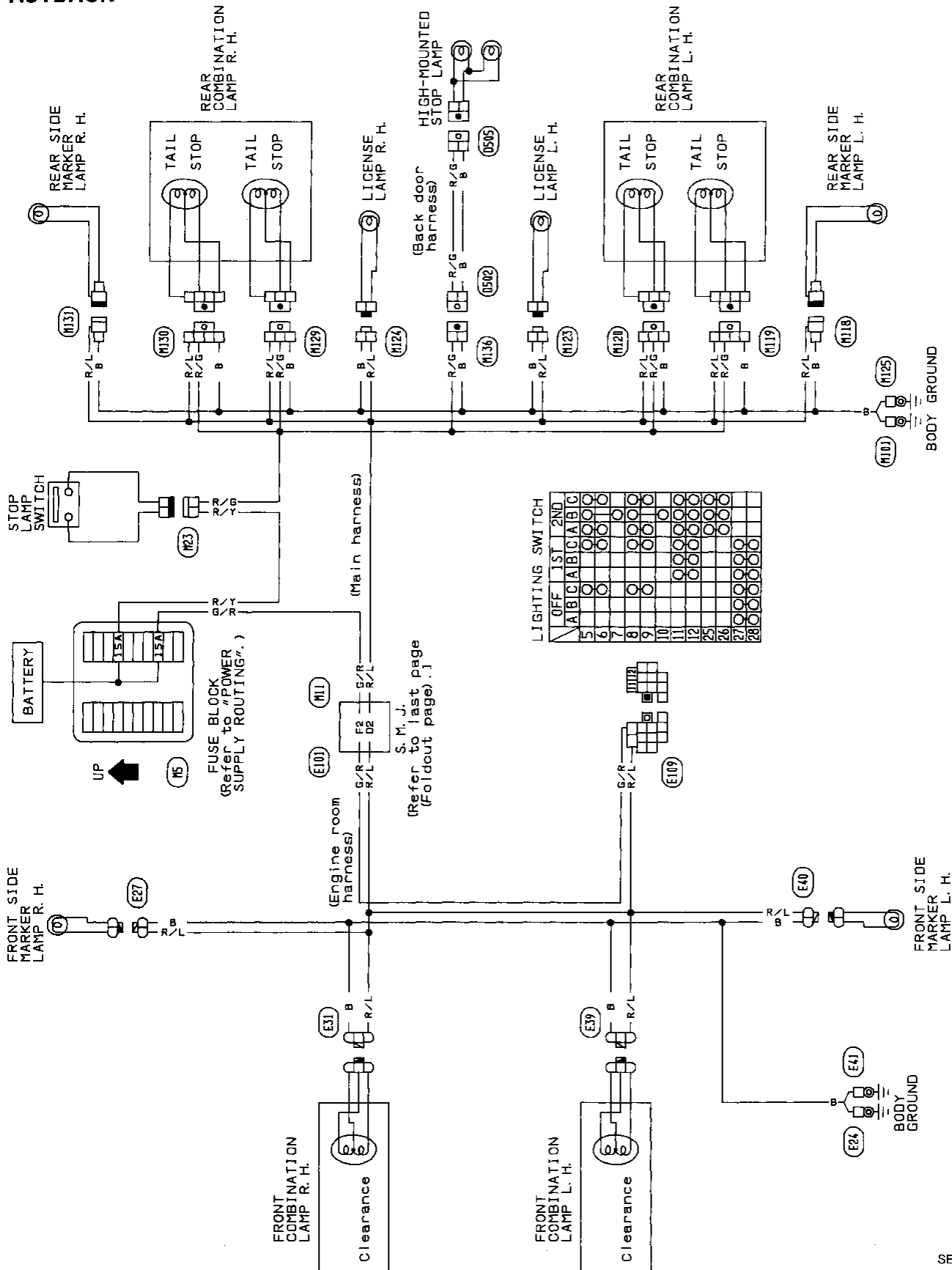



# EXTERIOR LAMP

## Clearance, License, Tail and Stop Lamps/Wiring Diagram (Cont'd)

COUPE

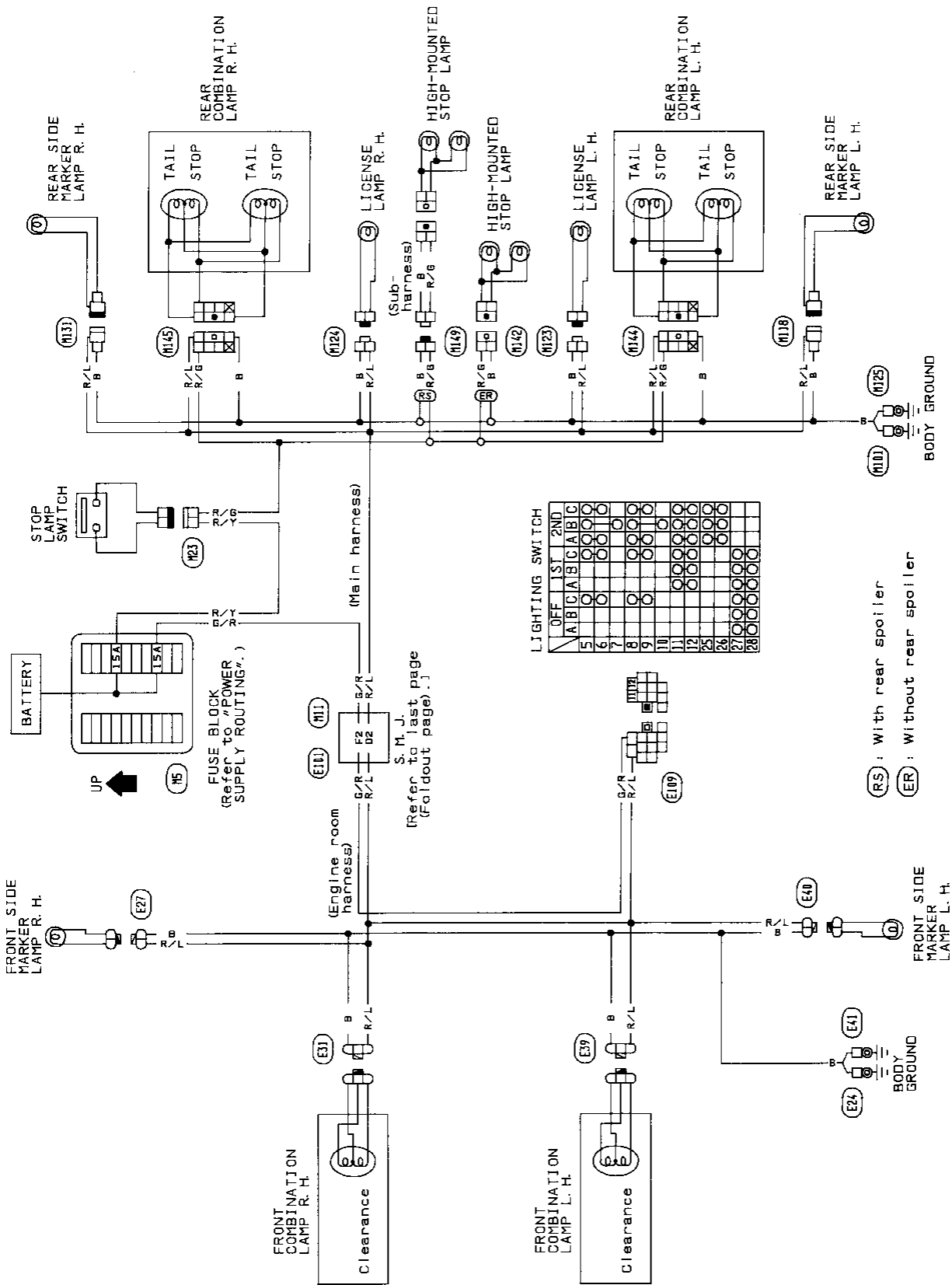

GI  
MA  
EM  
LC  
EF &  
EC  
FE  
CL  
MT  
AT  
PD  
FA  
RA  
BR  
ST  
BF  
HA  
EL

# EXTERIOR LAMP

## Back-up Lamp/Wiring Diagram

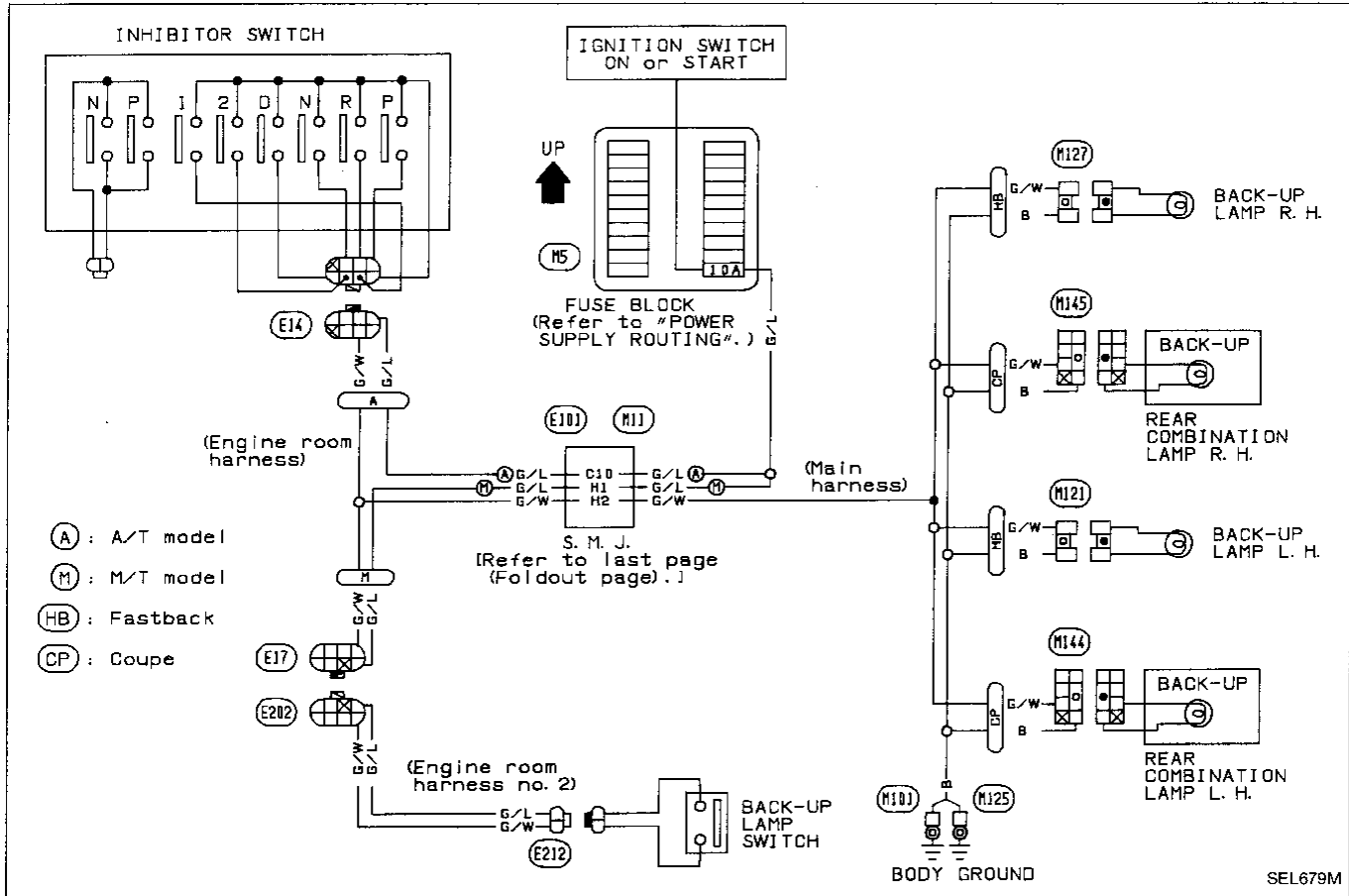

SEL679M

# EXTERIOR LAMP

## Turn Signal and Hazard Warning Lamps/Wiring Diagram

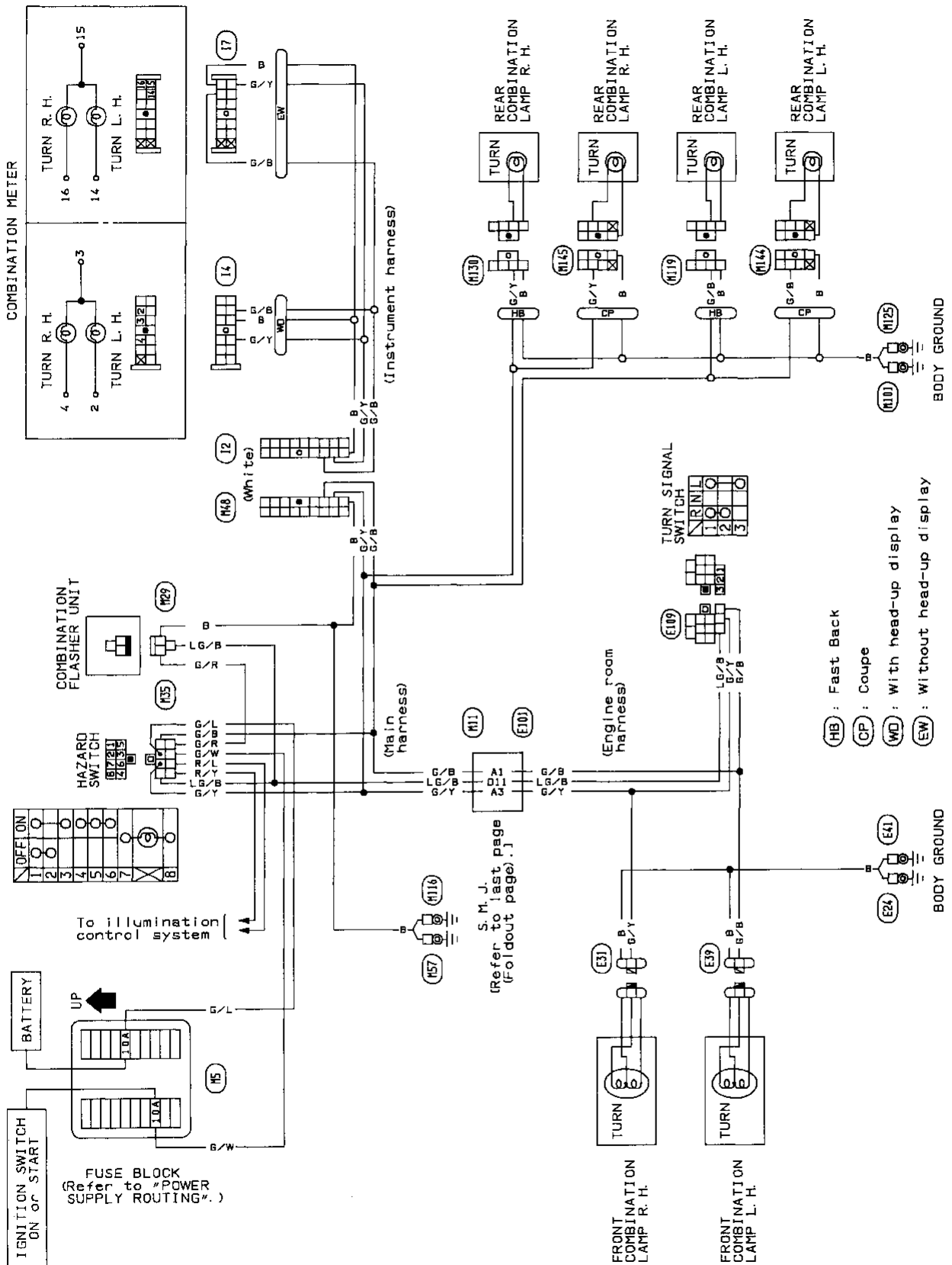

GI

MA

EM

LC

FF &

EC

FE

CL

MT

AT

PD

FA

RA

BR

ST

BF

HA

EL

## EXTERIOR LAMP

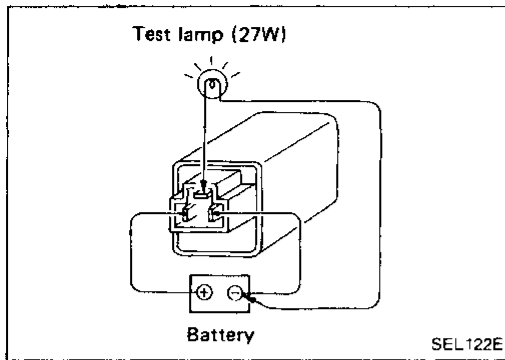

### Combination Flasher Unit Check

- Before checking, ensure that bulbs meet specifications.
- Connect a battery and test lamp to the combination flasher unit, as shown. Combination flasher unit is properly functioning if it blinks when power is supplied to the circuit.

### Bulb Specifications

Item	Wattage (W)
Headlamp (Sealed)	65/35
Daytime light	27
Front combination lamp	
Front turn signal/Clearance	27/8
Front side marker lamp	3.8
Rear side marker lamp	3.8
Rear combination lamp	
Turn signal lamp	27
Stop/Tail lamp	27/8
Back-up lamp	27
License plate lamp	7.5
Interior lamp	10
Spot lamp	8
Trunk room lamp (Coupe)	3.4
Foot well lamp	3
Luggage compartment lamp (Fastback)	5
High-mounted stop lamp	18

# INTERIOR LAMP

## Illumination/Wiring Diagram

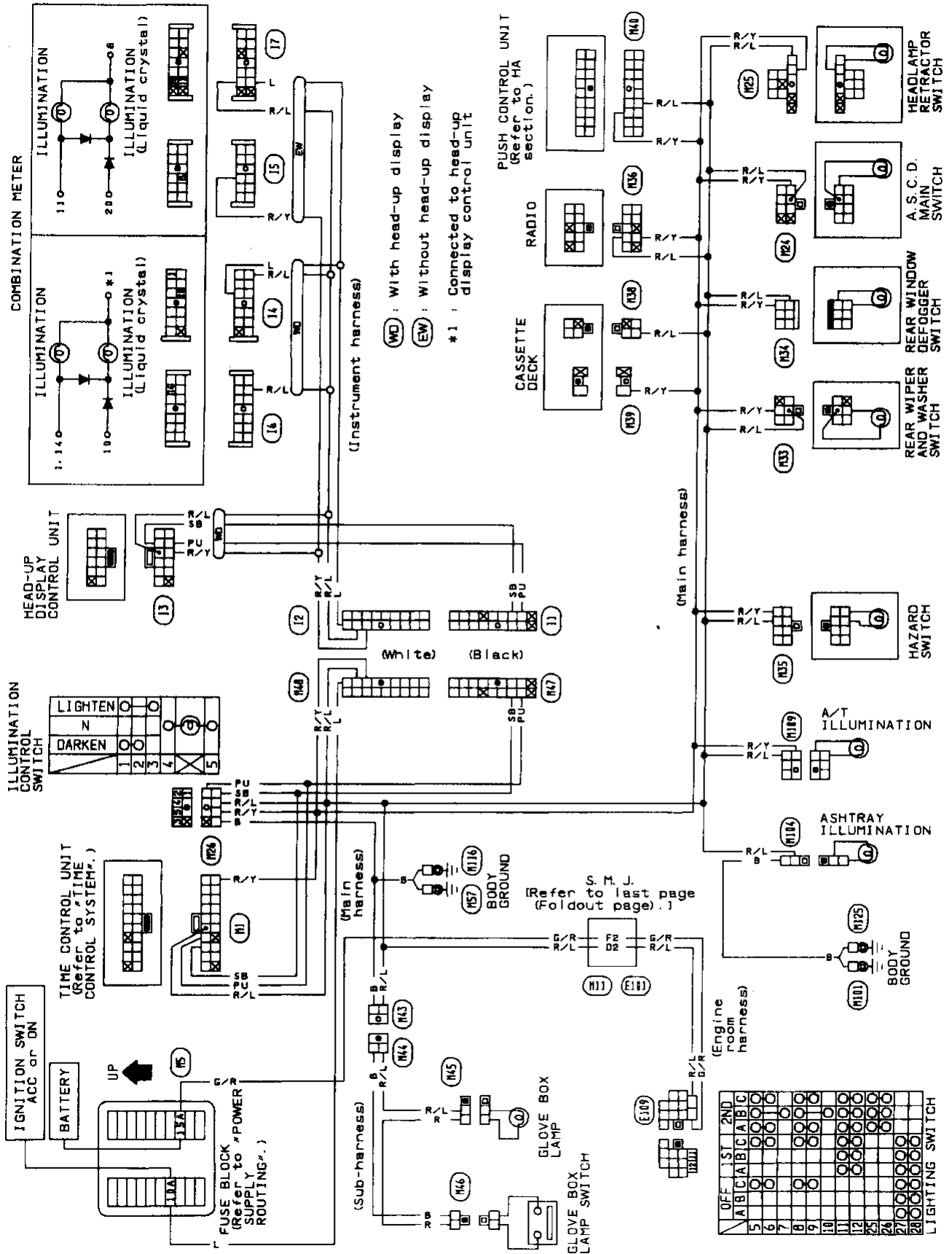

- GI
- MA
- EM
- LC
- EF & EC
- FE
- CL
- MT
- AT
- PD
- FA
- RA
- BR
- ST
- BF
- HA



# INTERIOR LAMP

## Interior Lamp/Wiring Diagram

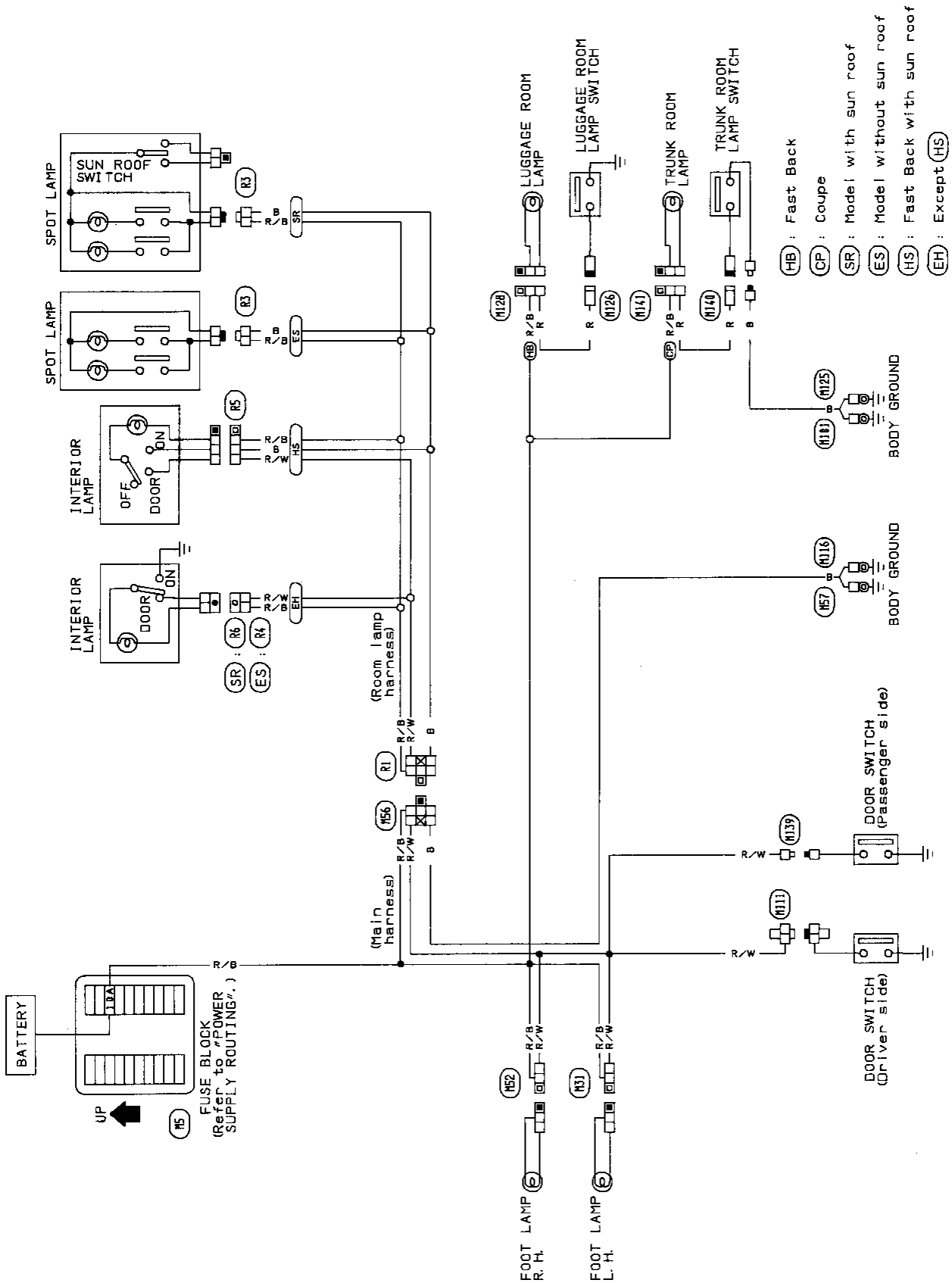

# METER AND GAUGES

## Combination Meter

### NEEDLE TYPE

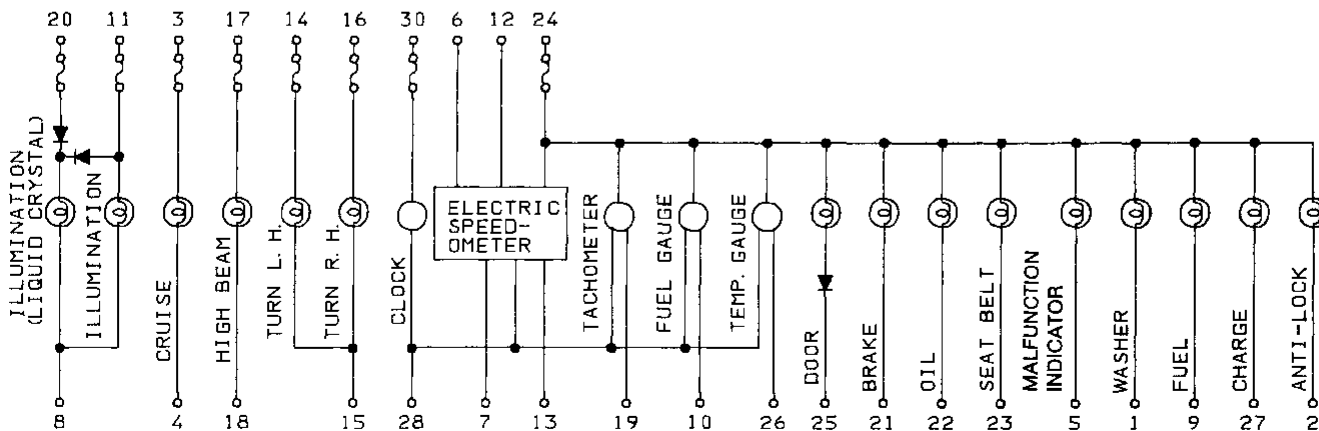
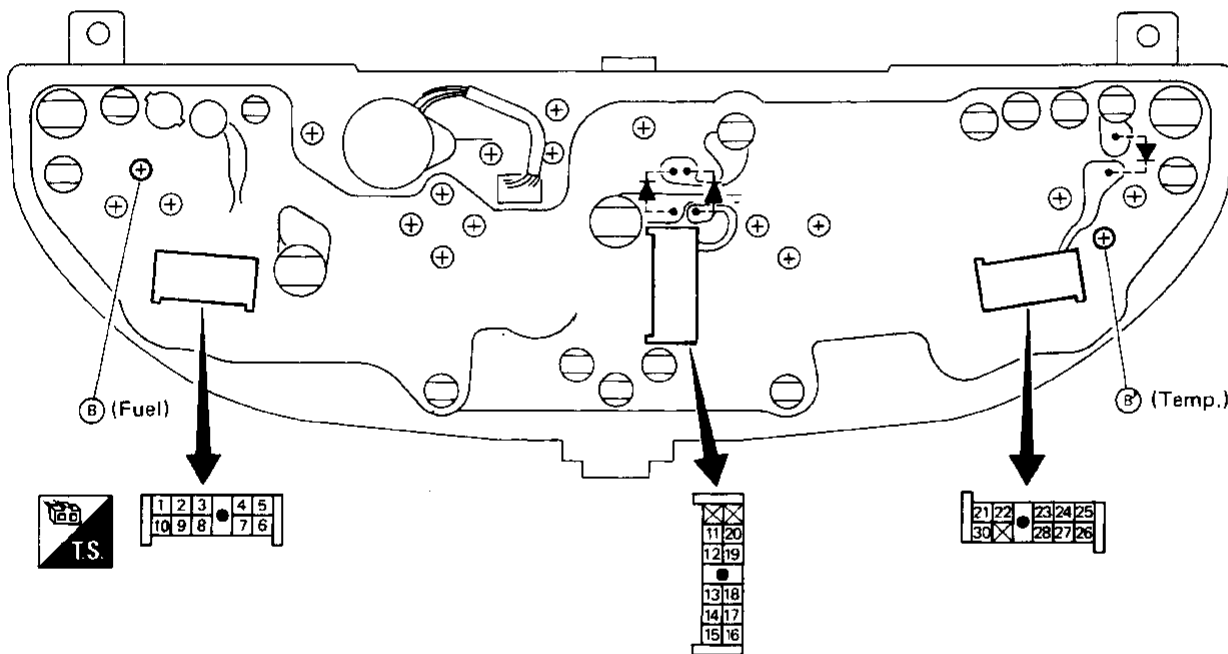
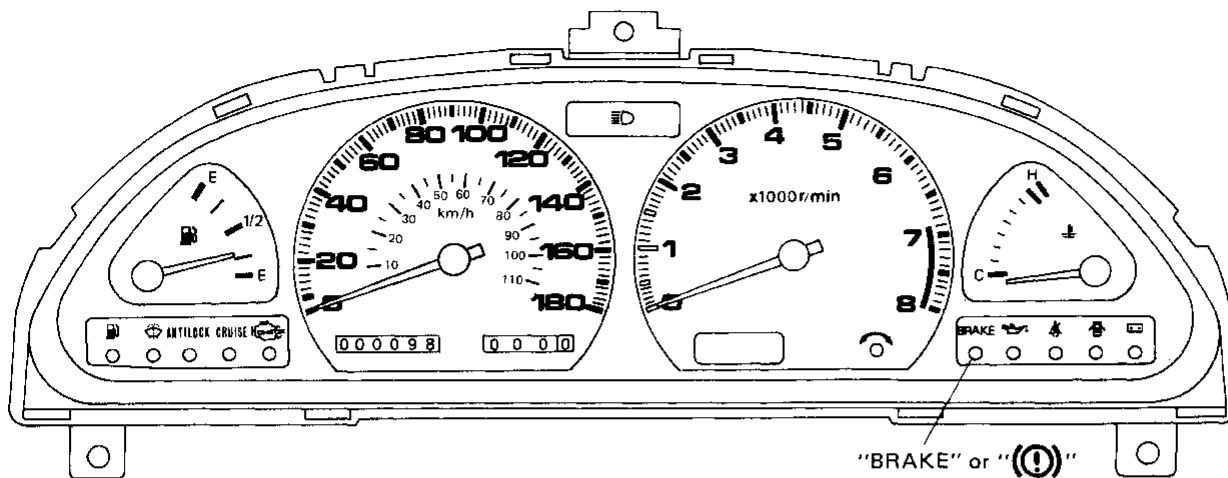

MEL725B

GI

MA

EM

LC

EF &  
EC

FE

CL

MT

AT

PD

FA

RA

BR

ST

BF

HA

EL

# METER AND GAUGES

## Combination Meter (Cont'd)

### DIGITAL TYPE

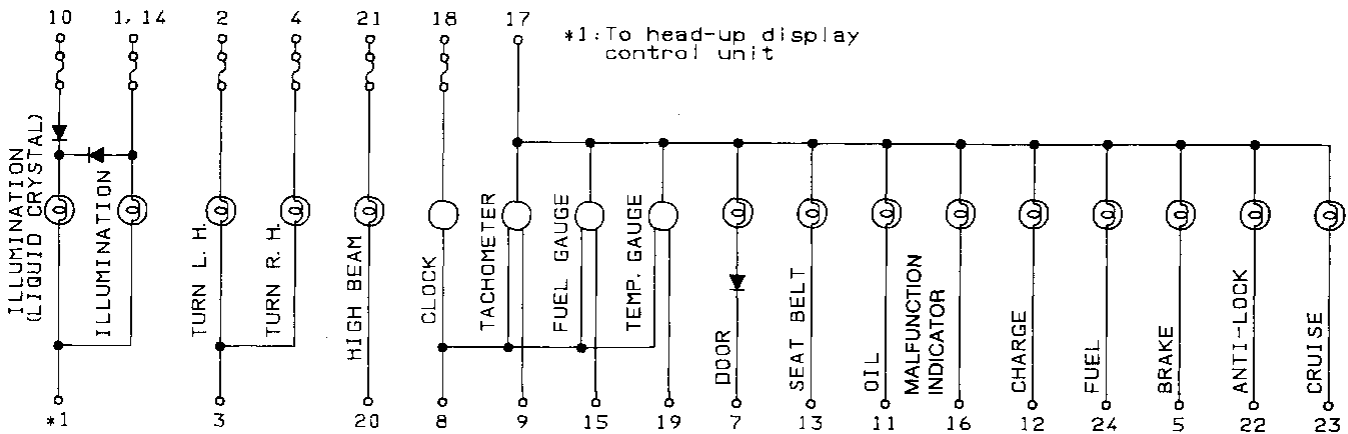
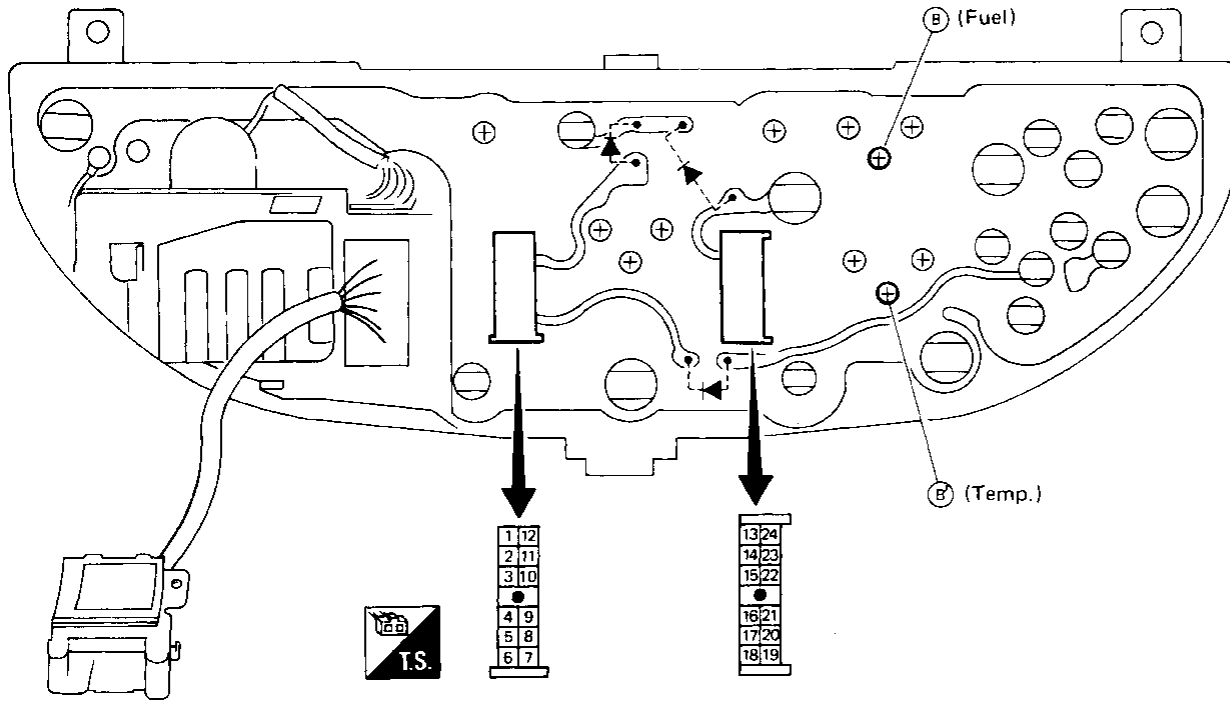
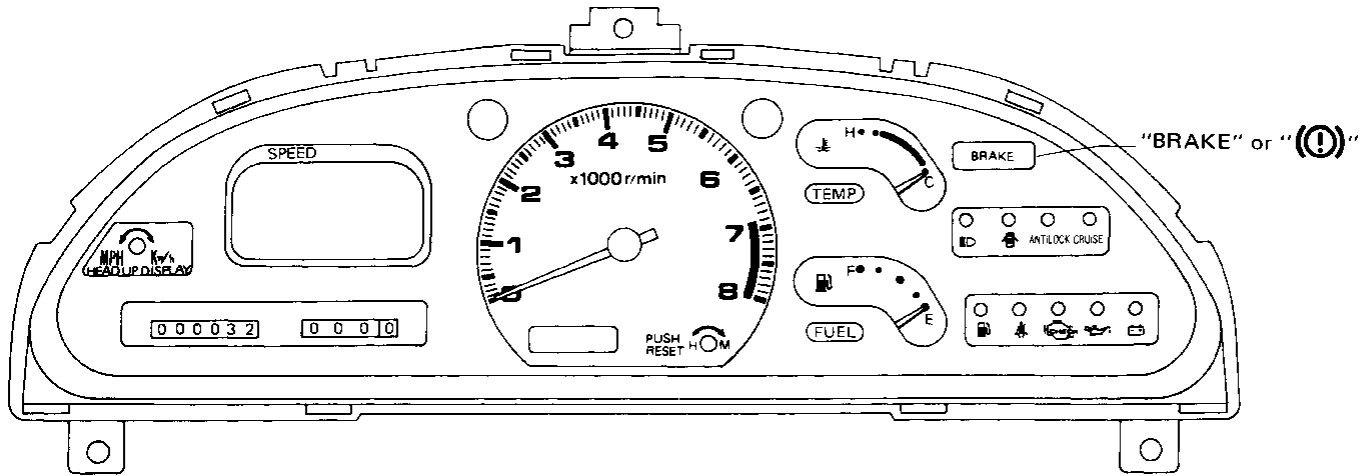



# METER AND GAUGES

## Combination Meter (Cont'd)

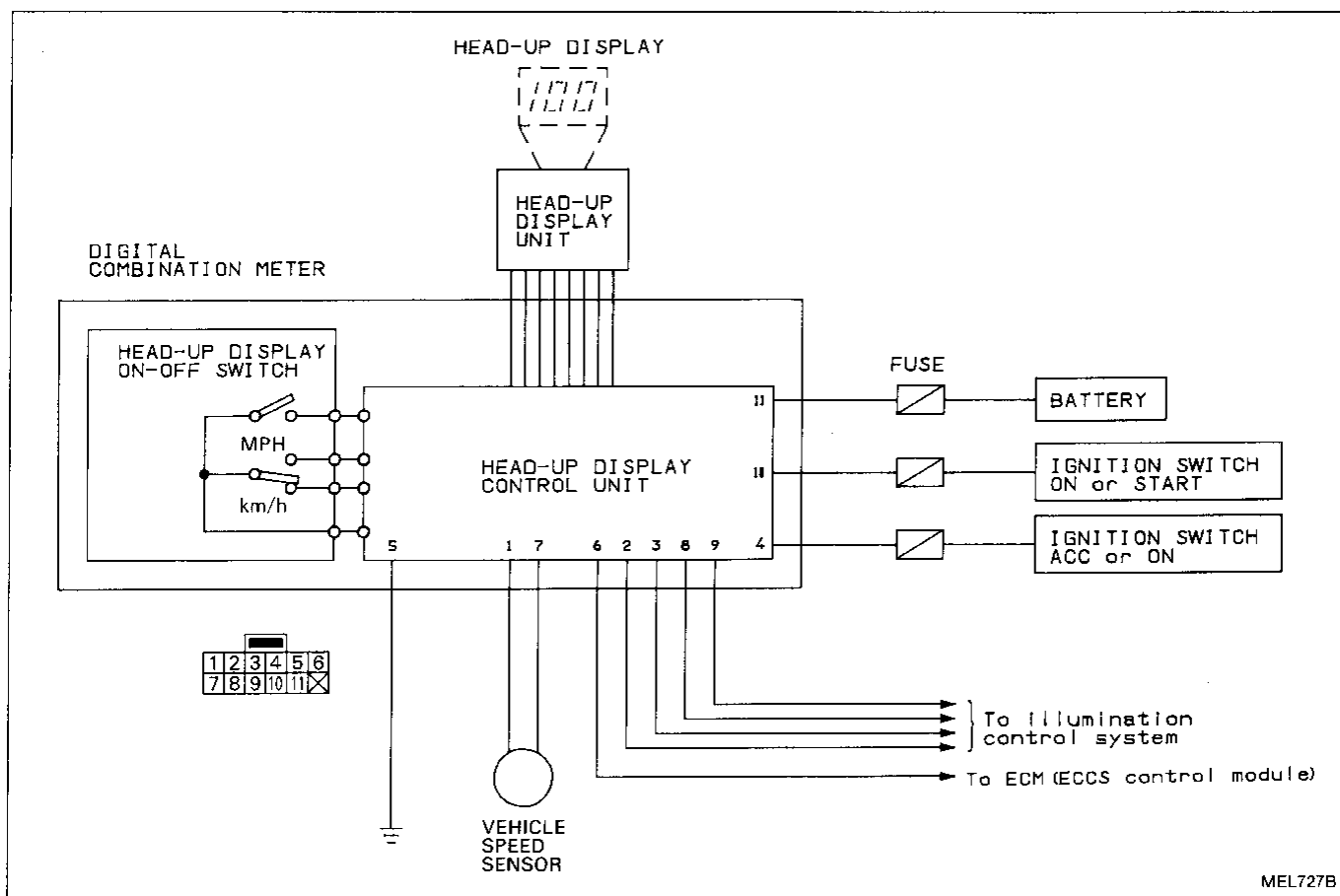

GI  
MA  
EM  
LC  
EF &  
EC  
FE  
CL  
MT  
AT  
PD  
FA  
RA  
BR  
ST  
BF  
HA

EL

Combination Meter/Wiring Diagram

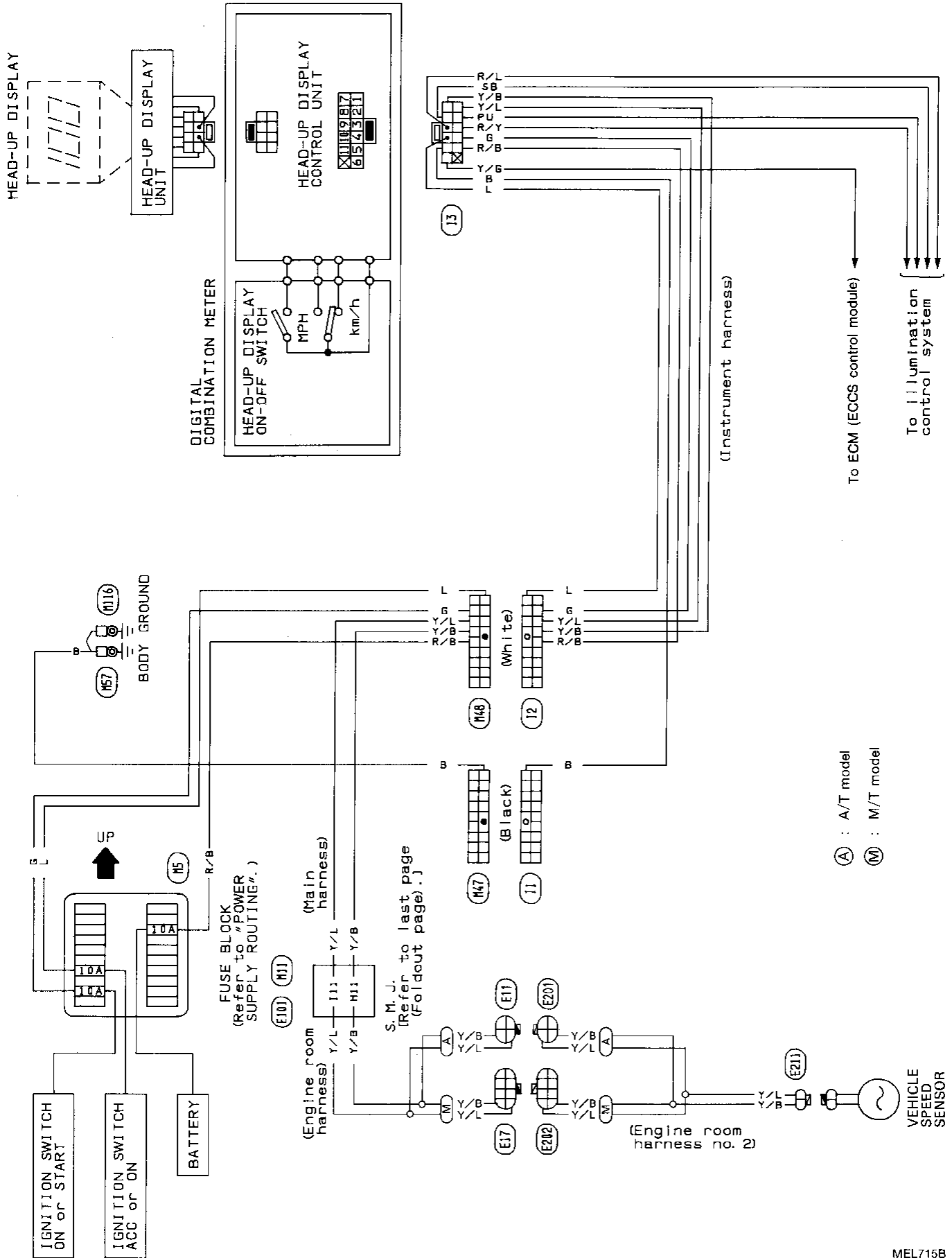

Speedometer, Tachometer, Temp. and Fuel Gauges/Wiring Diagram

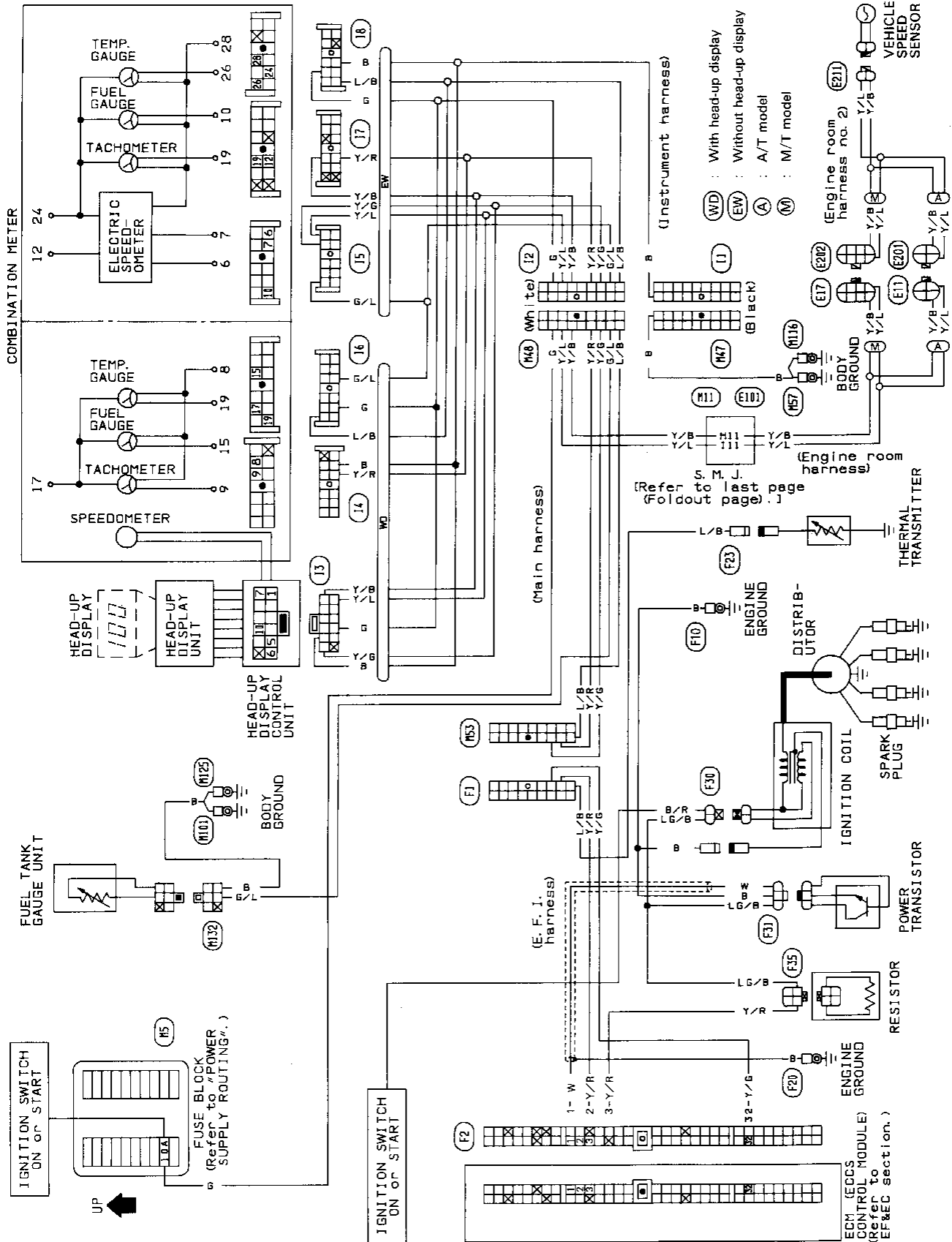

GI  
MA  
EM  
LC  
EF  
EC  
FE  
CL  
MT  
AT  
PD  
FA  
RA  
BR  
ST  
BF  
HA  
EL

## Inspection/Fuel Gauge and Water Temperature Gauge

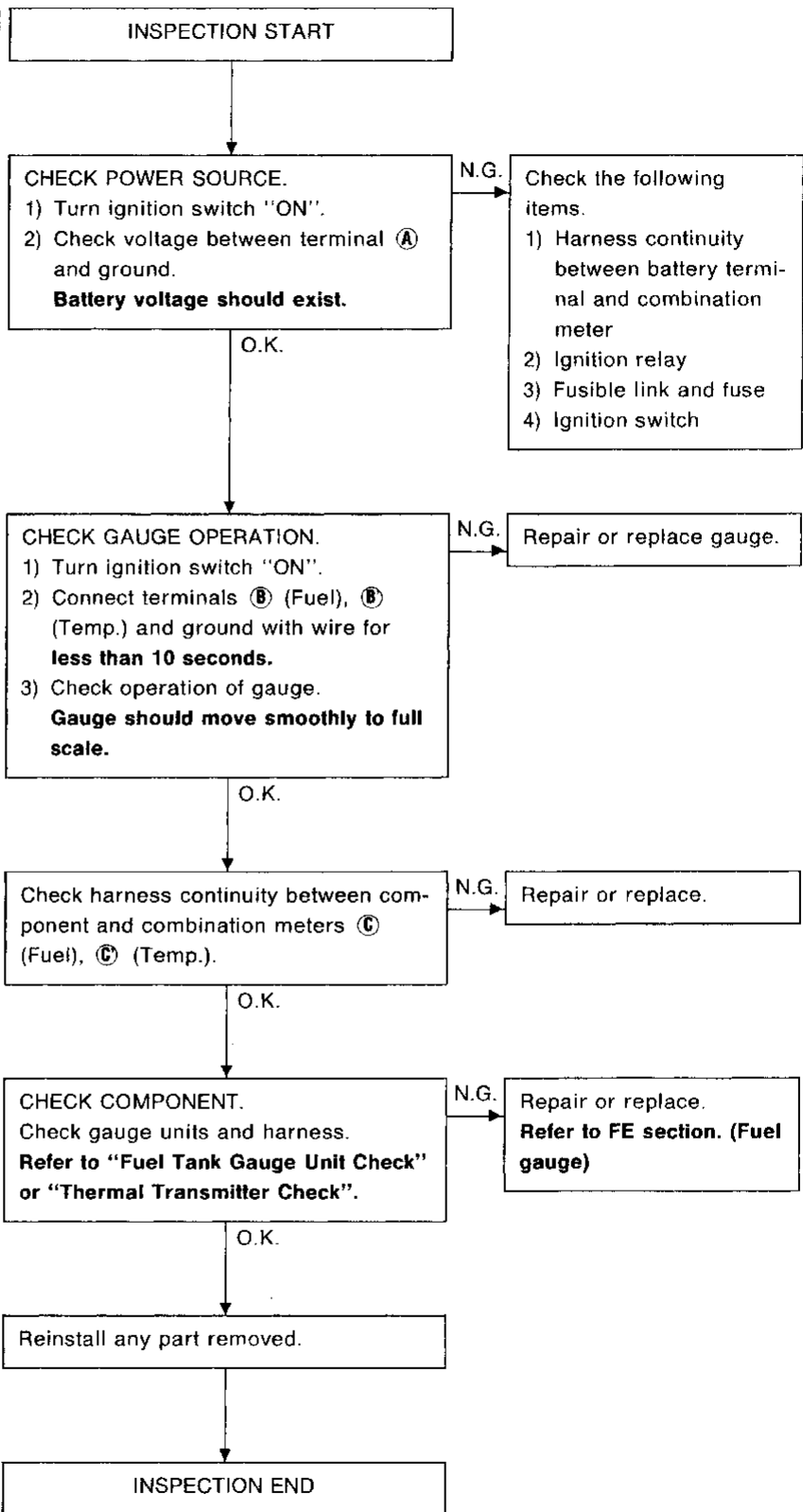
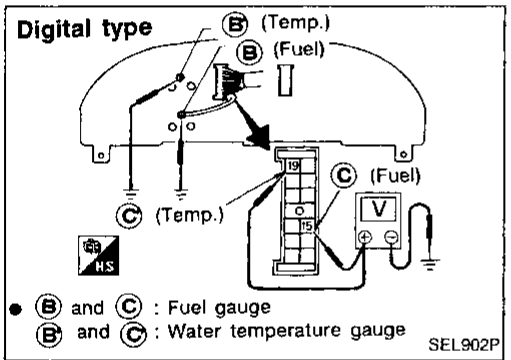
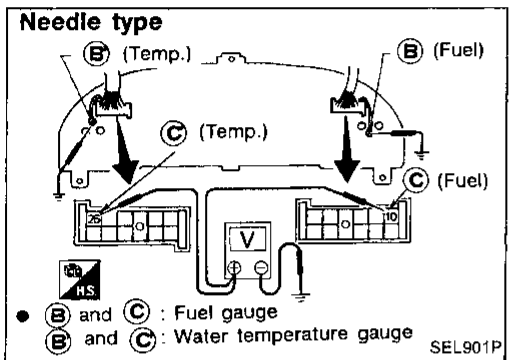
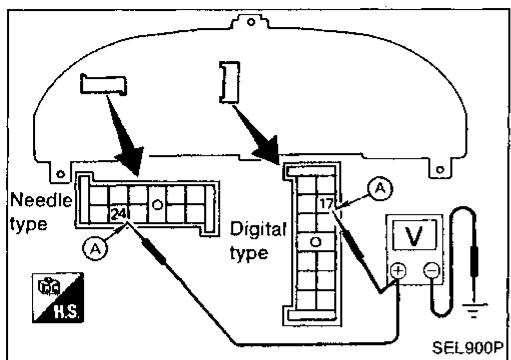

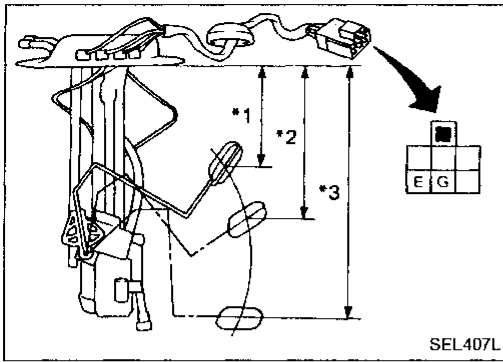

## Fuel Tank Gauge Unit Check

- For removal, refer to FE section.
- Check the resistance between terminals **G** and **E**.

Ohmmeter		Float position		Resistance Ω	Fuel value ℓ (US gal, Imp gal)
(+)	(-)		mm (in)		
G	E	*1	Full	Approx. 92 (3.62)	4.3 - 5.8 57.6 (15-1/4, 12-5/8)
		*2	1/2	Approx. 154 (6.06)	27.7 - 34.3 32.9 (8-3/4, 7-1/4)
		*3	Empty	Approx. 226 (8.90)	78.3 - 84.8 6.6 (1-3/4, 1-1/2)

GI

MA

EM

LC

EF &  
EC

FE

CL

MT

AT

PD

FA

RA

BR

ST

BF

HA

EL

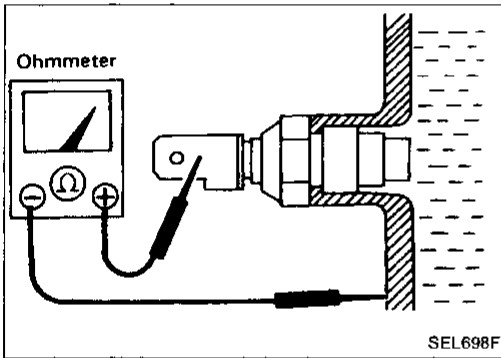

## Thermal Transmitter Check

- Check the resistance between the terminals of thermal transmitter and body ground.

Water temperature	Resistance
60°C (140°F)	Approx. 70 - 90Ω
100°C (212°F)	Approx. 21 - 24Ω

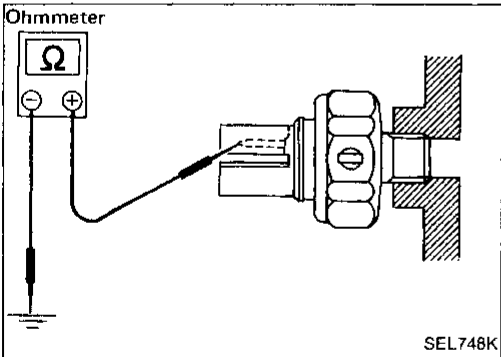

## Oil Pressure Switch Check

- Check the continuity between the terminals of oil pressure switch and body ground.

	Oil pressure kPa (kg/cm <sup>2</sup> , psi)	Continuity
Engine start	More than 10 - 20 (0.1 - 0.2, 1.4 - 2.8)	NO
Engine stop	Less than 10 - 20 (0.1 - 0.2, 1.4 - 2.8)	YES

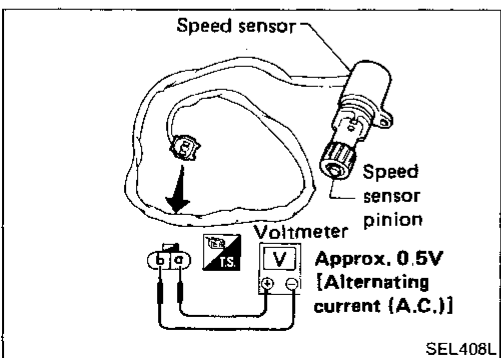

## Speed Sensor Signal Check

- Remove speed sensor from transmission.  
Location: Refer to "Location of Electrical Units".
- Turn speedometer pinion quickly and measure voltage across **a** and **b**.

Warning Lamps/Schematic

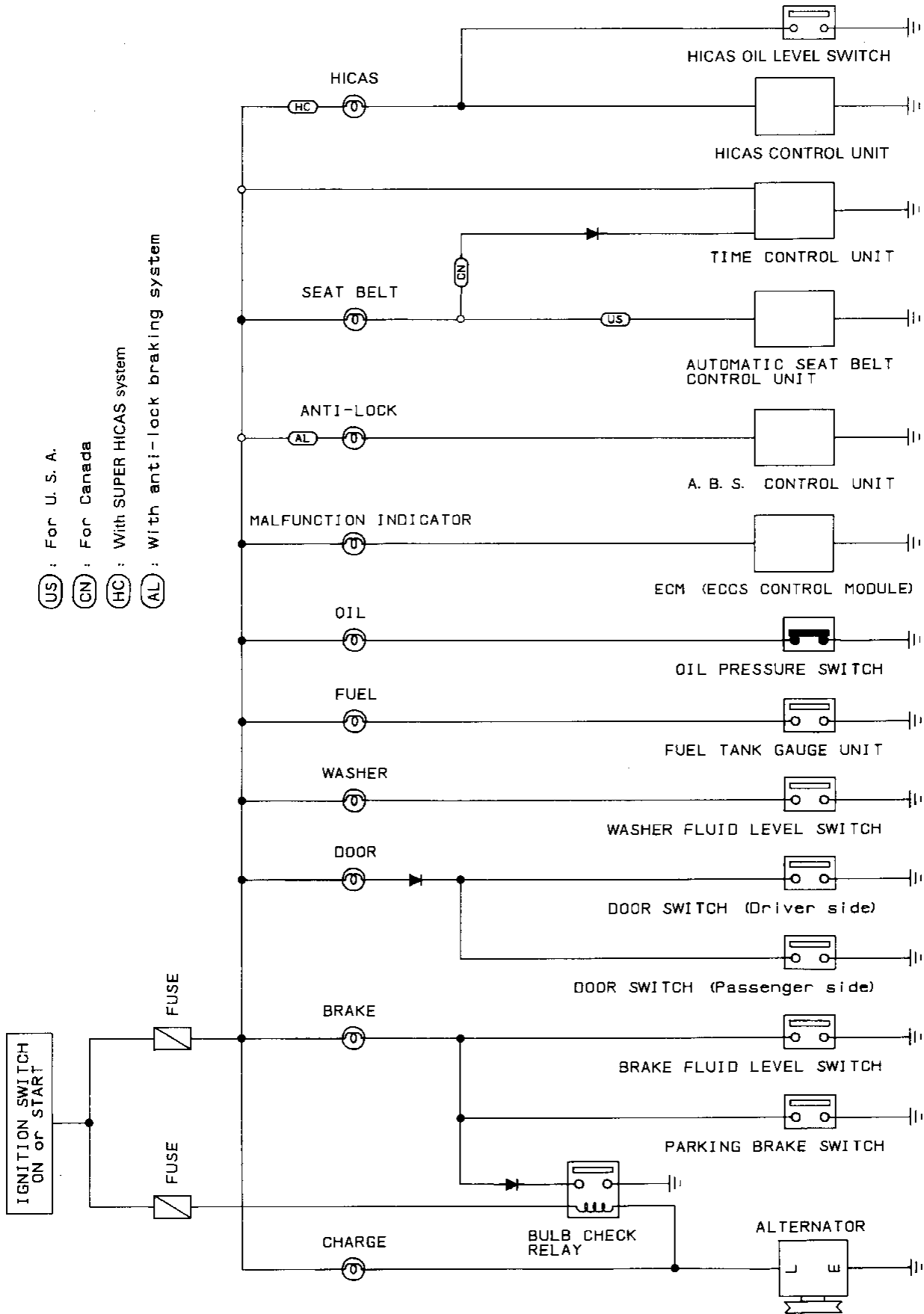

MEL717B

# WARNING LAMPS AND CHIME

## Warning Lamps/Wiring Diagram

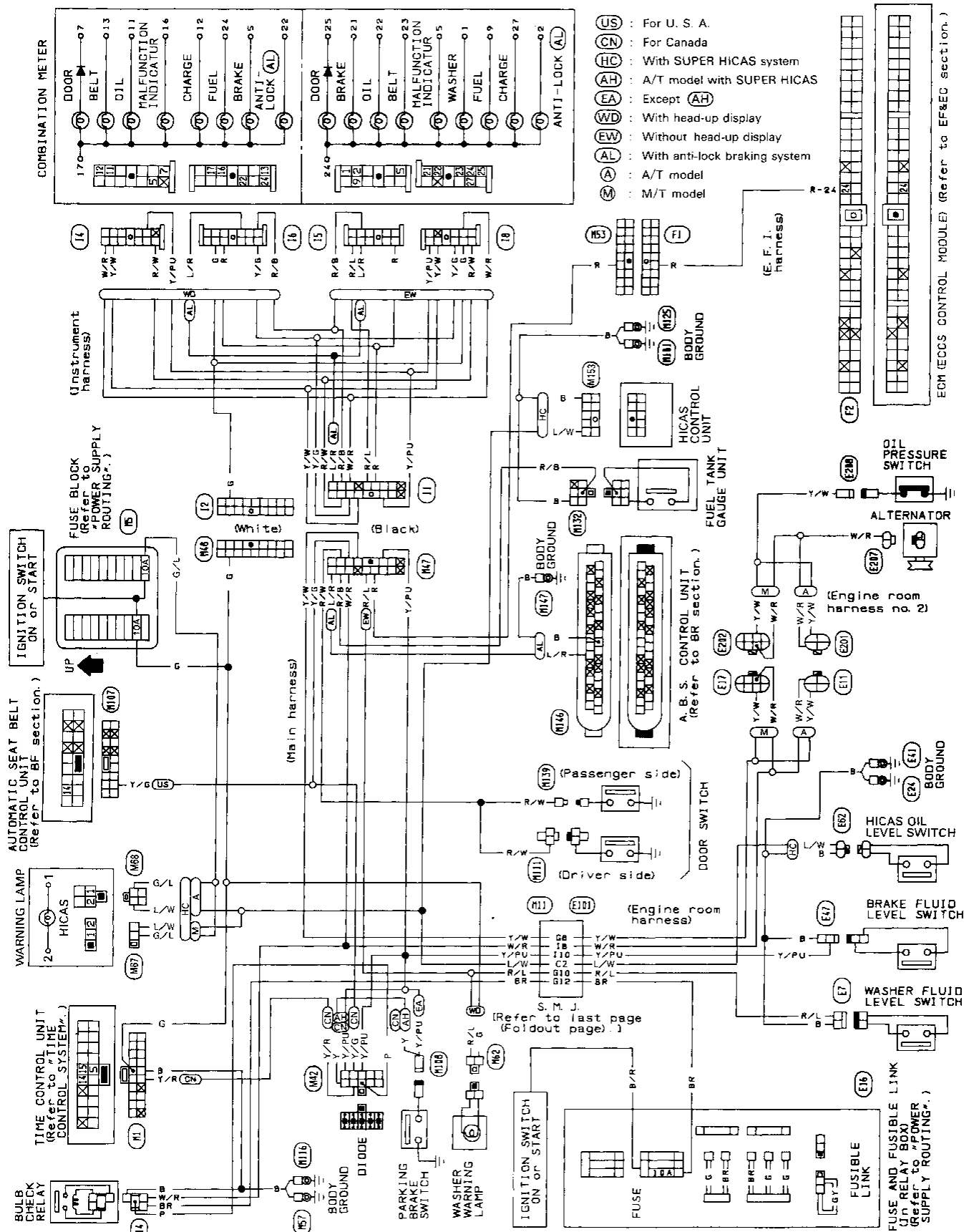

- (US) : For U. S. A.
- (CN) : For Canada
- (HC) : With SUPER HICAS system
- (AH) : A/T model with SUPER HICAS
- (EA) : Except (AH)
- (WD) : With head-up display
- (EV) : Without head-up display
- (AL) : With anti-lock braking system
- (A) : A/T model
- (M) : M/T model

GI  
MA  
EM  
LC  
EF &  
EC  
FE  
CL  
MT  
AT  
PD  
FA  
RA  
BR  
ST  
BF  
HA  
EL

# WARNING LAMPS AND CHIME

## Warning Chime/Wiring Diagram

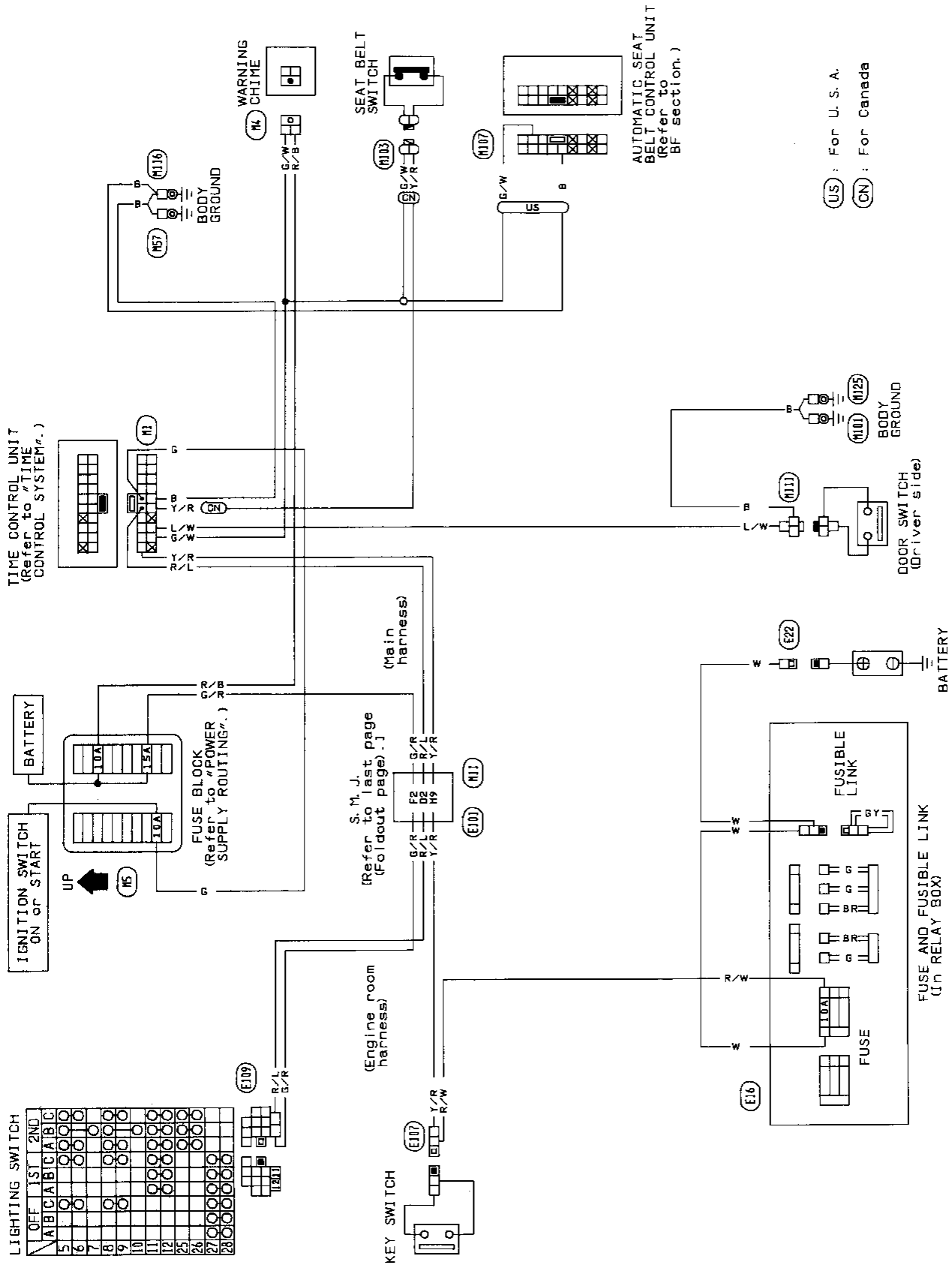



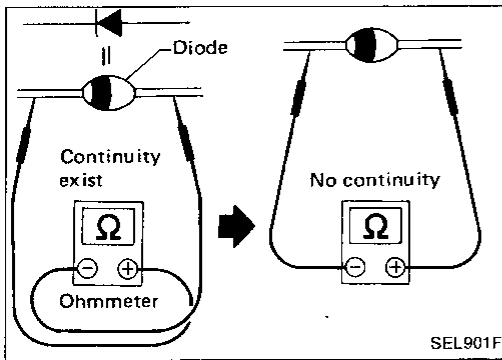

## Diode Check

- Check continuity using an ohmmeter.
- Diode is functioning properly if test results are as shown in the figure at left.

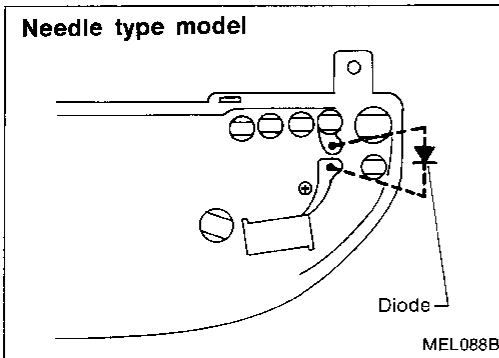

- Diodes for warning lamps are built into the combination meter printed circuit.

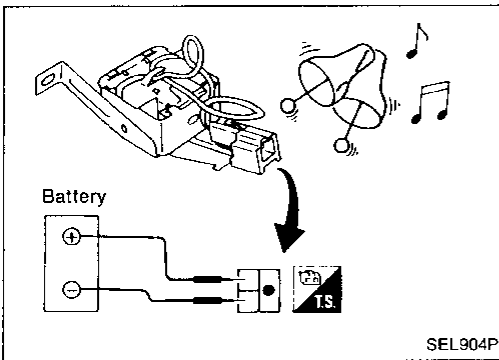

## Warning Chime Check

GI

MA

EM

LC

EF &  
EC

FE

CL

MT

AT

PD

FA

RA

BR

ST

BF

HA

EL

# TIME CONTROL SYSTEM

## Schematic

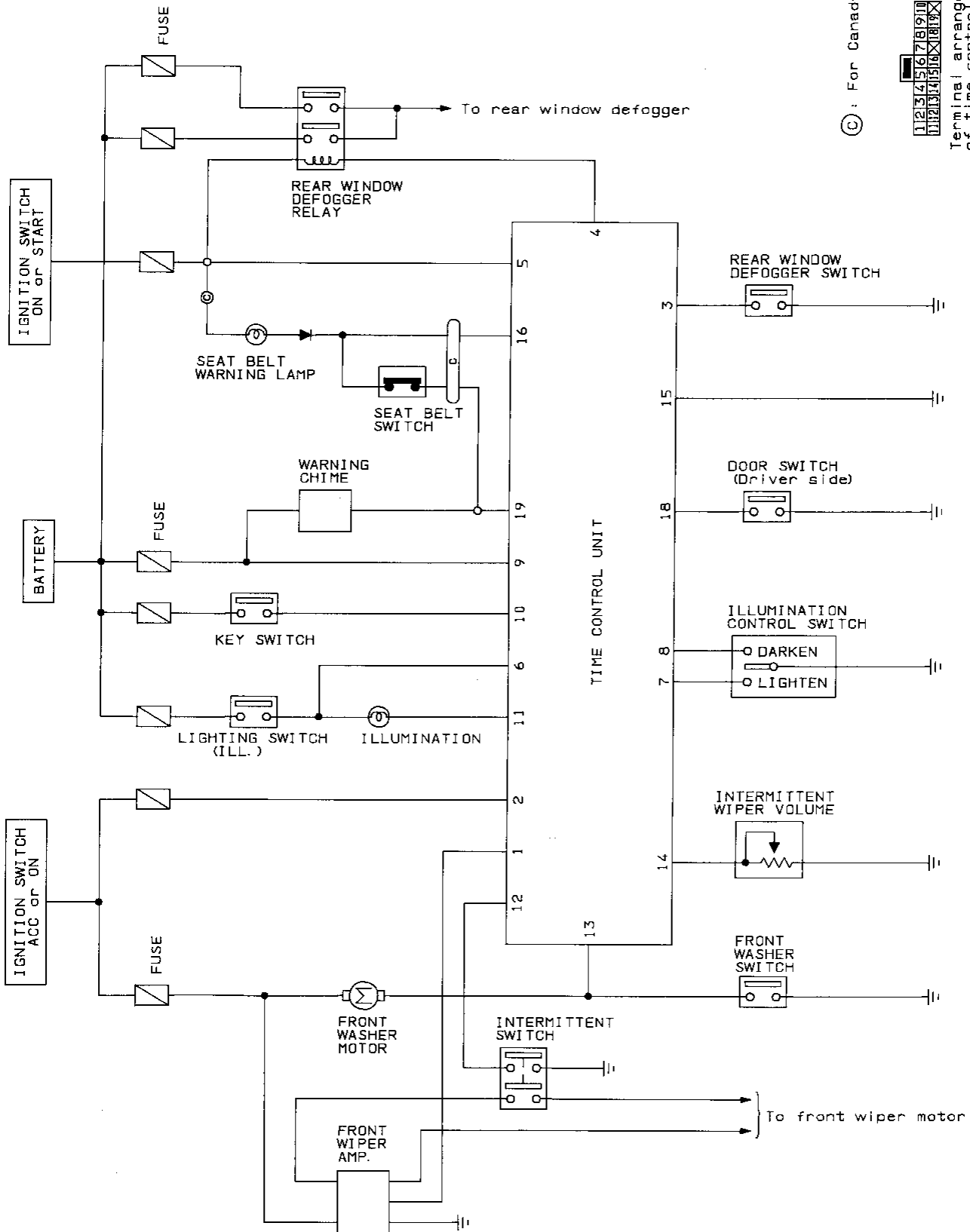

© : For Canada

1 2 3 4 5 6 7 8 9 10  
 11 12 13 14 15 16 17 18 19 X

Terminal arrangement  
 of time control unit

# TIME CONTROL SYSTEM

## Wiring Diagram

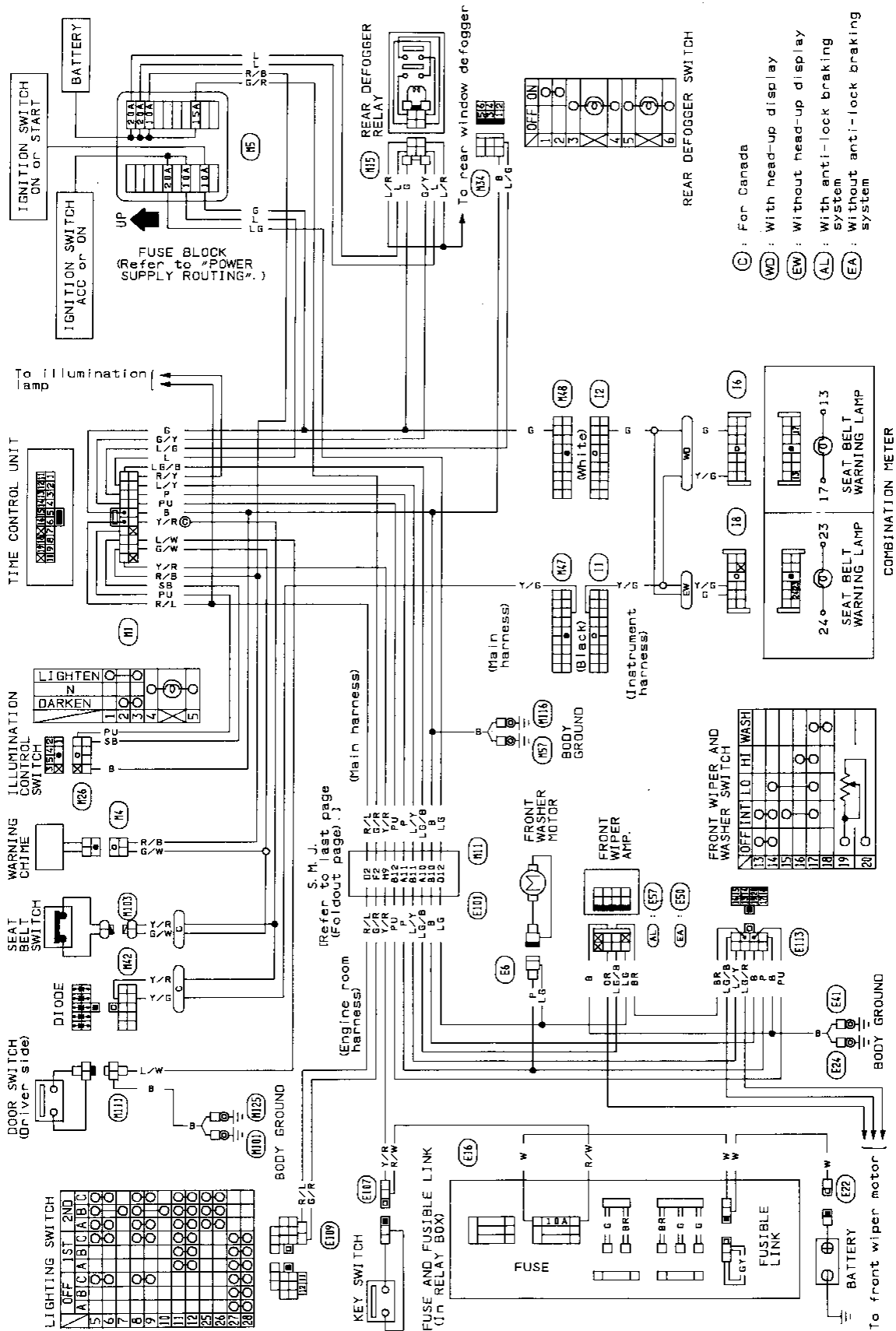

GI  
 MA  
 EM  
 LC  
 EF &  
 EC  
 FE  
 CL  
 MT  
 AT  
 PD  
 FA  
 RA  
 BR  
 ST  
 BF  
 HA

EL

# TIME CONTROL SYSTEM

## Description

### FUNCTION

- Time control unit has the following functions.

Item		Details of control
1	Intermittent wiper control	Regulates intermittent time from approximately 3 to 12 seconds depending on the intermittent wiper volume setting.
2	Washer and wiper combination control	Wiper is operated in conjunction with washer switch.
3	Illumination control	Regulates brightness of illumination in 16 stages depending on the illumination control switch setting.
4	Light warning chime timer	When driver's door is opened with light switch ON and ignition switch OFF, warning chime sounds.
5	Seat belt warning lamp timer	Seat-belt warning lamp blinks for about 7 seconds when ignition switch is turned to "ON".
6	Seat belt warning chime timer	Sounds warning chime for about 7 seconds if ignition switch is turned "ON" when seat belt switch is "ON" (seat belt is unfastened).

### OPERATING CONDITIONS

Item	Input signal Input terminal Output terminal	Power source from battery	Ignition switch	Light switch	Wiper switch "INT"	Washer switch	Driver's side door switch *1	Seat belt switch *2	Illumination control switch
		⑨	② or ⑤	⑥	⑫	⑬	⑱	⑲	⑦ or ⑧
Intermittent wiper control	①	ON	ACC or ON		ON				
Washer and wiper combination control	⑫	ON	ACC or ON			ON			
Illumination control	⑪	ON		ON					ON
Light warning chime timer	⑲	ON	OFF or ACC	ON			ON		
Seat belt warning lamp timer	⑲	ON	OFF or ACC → ON						
Seat belt warning chime timer	⑲	ON	OFF or ACC → ON					ON	

\*1 Door switch is turned ON when door is opened.

\*2 Seat belt switch is turned ON when driver's side seat belt is unfastened.

# TIME CONTROL SYSTEM

## Trouble-shooting

Symptom		DIAGNOSTIC PROCEDURE
Wiper & washer	Intermittent wiper does not operate.	1
	Intermittent time of wiper cannot be adjusted.	2
	Wiper and washer activate individually but not in combination	3
Illumination	Illumination control system does not actuate.	4
Warning	Light warning chime does not activate.	5
	Seat belt warning chime does not activate.	6
	Seat belt warning lamp does not go off nor	7
	Ignition key warning chime does not activate.	9
Rear defogger	Rear defogger does not activate, or does not go off.	8

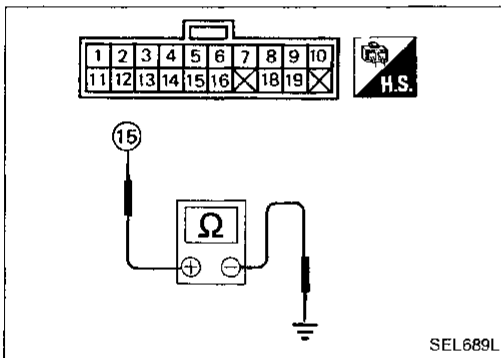

### PREPARATION FOR TROUBLE-SHOOTING

1. Remove driver's side dash side cover.
2. Remove time control unit with harness connected.

### POWER SUPPLY CIRCUIT CHECK

1. Connect ohmmeter from harness side.
2. Check continuity between terminal 15 and body ground.

Ohmmeter terminals		Continuity
(+)	(-)	
15	Body ground	Yes

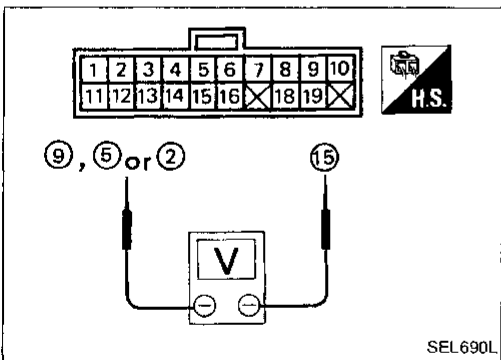

3. Connect voltmeter from harness side.
4. Measure voltage across terminal 15 and terminals 2, 5 or 9.

Voltmeter terminals		Ignition switch position		
(+)	(-)	OFF	ACC	ON
9	15	Approx. 12V	Approx. 12V	Approx. 12V
5	15	0V	0V	Approx. 12V
2	15	0V	Approx. 12V	Approx. 12V

# TIME CONTROL SYSTEM

## Trouble-shooting (Cont'd)

### DIAGNOSTIC PROCEDURE-1

Intermittent wiper does not operate.

**A T.C.U. OUTPUT FOR WIPER RELAY CIRCUIT CHECK**  
Measure voltage across ① and ⑮.

Wiper switch → "INT"  
Needle swings from 0 to 12V every 3 to 12 seconds.

SEL652L

**B WIPER SWITCH CIRCUIT CHECK**  
Check continuity between ⑫ and ⑮.

Wiper switch  
"INT": 0V  
"OFF": 12V

SEL653L

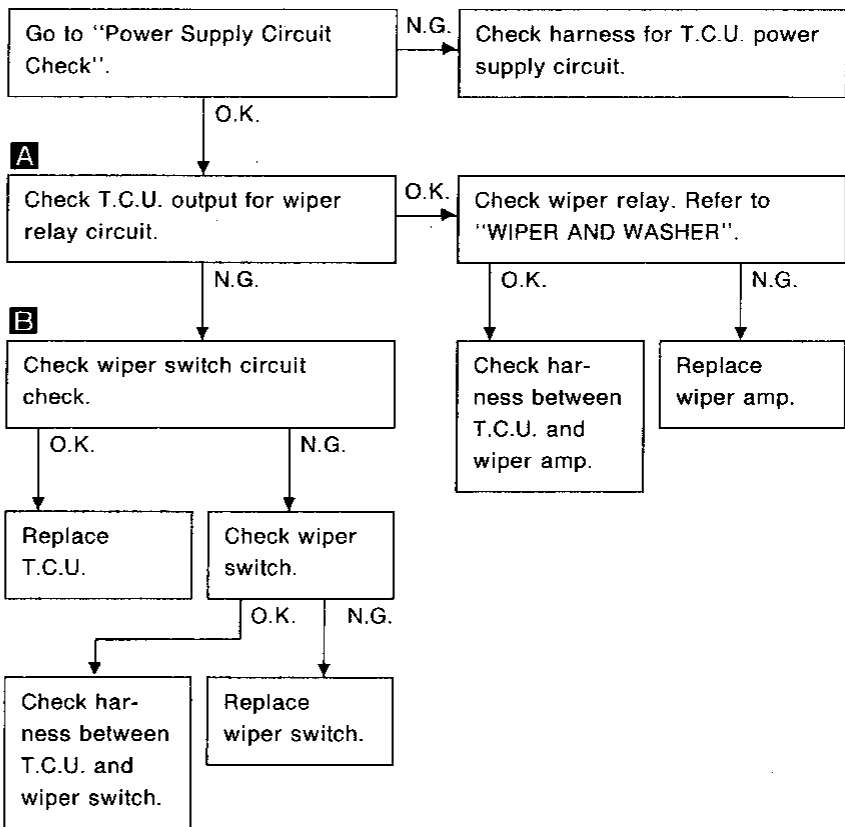

**A INTERMITTENT WIPER VOLUME CIRCUIT CHECK**  
Measure resistance between ⑭ and ⑮ while turning intermittent wiper volume.

Intermittent wiper knob  
0Ω at "S" position  
Approx. 1 kΩ at "L" position

SEL654L

### DIAGNOSTIC PROCEDURE-2

Intermittent time of wiper cannot be adjusted.

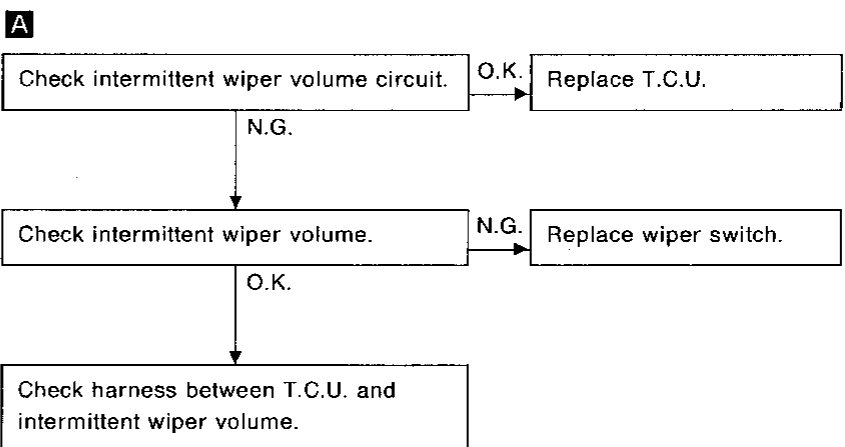

# TIME CONTROL SYSTEM

## Trouble-shooting (Cont'd)

### DIAGNOSTIC PROCEDURE-3

Wiper and washer activate individually but not in combination.

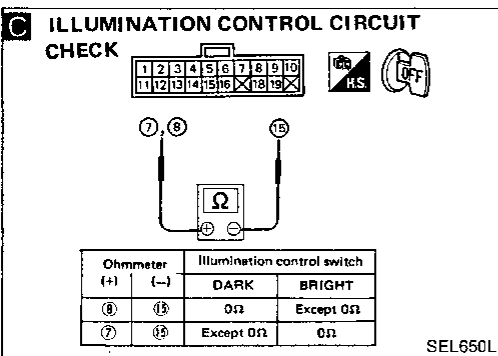
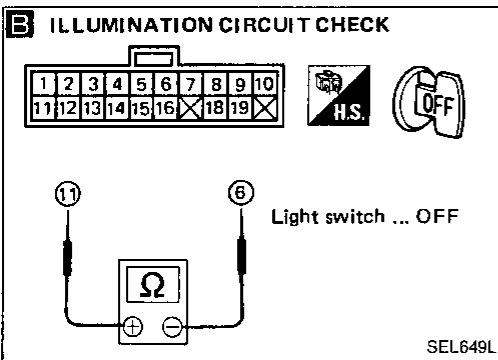
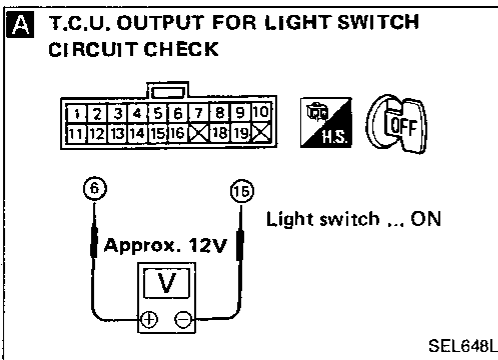
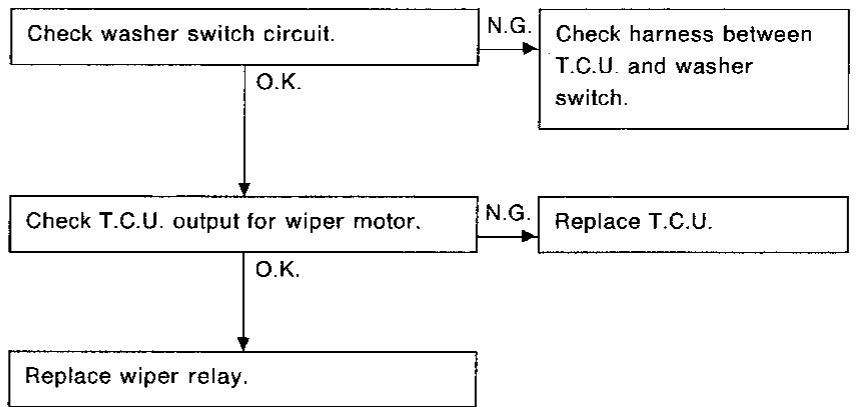

### DIAGNOSTIC PROCEDURE-4

Illumination control system does not actuate.

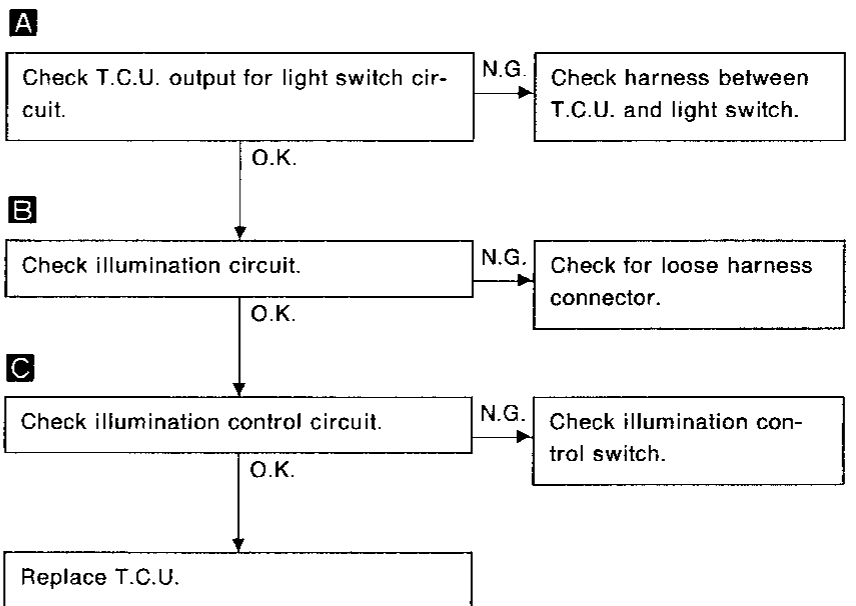

GI  
MA  
EM  
LC  
EF & EC  
FE  
CL  
MT  
AT  
PD  
FA  
RA  
BR  
ST  
BF  
HA  
EL

# TIME CONTROL SYSTEM

## Trouble-shooting (Cont'd)

### DIAGNOSTIC PROCEDURE-5

Light warning chime does not activate.

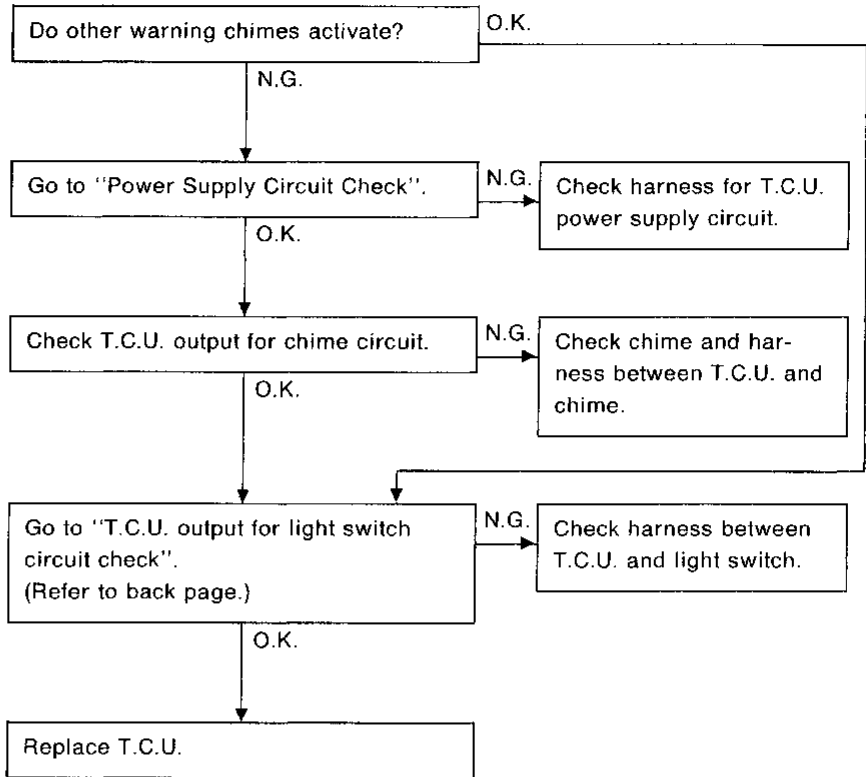

#### A T.C.U. OUTPUT FOR CHIME CIRCUIT CHECK

Measure voltage across ⑲ and ⑮ when driver's door is opened and closed.



- Approx. 12V when driver's side door is closed.
- Voltmeter needle swings (0 ↔ 12V) when driver's side door is opened.

SEL642L

#### B SEAT BELT SWITCH CIRCUIT CHECK

1. Unfasten driver's seat belt.
2. Check continuity between ⑲ and ⑮.
3. Fasten driver's seat belt.
4. Check to determine if continuity does not exist between ⑲ and ⑮.

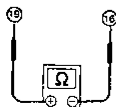

SEL643L

### DIAGNOSTIC PROCEDURE-6

Seat belt warning chime does not activate.

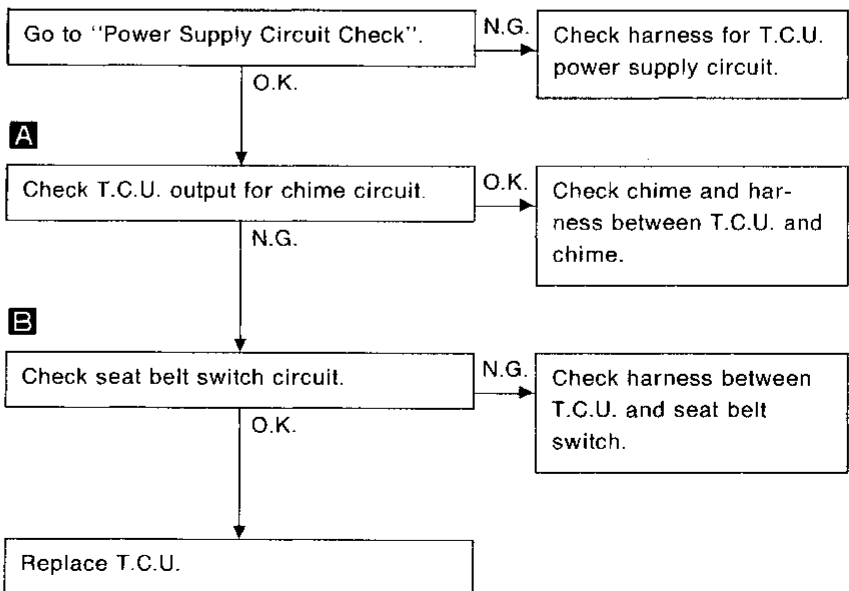



# TIME CONTROL SYSTEM

## Trouble-shooting (Cont'd)

### DIAGNOSTIC PROCEDURE-7

Seat belt warning lamp does not go off nor comes on.

**T.C.U. OUTPUT FOR BELT WARNING LAMP CIRCUIT CHECK**  
 Measure voltage across ⑬ and ⑮ when ignition switch is "ON".

SEL651L

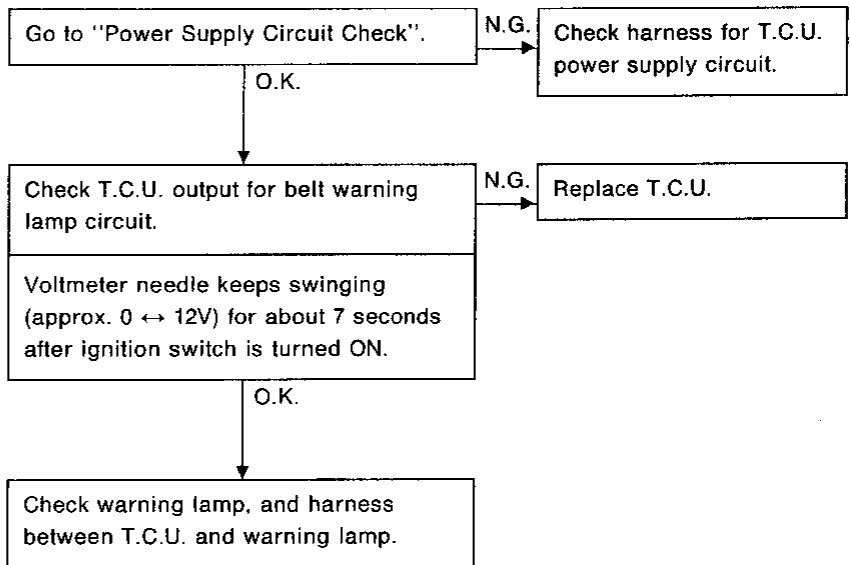

**A T.C.U. OUTPUT FOR REAR DEFOGGER CIRCUIT CHECK**  
 Measure voltage across ④ and ⑮ while operating rear defogger switch.

- Rear defogger switch "OFF": Approx. 12V
- Rear defogger switch "ON": Approx. 0V

SEL644L

### DIAGNOSTIC PROCEDURE-8

Rear defogger does not activate, or does not go off.

**B DEFOGGER SWITCH CIRCUIT CHECK**

- Rear defogger switch "OFF": Except 0Ω
- Rear defogger switch "ON": 0Ω

SEL645L

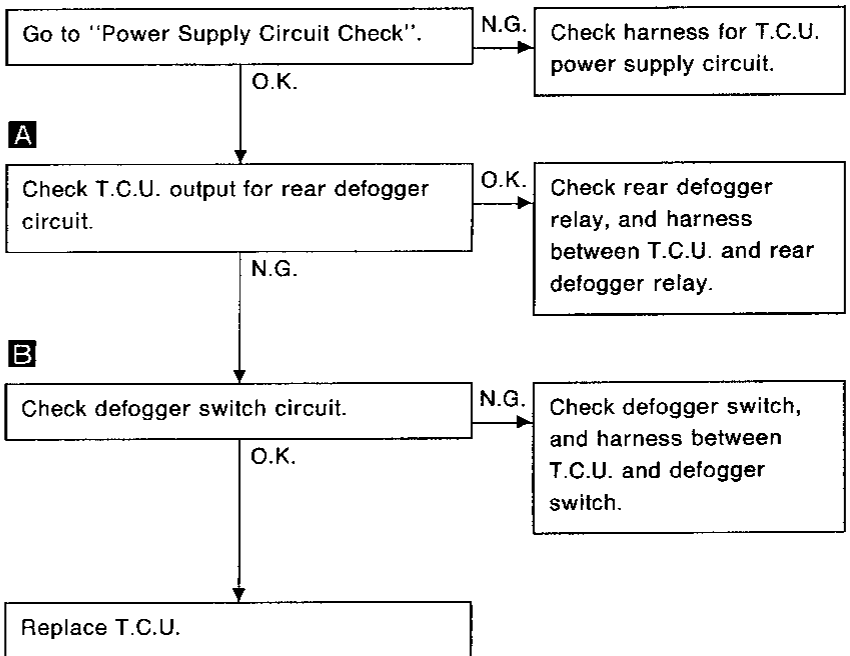

GI  
 MA  
 EM  
 LC  
 EF & EC  
 FE  
 CL  
 MT  
 AT  
 PD  
 FA  
 RA  
 BR  
 ST  
 BF  
 HA

EL

# TIME CONTROL SYSTEM

## Trouble-shooting (Cont'd)

### DIAGNOSTIC PROCEDURE-9

Ignition key warning chime does not activate.

**A KEY SWITCH CIRCUIT CHECK**  
Measure voltage across ⑩ and ⑮.

SEL773R

**B T.C.U. OUTPUT FOR CHIME CIRCUIT CHECK**  
Measure voltage across ⑲ and ⑮ when driver's door is opened and closed.

- Approx. 12V when driver's side door is opened.

SEL639L

**C DRIVER'S DOOR SWITCH CIRCUIT CHECK**  
Check continuity between ⑱ and ⑮.

Driver's side door ... Open

SEL640L

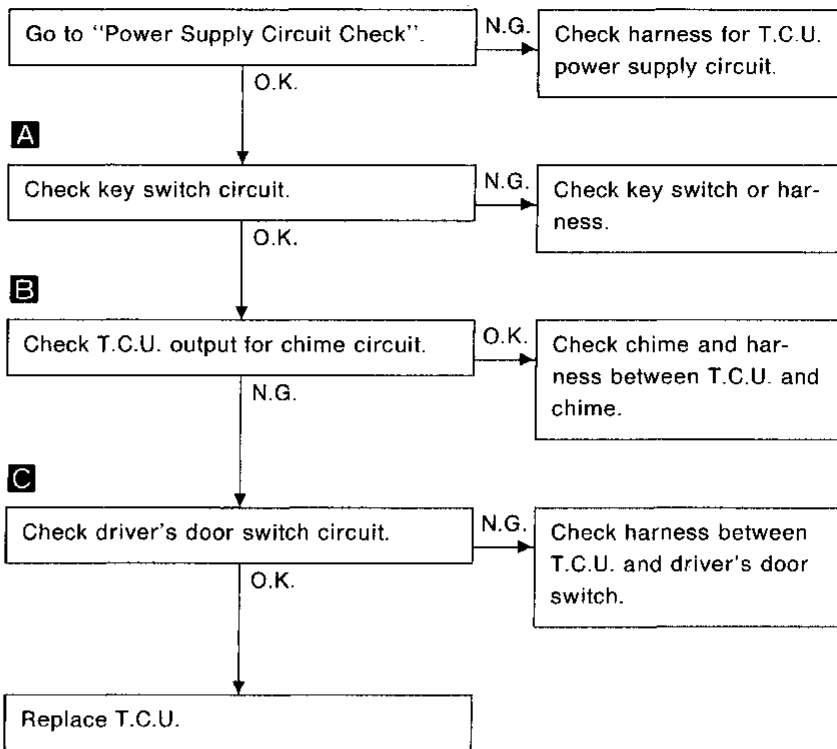



# WIPER AND WASHER

## Rear Wiper and Washer/Wiring Diagram

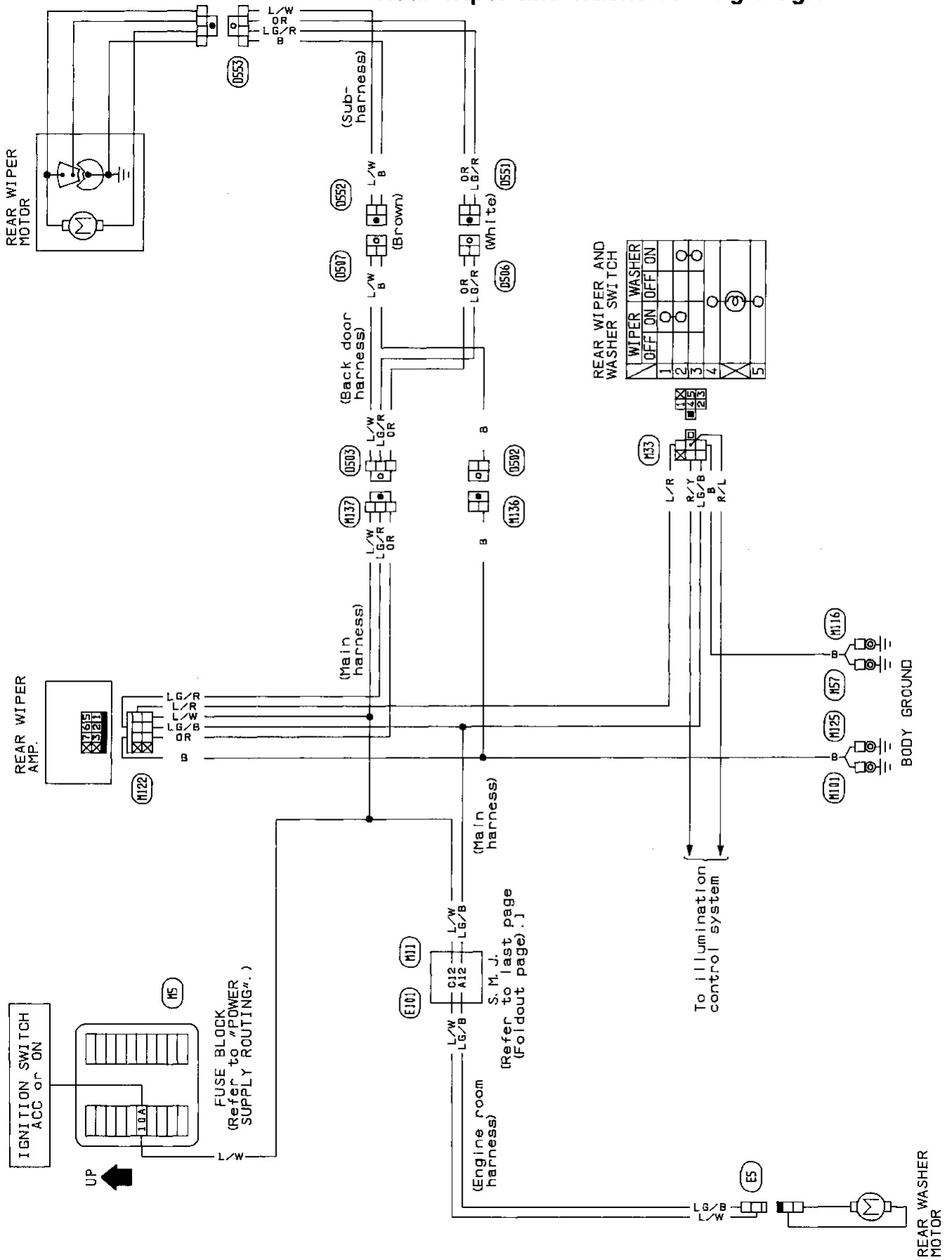

SEL671M

## Wiper and Washer Adjustment

### INSTALLATION

1. Prior to wiper arm installation, turn on wiper switch to operate wiper motor and then turn it "OFF" (Auto Stop).
2. Lift the blade up and then set it down onto glass surface to set the blade center to clearance "L<sub>1</sub>" & "L<sub>2</sub>" immediately before tightening nut.
3. Eject washer fluid. Turn on wiper switch to operate wiper motor and then turn it "OFF".
4. Ensure that wiper blades stop within clearance "L<sub>1</sub>" & "L<sub>2</sub>".

**Clearance "L<sub>1</sub>": 17.5 - 32.5 mm (0.689 - 1.280 in)**

**Clearance "L<sub>2</sub>": 25 - 35 mm (0.98 - 1.38 in)**

- Tighten wiper arm nuts to specified torque.

**Front wiper: 17 - 23 N·m (1.7 - 2.3 kg·m, 12 - 17 ft·lb)**

**Rear wiper: 13 - 18 N·m (1.3 - 1.8 kg·m, 9 - 13 ft·lb)**

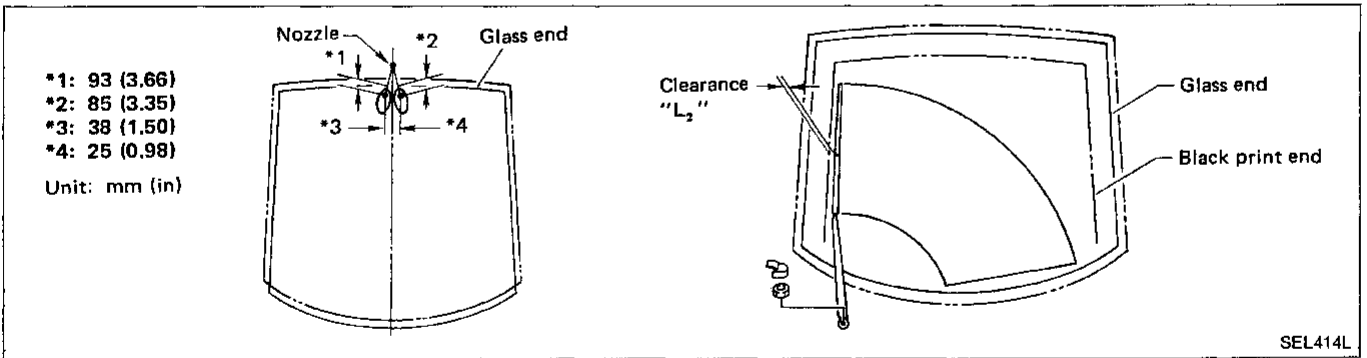
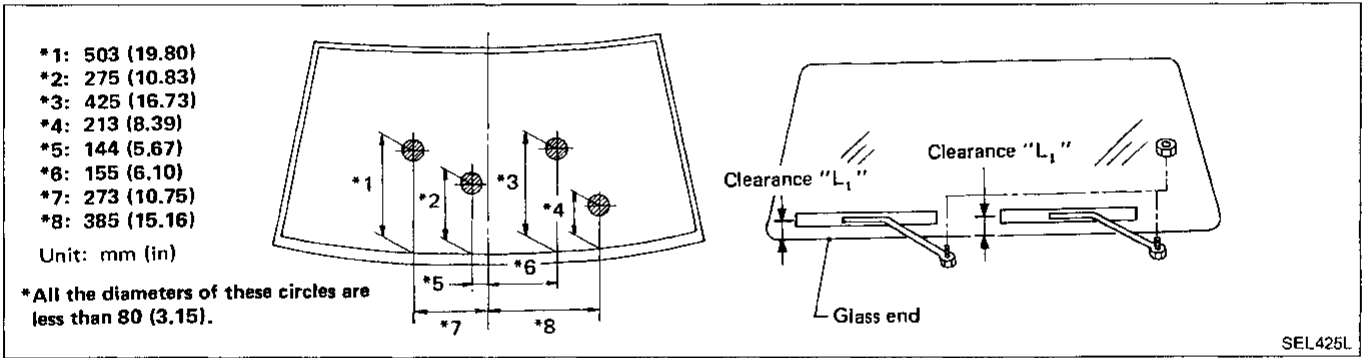

GI  
 MA  
 EM  
 LC  
 EF & EC  
 FE  
 CL  
 MT  
 AT  
 PD  
 FA  
 RA  
 BR  
 ST  
 BF  
 HA

EL

## WIPER AND WASHER

### Wiper and Washer Adjustment (Cont'd)

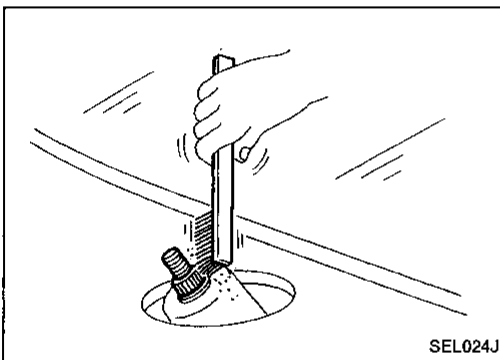
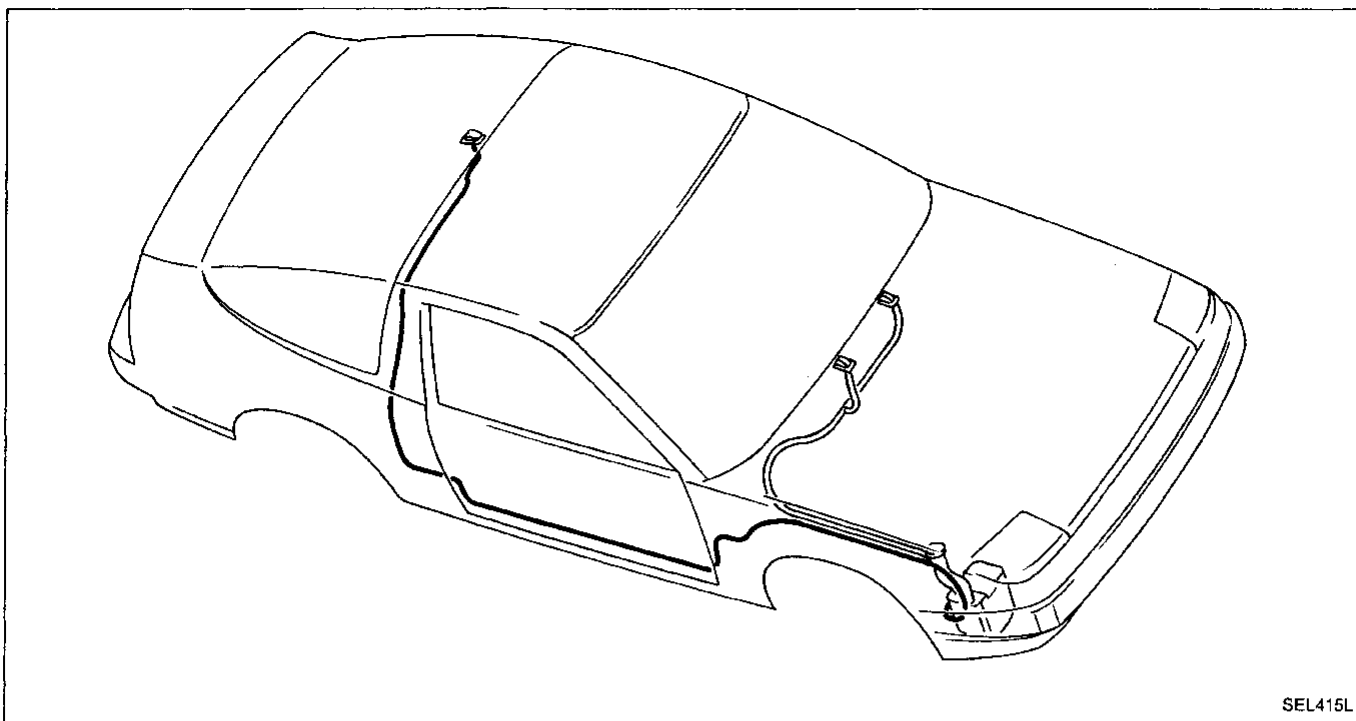

- Before reinstalling wiper arm, clean up the pivot area as illustrated. This will reduce possibility of wiper arm looseness.

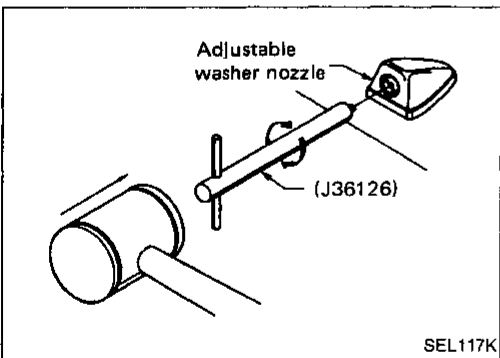

### Washer Nozzle Adjustment

- Using Tool (J36126), adjust windshield washer nozzle to correct its spray pattern.

#### Special Service Tool:

Tool number: J36126

Tool name: Washer nozzle adjusting tool

Before attempting to turn the nozzle, gently tap the end of the tool to free the nozzle.

This will prevent "rounding out" the small female square in the center of the nozzle.

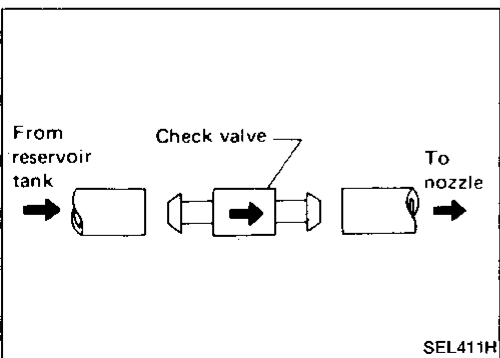

### Check Valve

- A check valve is provided in the washer fluid line. Be careful not to connect check valve to washer tube in the wrong direction.

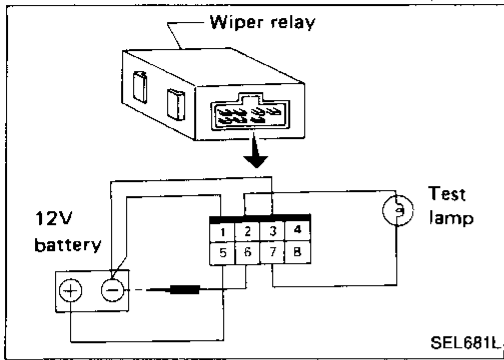

## Wiper Amplifier Check

1. Connect as shown in the figure at left.
2. If test lamp comes on when connected to terminal ⑥ and battery ground, wiper relay is normal.

GI

MA

EM

LC

EF &  
EC

FE

CL

MT

AT

PD

FA

RA

BR

ST

BF

HA

EL

# HORN, CIGARETTE LIGHTER AND CLOCK

## Wiring Diagram

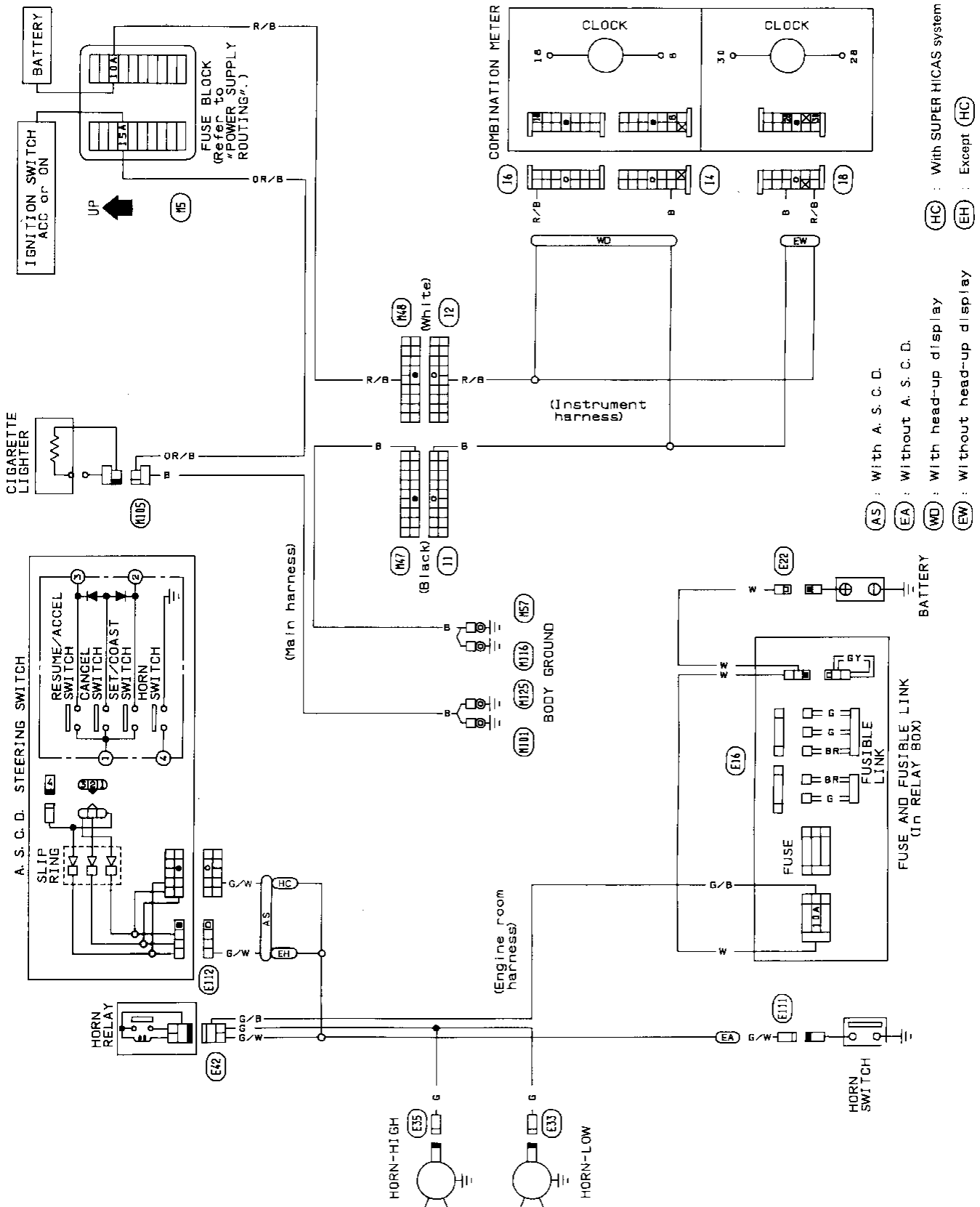



# REAR WINDOW DEFOGGER

## Wiring Diagram

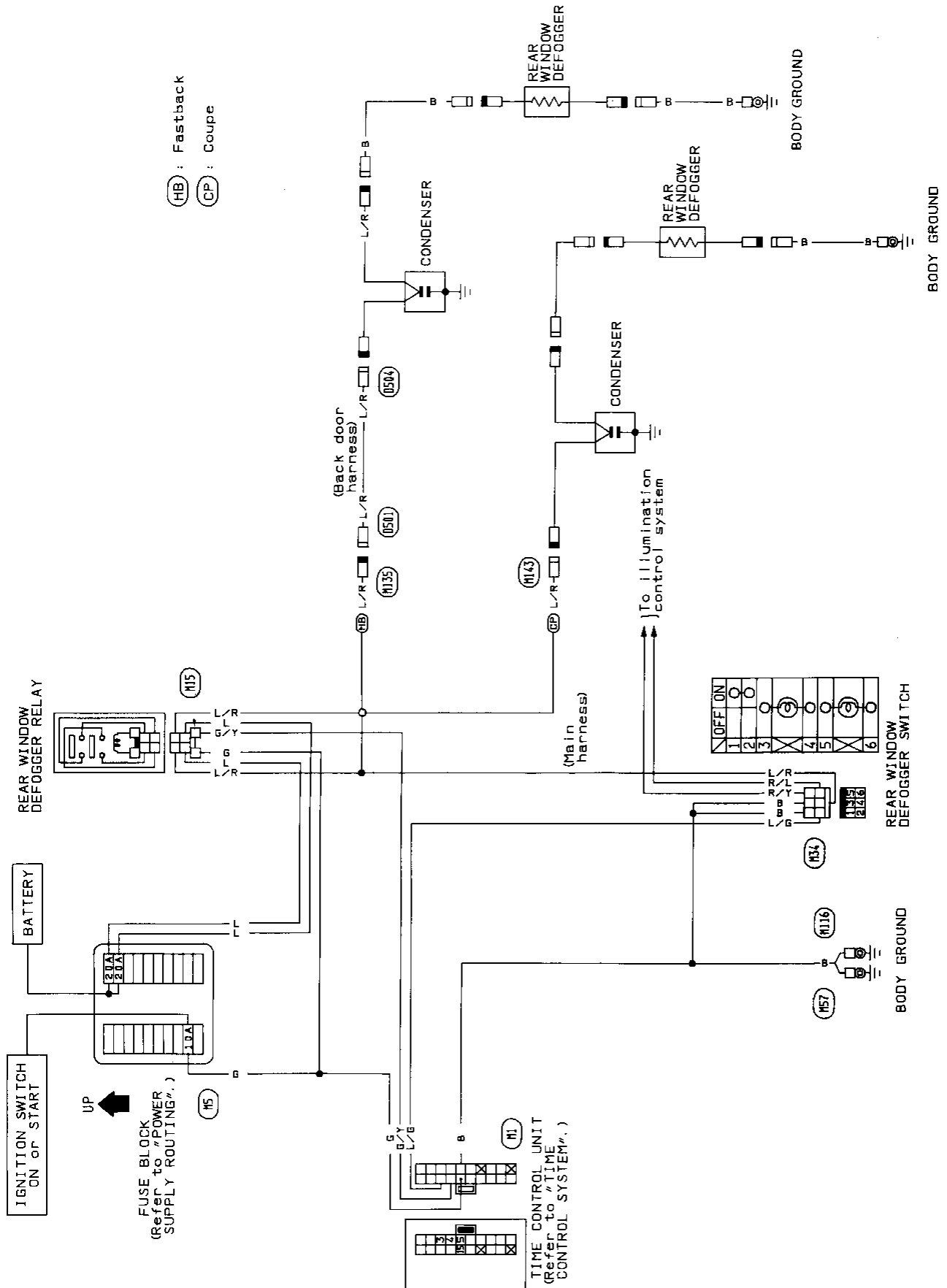

GI  
 MA  
 EM  
 LC  
 EF &  
 EC  
 FE  
 CL  
 MT  
 AT  
 PD  
 FA  
 RA  
 BR  
 ST  
 BF  
 HA  
**EL**

# REAR WINDOW DEFOGGER

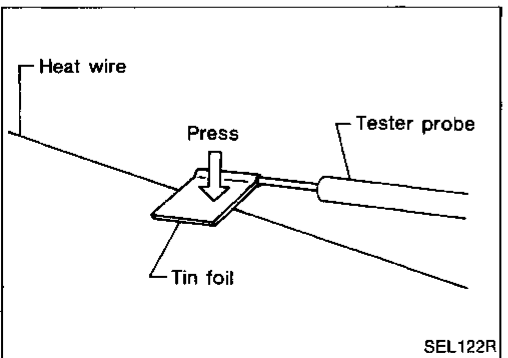
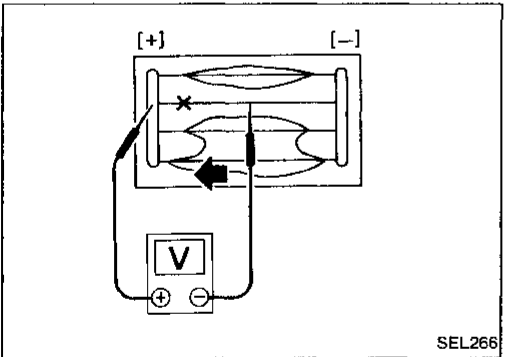
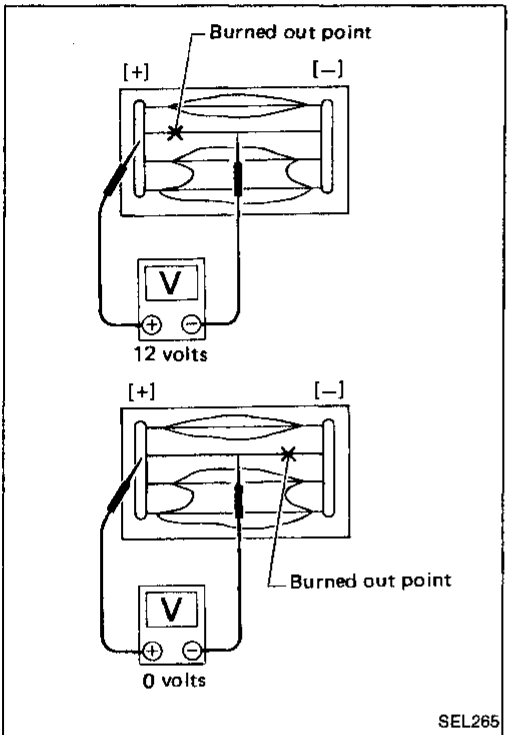
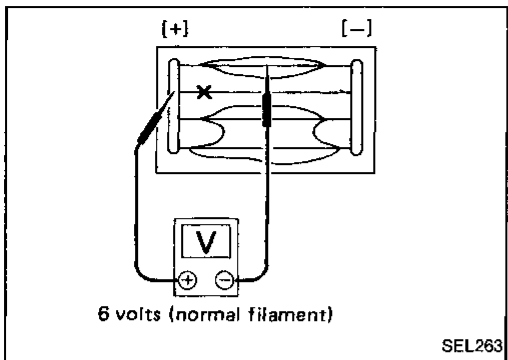

## Filament Check

1. Attach probe circuit tester (in volt range) to middle portion of each filament.

2. If a filament is burned out, circuit tester registers 0 or 12 volts.

3. To locate burned out point, move probe to left and right along filament to determine point where tester needle swings abruptly.

● When measuring voltage, wind a piece of tin foil around the top of the negative probe and press the foil against the wire with your finger as shown.

# REAR WINDOW DEFOGGER

## Filament Repair

### REPAIR EQUIPMENT

1. Conductive silver composition (Dupont No. 4817 or equivalent)
2. Ruler 30 cm (11.8 in) long
3. Drawing pen
4. Heat gun
5. Alcohol
6. Cloth

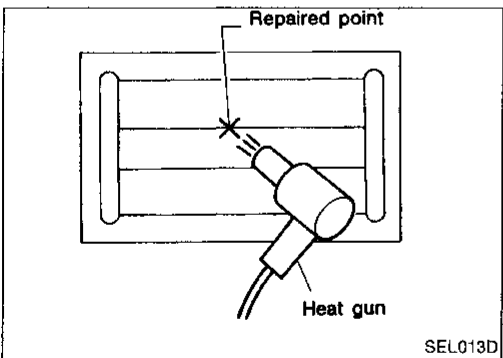
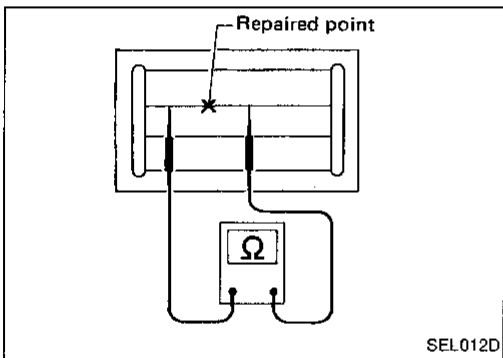
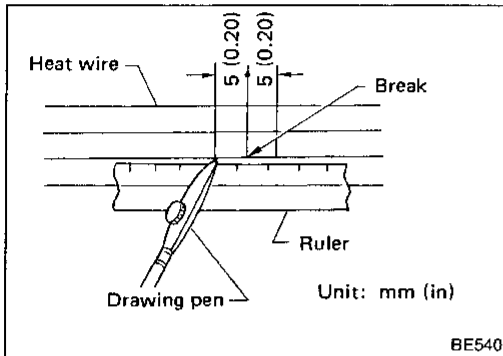

### REPAIRING PROCEDURE

1. Wipe broken heat wire and its surrounding area clean with a cloth dampened in alcohol.
2. Apply a small amount of conductive silver composition to tip of drawing pen.

**Shake silver composition container before use.**

3. Place ruler on glass along broken line. Deposit conductive silver composition on break with drawing pen. Slightly overlap existing heat wire on both sides [preferably 5 mm (0.20 in)] of the break.

4. After repair has been completed, check repaired wire for continuity. This check should be conducted 10 minutes after silver composition is deposited.

**Do not touch repaired area while test is being conducted.**

5. Apply a constant stream of hot air directly to the repaired area for approximately 20 minutes with a heat gun. A minimum distance of 3 cm (1.2 in) should be kept between repaired area and hot air outlet. If a heat gun is not available, let the repaired area dry for 24 hours.

GI

MA

EM

LC

EF &  
EC

FE

CL

MT

AT

PD

FA

RA

BR

ST

BF

HA

EL

## Audio/Wiring Diagram

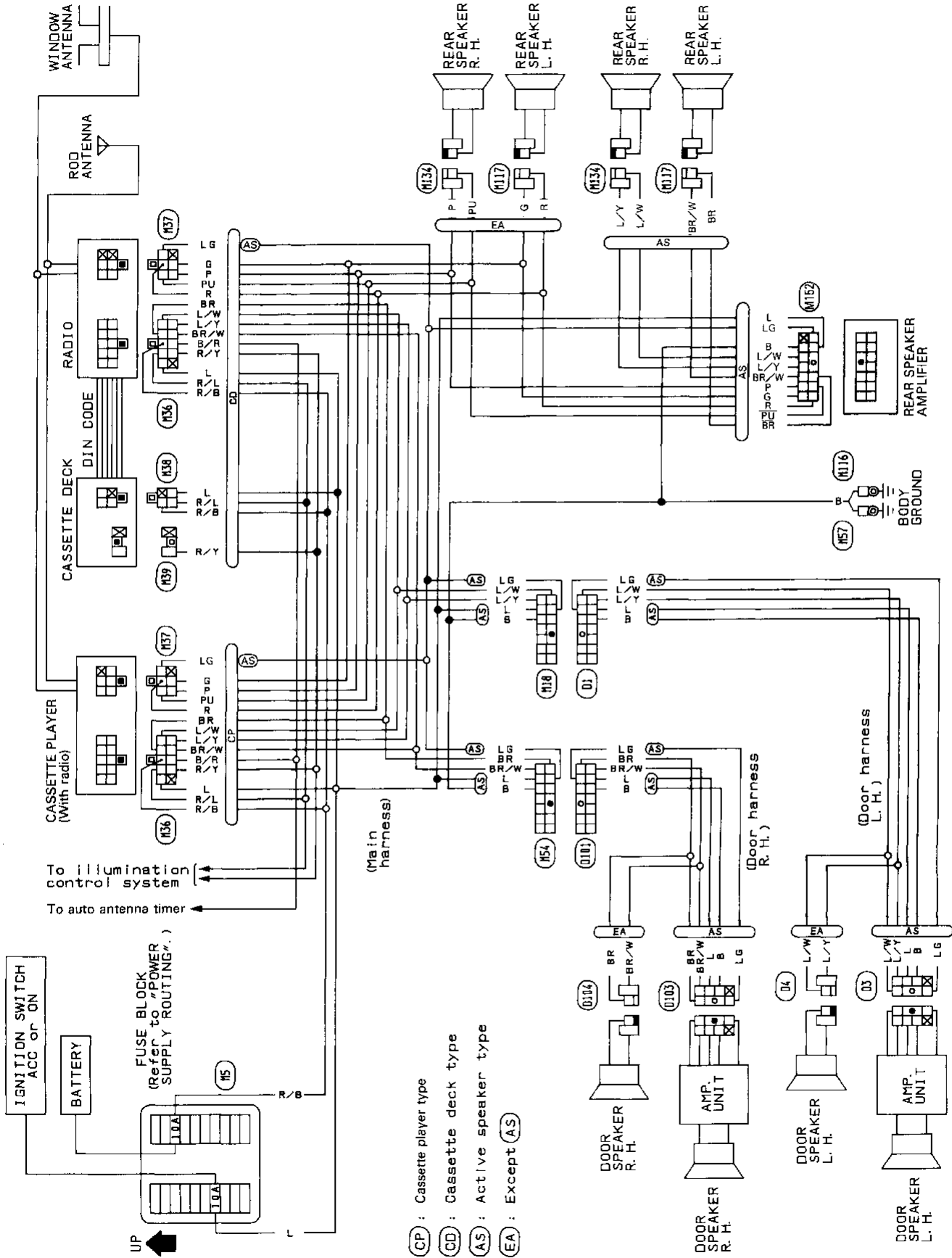

# AUDIO AND POWER ANTENNA

## Power Antenna/Wiring Diagram

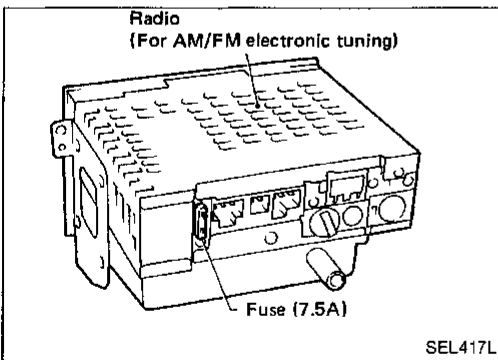
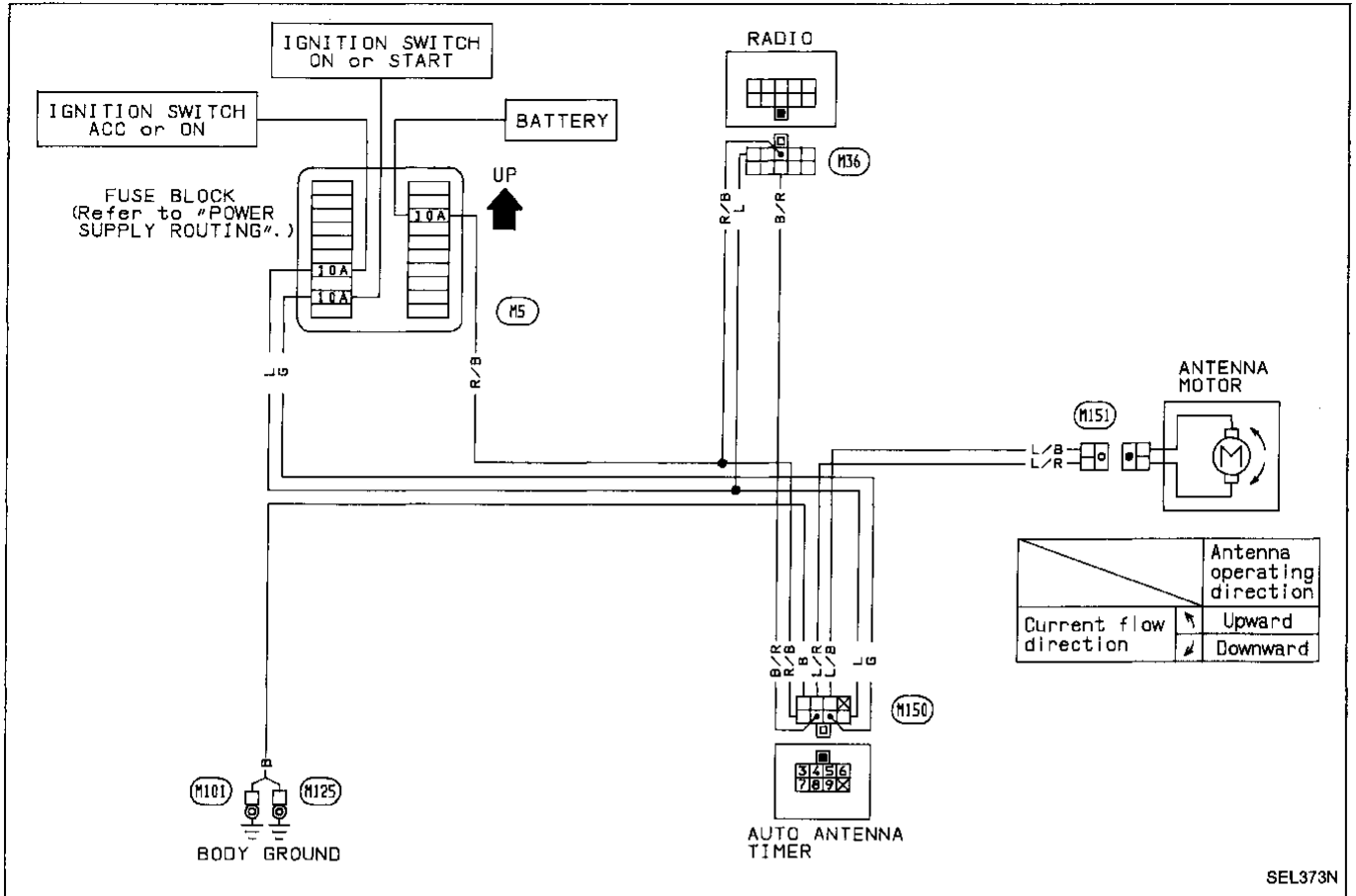

## Radio Fuse Check

GI  
MA  
EM  
LC  
EF &  
EC  
FE  
CL  
MT  
AT  
PD  
FA  
RA  
BR  
ST  
BF  
HA  
EL

## Location of Antenna

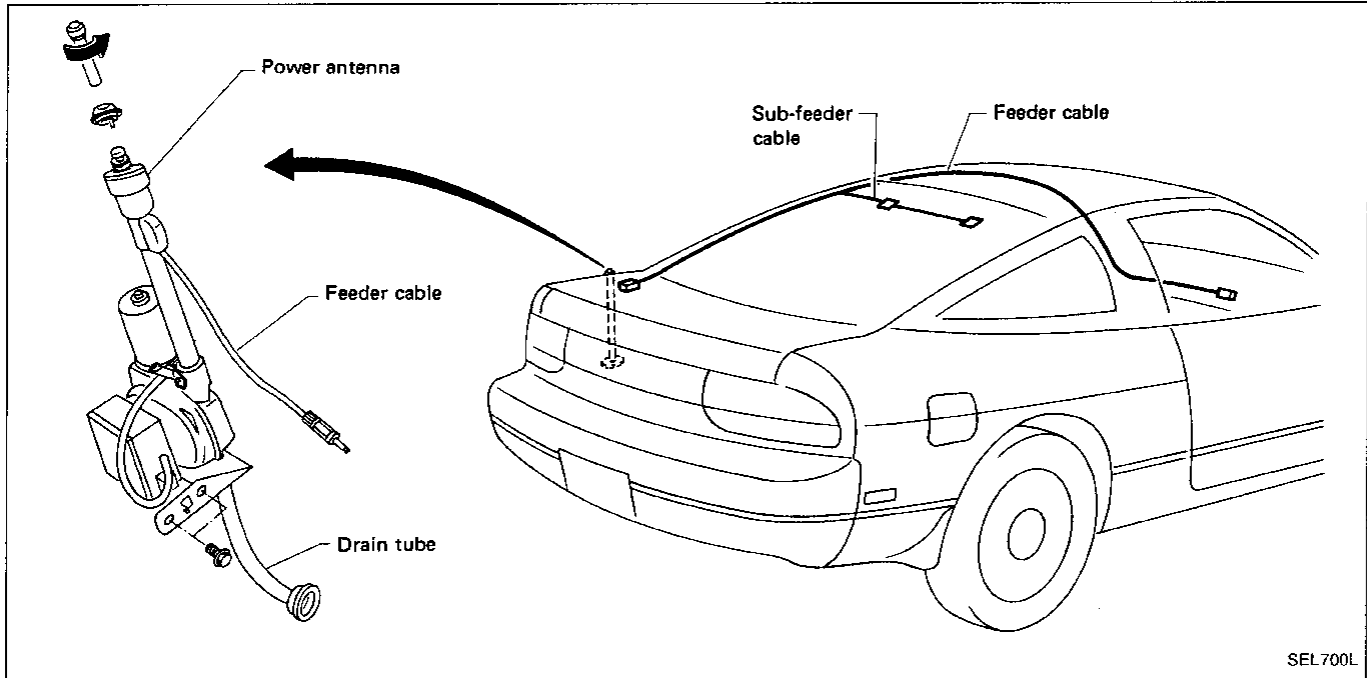

SEL700L

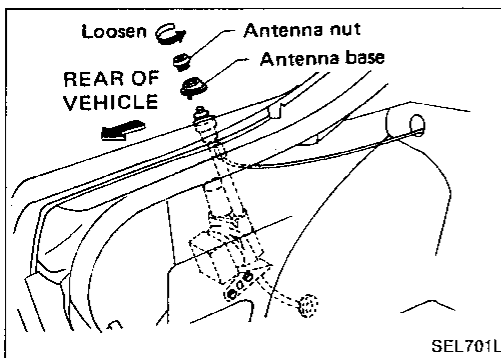

SEL701L

## Antenna Rod Replacement

### REMOVAL

1. Remove antenna nut and antenna base.

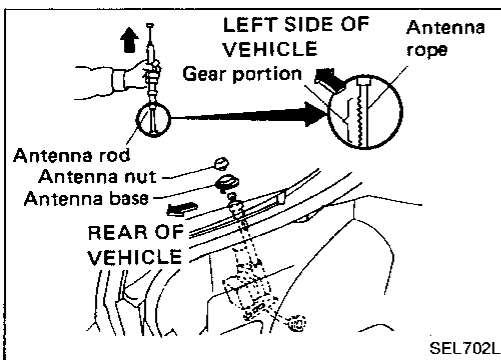

SEL702L

2. Withdraw antenna rod while raising it by operating antenna motor.  
(Turn radio switch from "OFF" to "ON" to operate antenna motor.)

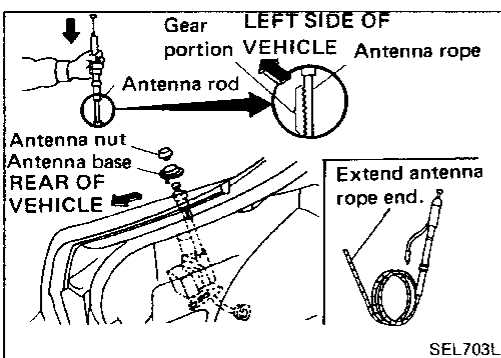

SEL703L

### INSTALLATION

1. Lower antenna rod by operating antenna motor.  
(Turn radio switch from "ON" to "OFF".)
2. Insert gear section of antenna rope into place with it facing toward antenna motor.
3. As soon as antenna rope is wound on antenna motor, stop antenna motor. Insert antenna rod lower end into antenna motor pipe.

## AUDIO AND POWER ANTENNA

### Antenna Rod Replacement (Cont'd)

- Retract antenna rod completely by operating antenna motor.  
(If the antenna motor stops before antenna has fully retracted, turn radio switch to "ON" and immediately turn to "OFF" again.)
- Install antenna nut and base.

GI

MA

EM

LC

EF &  
EC

FE

CL

MT

AT

PD

FA

RA

BR

ST

BF

HA

EL

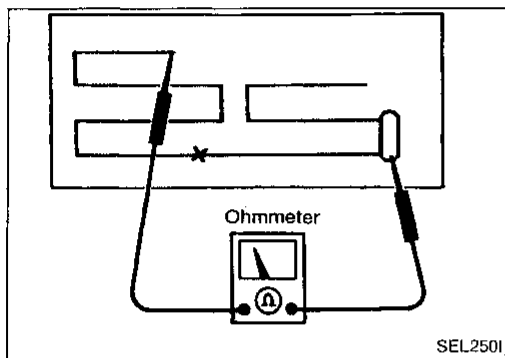

### Window Antenna Repair

#### ELEMENT CHECK

- Attach probe circuit tester (in ohm range) to antenna terminal on each side.

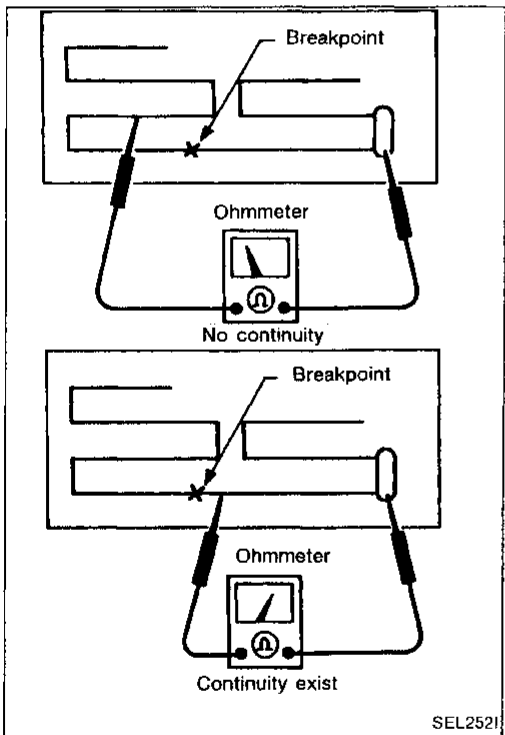

- If an element is broken, no continuity will exist.

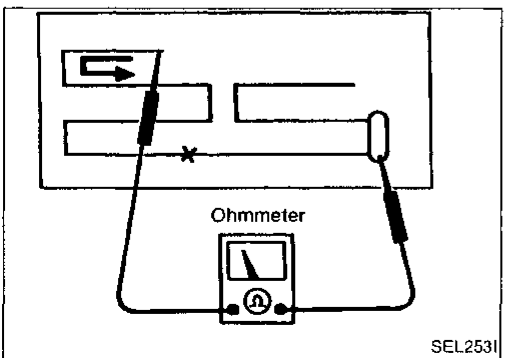

- To locate broken point, move probe to left and right along element to determine point where tester needle swings abruptly.
- Refer to REAR WINDOW DEFOGGER "Filament Repair" for Element Repair.

# AUTOMATIC SPEED CONTROL DEVICE (A.S.C.D.)

## Wiring Diagram

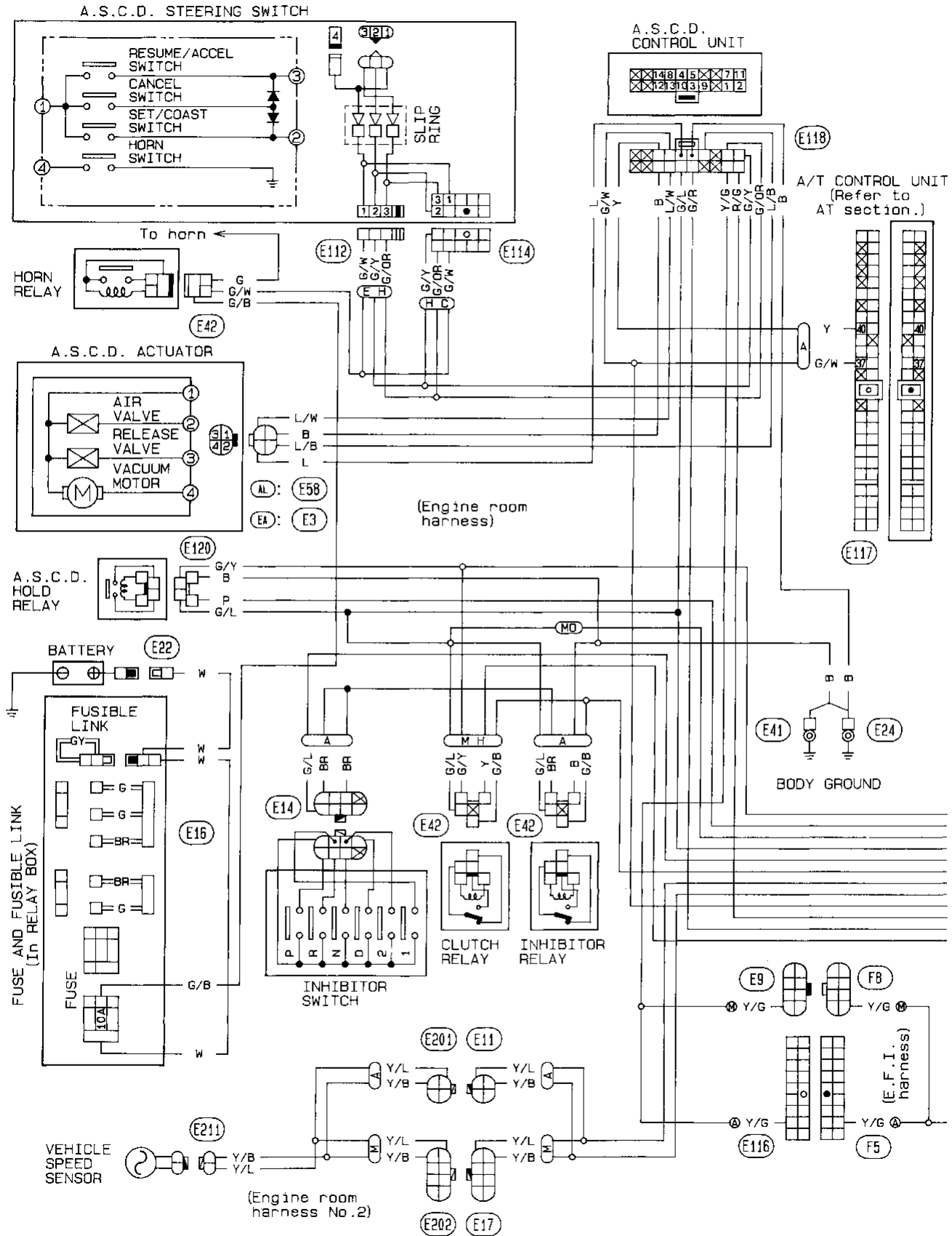



# AUTOMATIC SPEED CONTROL DEVICE (A.S.C.D.)

## Wiring Diagram (Cont'd)

\*1: Connected to head-up display control unit

HEAD-UP DISPLAY CONTROL UNIT

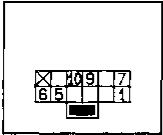

COMBINATION UNIT

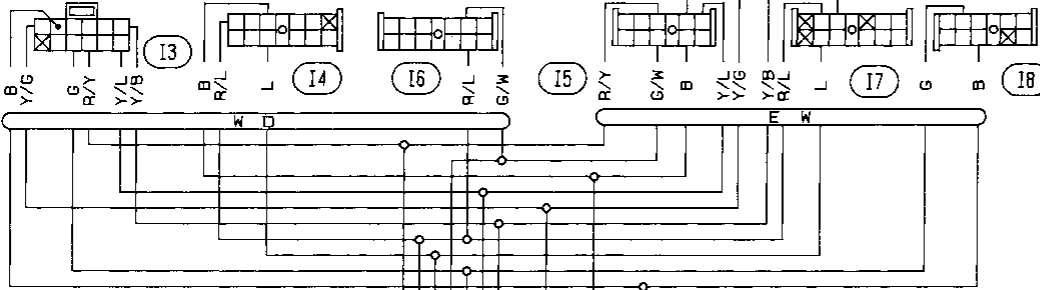
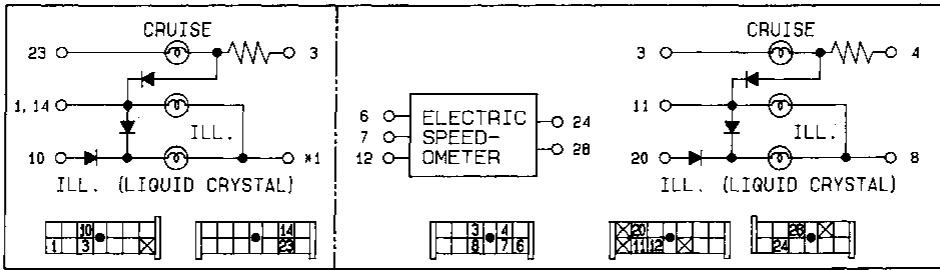

To illumination control system

A.S.C.D. MAIN SWITCH

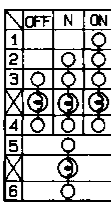

(E101)

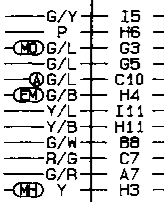

S.M.J. (Refer to last page <Foldout page>.)

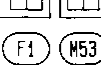
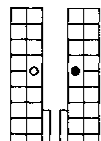

M116

M57

BODY GROUND

HICAS CLUTCH SWITCH

STOP LAMP SWITCH

A.S.C.D. CANCEL SWITCH

A.S.C.D. CLUTCH SWITCH

IGNITION SWITCH ACC or ON

IGNITION SWITCH ON or START

BATTERY

FUSE BLOCK (Refer to "POWER SUPPLY ROUTING" in EL section.)

- (A) : A/T model
- (M) : M/T model
- (WD) : With head-up display
- (EW) : Without head-up display
- (AL) : With anti-lock braking system
- (EA) : Without anti-lock braking system
- (HC) : With SUPER HICAS system
- (EH) : Except (HC)
- (MH) : M/T model with SUPER HICAS system
- (MD) : M/T model without SUPER HICAS system
- (EM) : Except (MD)

GI  
MA  
EM  
LC  
EF & EC  
FE  
CL  
MT  
AT  
PD  
FA  
RA  
BR  
ST  
BF  
HA

EL

# AUTOMATIC SPEED CONTROL DEVICE (A.S.C.D.)

## Schematic

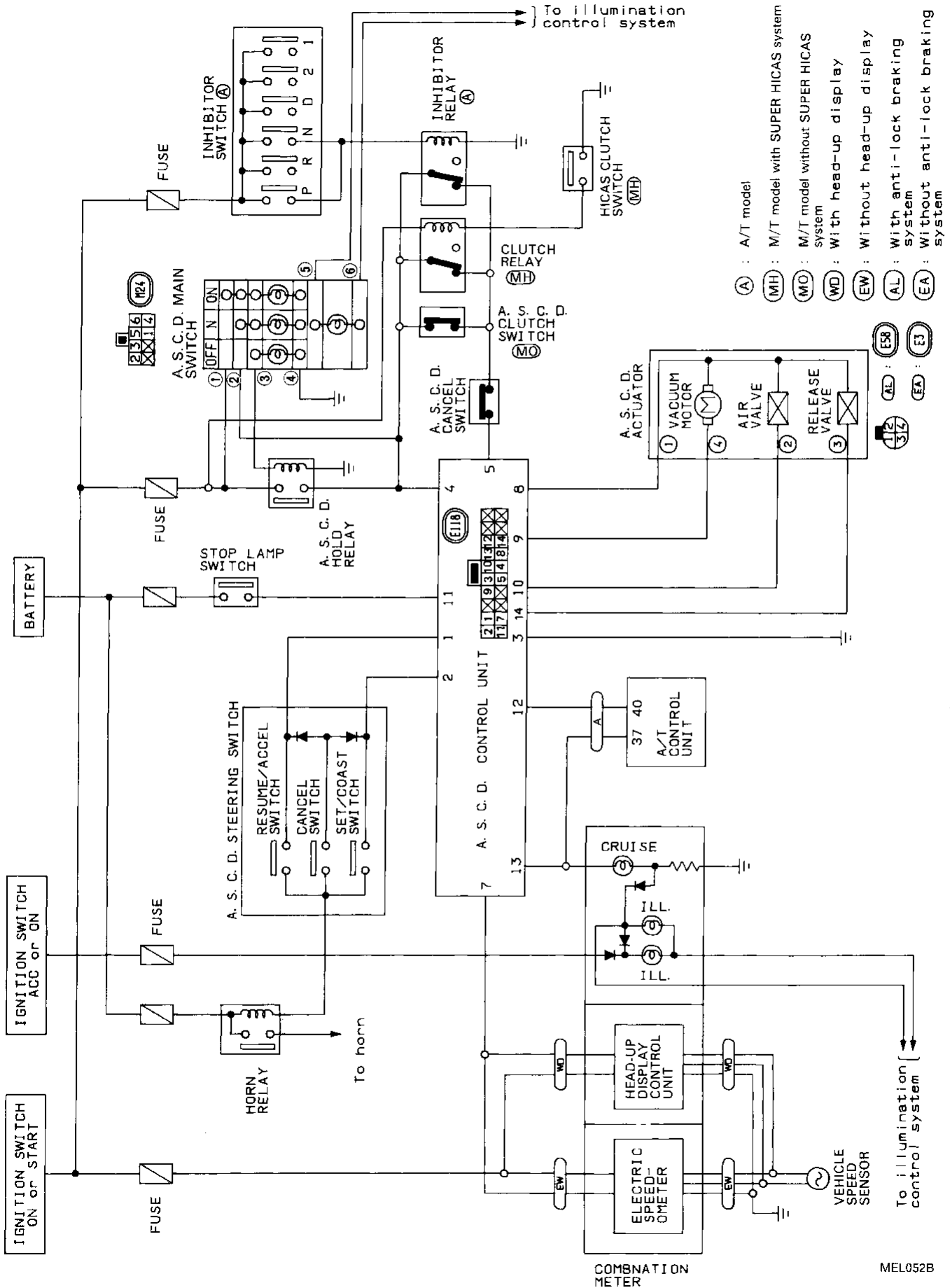

# AUTOMATIC SPEED CONTROL DEVICE (A.S.C.D.)

## Trouble Diagnoses

### SYMPTOM CHART

PROCEDURE	Diagnostic Procedure								Electrical Components Inspection							
REFERENCE PAGE	EL-76	EL-78	EL-78	EL-78	EL-79	EL-80	EL-81	EL-82	EL-83	EL-84	EL-85	EL-85	EL-85	EL-85	EL-86	EL-86
SYMPTOM	Diagnostic Procedure 1	Diagnostic Procedure 2	Diagnostic Procedure 3	Diagnostic Procedure 4	Diagnostic Procedure 5	Diagnostic Procedure 6	Diagnostic Procedure 7	Diagnostic Procedure 8	A.S.C.D. wire adjustment	A.S.C.D. actuator/A.S.C.D. pump	A.S.C.D. main switch	A.S.C.D. steering switch	A.S.C.D. cancel switch and stop lamp switch	A.S.C.D. clutch switch (For M/T models)	Inhibitor switch (For A/T models)	Speed sensor
A.S.C.D. control unit cannot be set properly.	<input type="checkbox"/>									<input type="checkbox"/>	<input type="checkbox"/>	<input type="checkbox"/>	<input type="checkbox"/>	<input type="checkbox"/>	<input type="checkbox"/>	<input type="checkbox"/>
Engine hunts		<input type="checkbox"/>							<input type="checkbox"/>	<input type="checkbox"/>						
Large difference between set speed and actual vehicle speed.			<input type="checkbox"/>						<input type="checkbox"/>	<input type="checkbox"/>						
Deceleration is greatest immediately after A.S.C.D. has been set.				<input type="checkbox"/>					<input type="checkbox"/>	<input type="checkbox"/>						
ACCEL switch will not operate.	<input type="checkbox"/>				<input type="checkbox"/>							<input type="checkbox"/>				
RESUME switch will not operate.	<input type="checkbox"/>					<input type="checkbox"/>						<input type="checkbox"/>	<input type="checkbox"/>	<input type="checkbox"/>		
Set speed cannot be cancelled.							<input type="checkbox"/>		<input type="checkbox"/>	<input type="checkbox"/>			<input type="checkbox"/>	<input type="checkbox"/>		
"CRUISE" indicator lamp blinks.								<input type="checkbox"/>		<input type="checkbox"/>		<input type="checkbox"/>	<input type="checkbox"/>			

GI  
 MA  
 EM  
 LC  
 EF &  
 EC  
 FE  
 CL  
 MT  
 AT  
 PD  
 FA  
 RA  
 BR  
 ST  
 BF  
 HA

EL

# AUTOMATIC SPEED CONTROL DEVICE (A.S.C.D.)

## Trouble Diagnoses (Cont'd)

### DIAGNOSTIC PROCEDURE 1

**SYMPTOM: A.S.C.D. control cannot be set.**

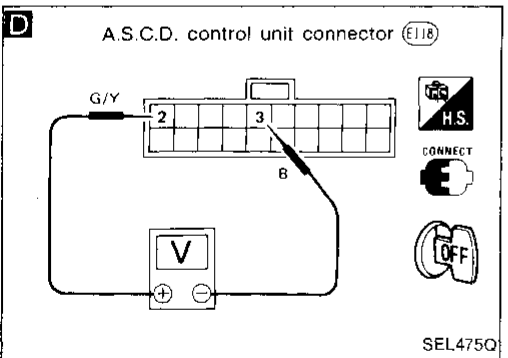
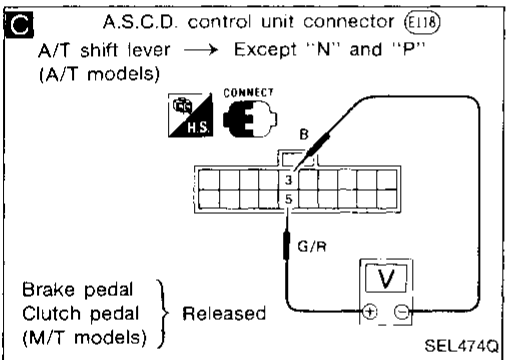
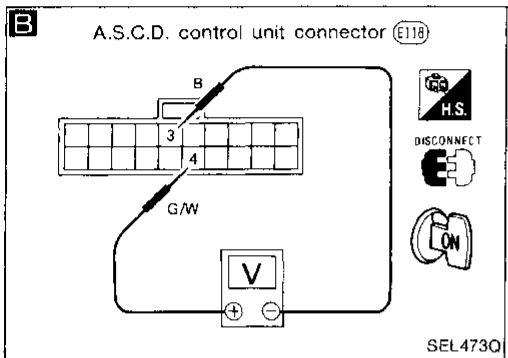
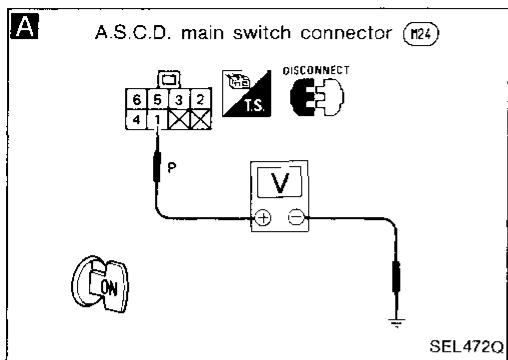

Turn A.S.C.D. main switch "OFF" and "ON" to make sure indicator illuminates.

**A**  
CHECK POWER SUPPLY FOR A.S.C.D. MAIN SWITCH.  
1. Disconnect main switch harness connector.  
2. Do approx. 12 volts exist between main switch harness terminal ① and body ground?

No  
Check fuse and harness.

Yes  
CHECK A.S.C.D. MAIN SWITCH. Refer to "Electrical Components Inspection". CHECK A.S.C.D. HOLD RELAY.

**B**  
CHECK POWER SUPPLY CIRCUIT FOR A.S.C.D. CONTROL UNIT.  
1. Turn A.S.C.D. main switch "ON".  
2. Check voltage between control unit harness terminals ④ and ③.  
**Battery voltage should exist.**

N.G. Check continuity between control unit harness terminal ④ and A.S.C.D. hold relay.

**C**  
CHECK CUT-OFF CIRCUIT FOR A.S.C.D. CONTROL UNIT.  
Check voltage between control unit harness terminals ⑤ and ③.  
**Battery voltage should exist.**

N.G. CHECK A.S.C.D. CANCEL SWITCH, A.S.C.D. CLUTCH SWITCH (M/T models) AND INHIBITOR SWITCH (A/T models). Refer to "Electrical Components Inspection". CHECK INHIBITOR RELAY (A/T models).

**D**  
CHECK SET/COAST SWITCH CIRCUIT FOR A.S.C.D. CONTROL UNIT.  
1. Turn and keep on SET/COAST switch of A.S.C.D. combination (steering) switch.  
2. Check voltage between control unit harness terminals ② and ③.  
**Battery voltage should exist.**

N.G. Does horn work?  
No  
Check fuse and horn relay.

Yes  
CHECK A.S.C.D. COMBINATION (STEERING) SWITCH. Refer to "Electrical Components Inspection".

O.K.  
**A**  
(Next page)

# AUTOMATIC SPEED CONTROL DEVICE (A.S.C.D.)

## Trouble Diagnoses (Cont'd)

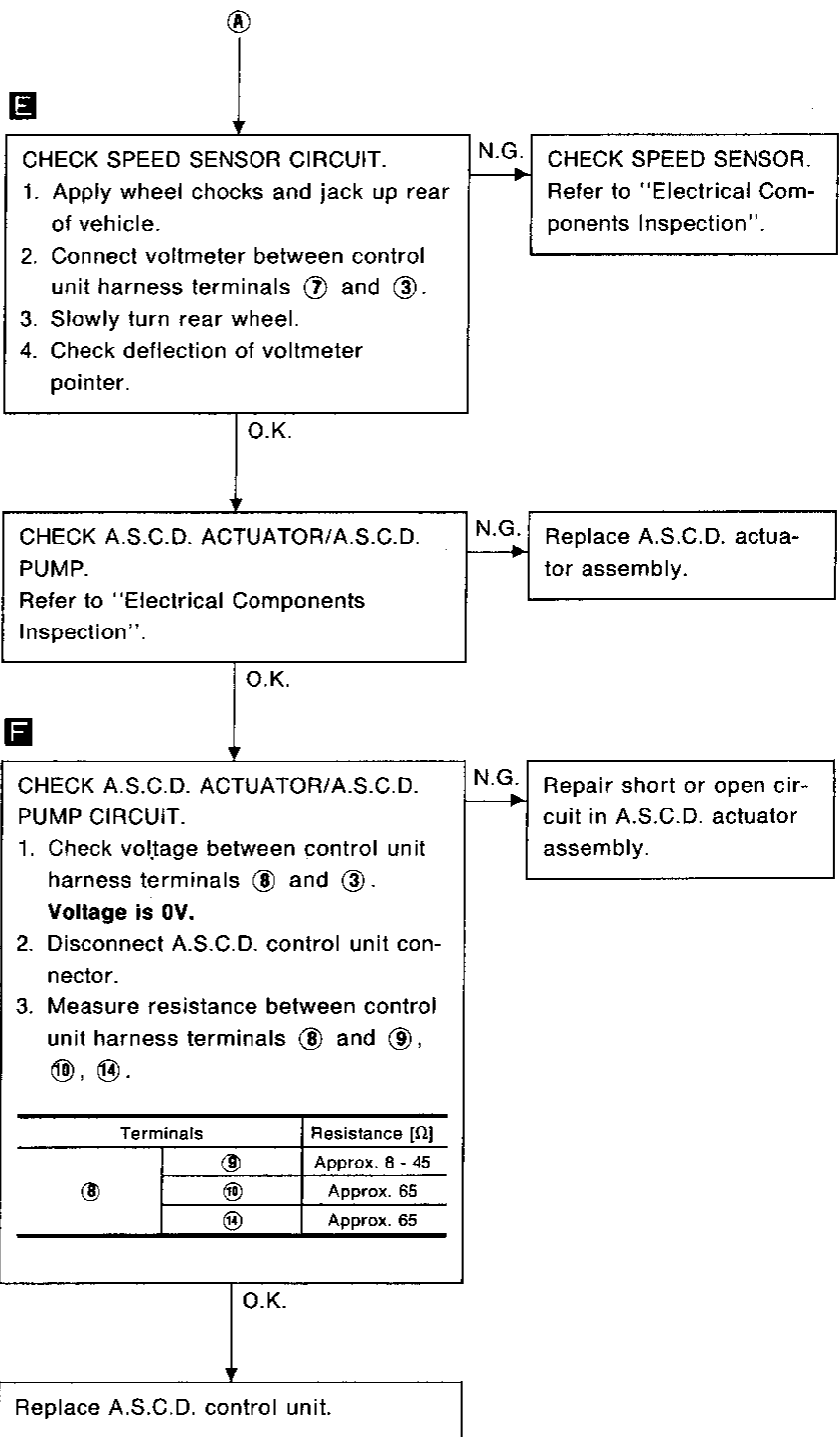
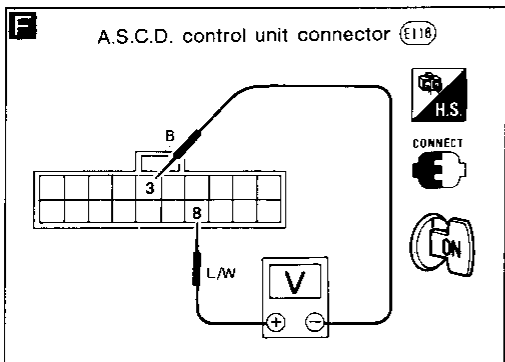
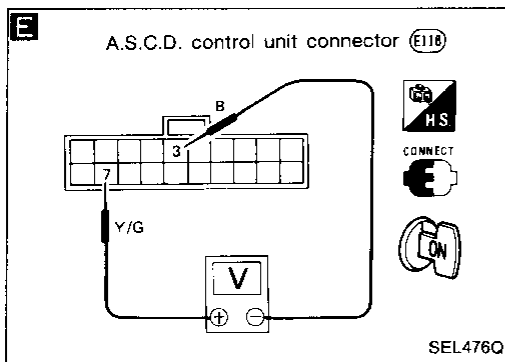

GI  
MA  
EM  
LC  
EF & EC  
FE  
CL  
MT  
AT  
PD  
FA  
RA  
BR  
ST  
BF  
HA

EL

# AUTOMATIC SPEED CONTROL DEVICE (A.S.C.D.)

## Trouble Diagnoses (Cont'd)

### DIAGNOSTIC PROCEDURE 2

**SYMPTOM: Engine hunts.**

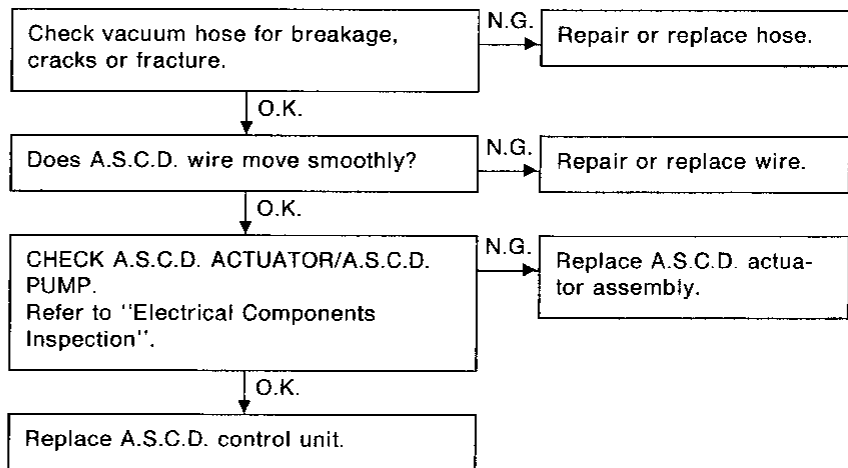

### DIAGNOSTIC PROCEDURE 3

**SYMPTOM: Large difference between set vehicle speed and actual speed.**

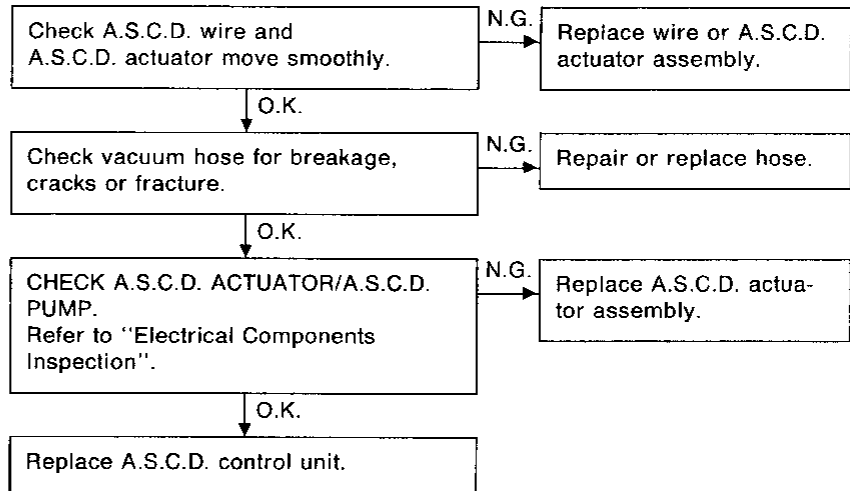

### DIAGNOSTIC PROCEDURE 4

**SYMPTOM: Deceleration is greatest immediately after A.S.C.D. has been set.**

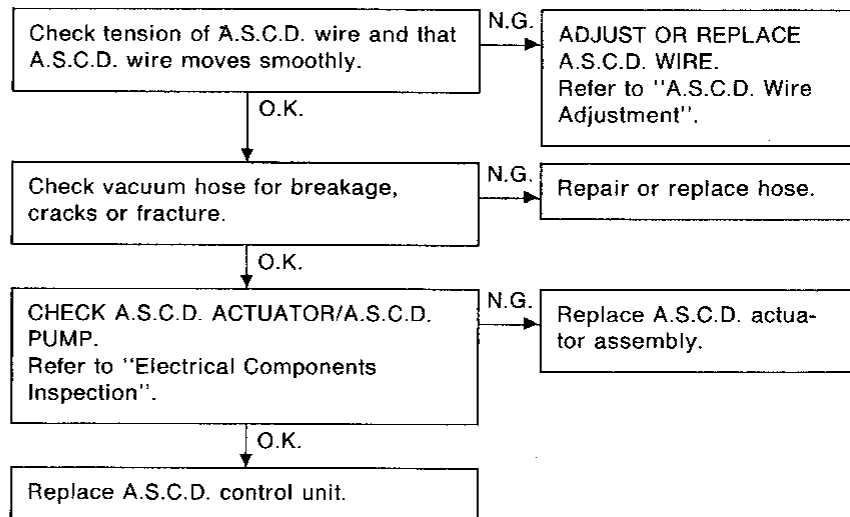

# AUTOMATIC SPEED CONTROL DEVICE (A.S.C.D.)

## Trouble Diagnoses (Cont'd)

### DIAGNOSTIC PROCEDURE 5

**SYMPTOM: ACCEL switch will not operate.**

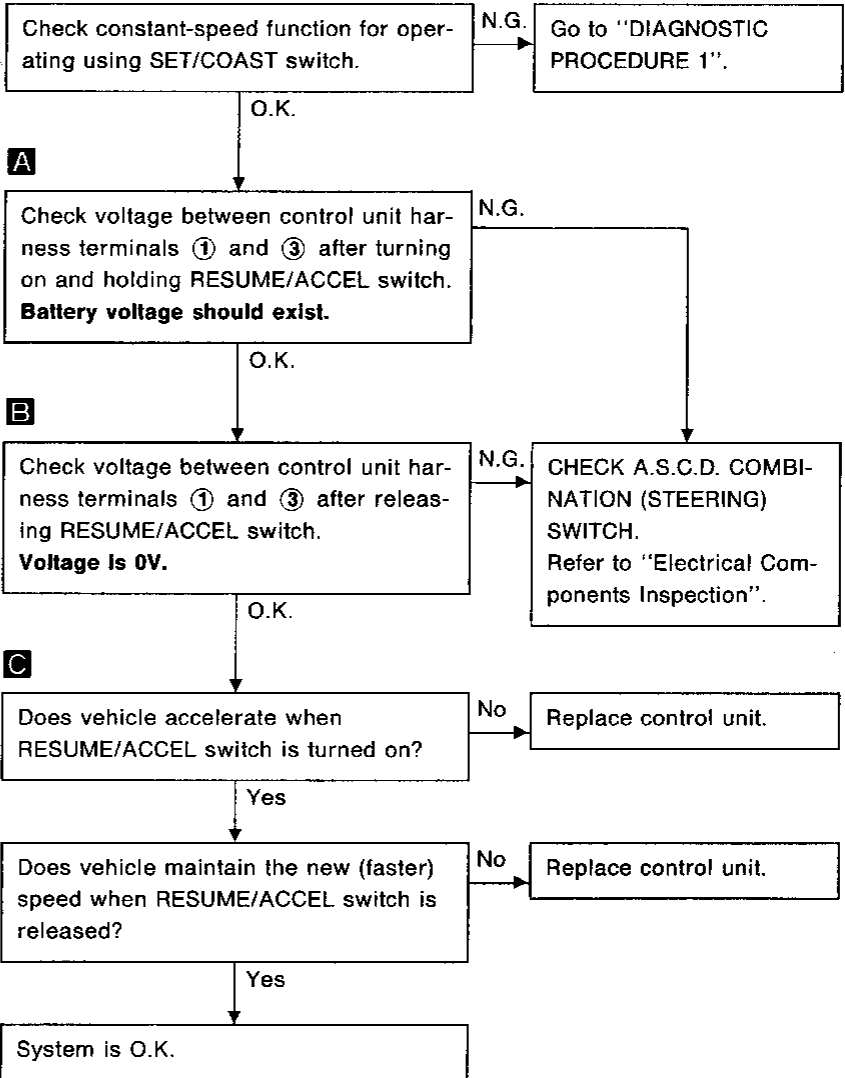
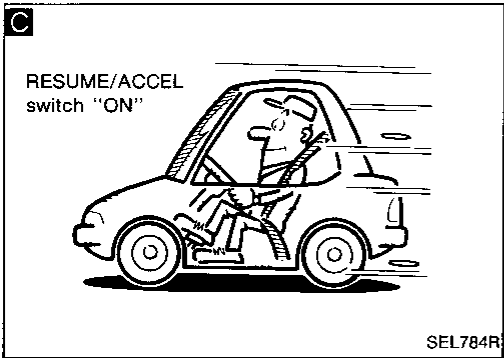
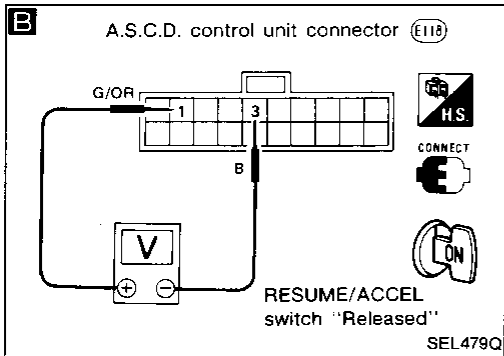
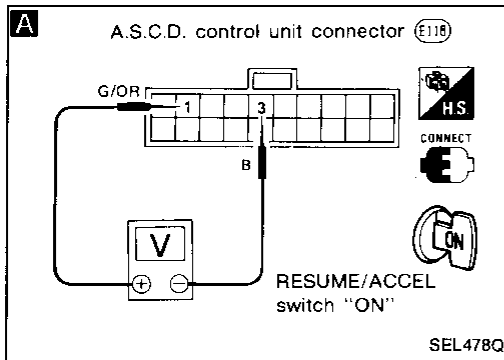

GI  
MA  
EM  
LC  
EF & EC  
FE  
CL  
MT  
AT  
PD  
FA  
RA  
BR  
ST  
BF  
HA

EL

# AUTOMATIC SPEED CONTROL DEVICE (A.S.C.D.)

## Trouble Diagnoses (Cont'd)

### DIAGNOSTIC PROCEDURE 6

**SYMPTOM: RESUME switch will not operate.**

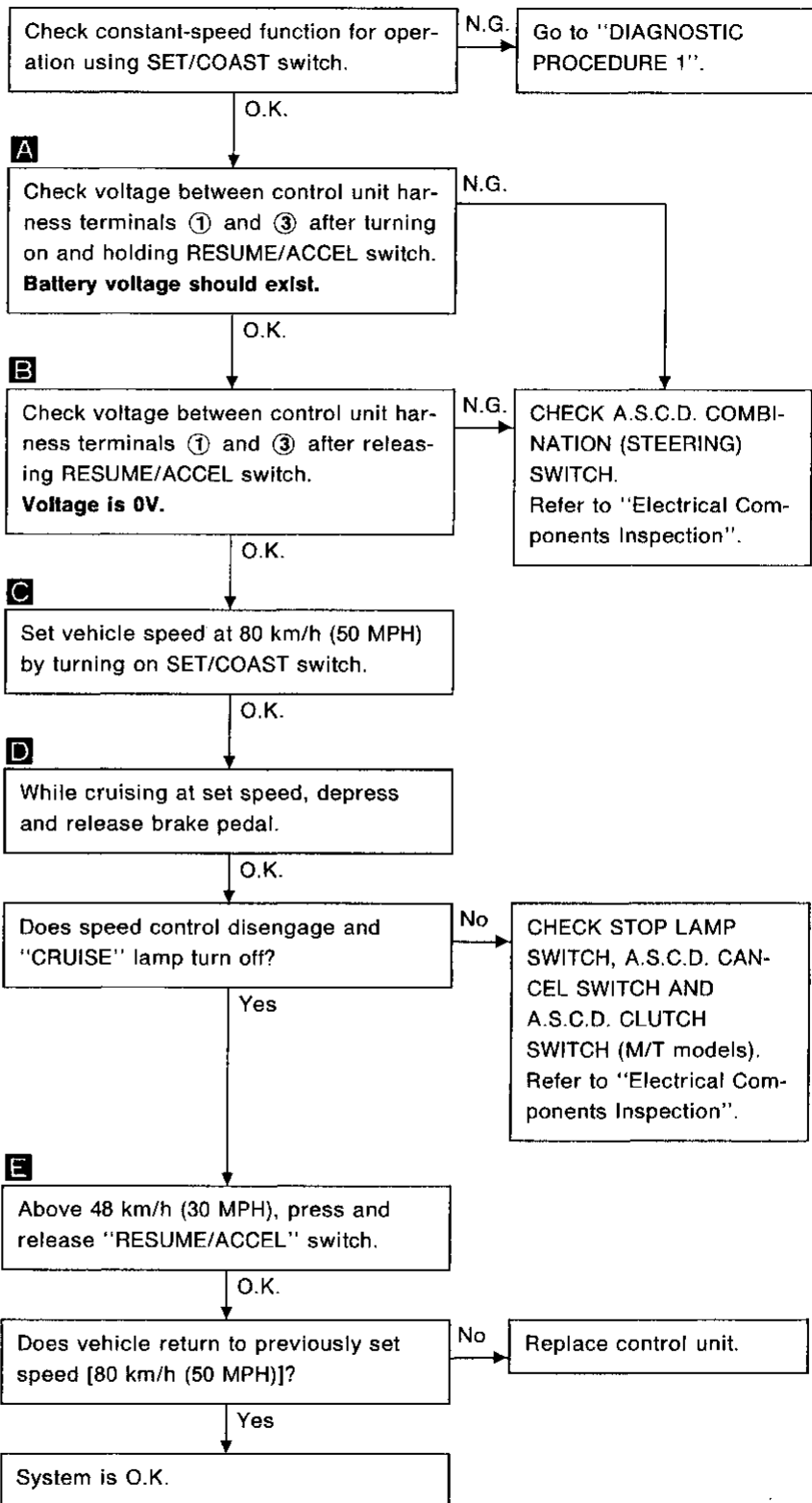
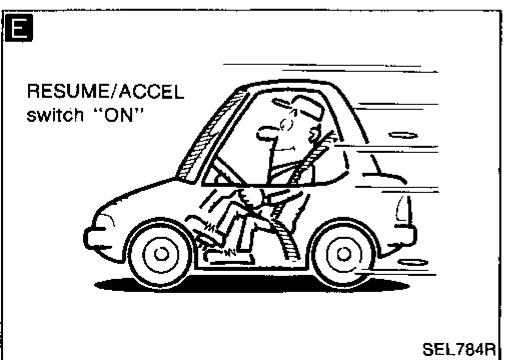
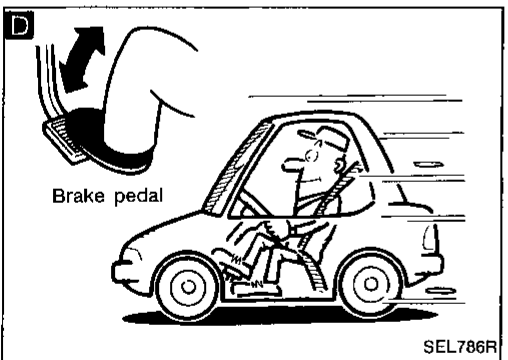
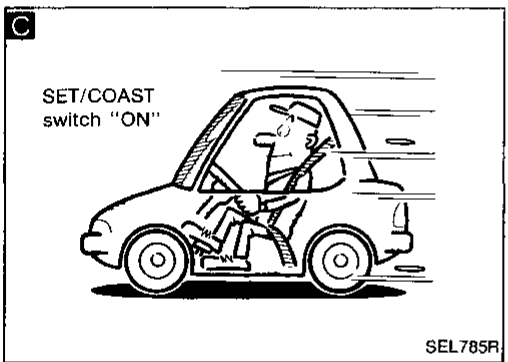
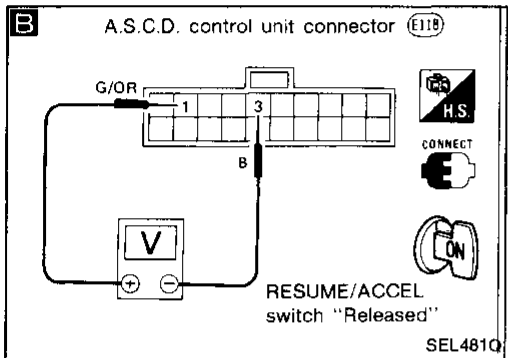
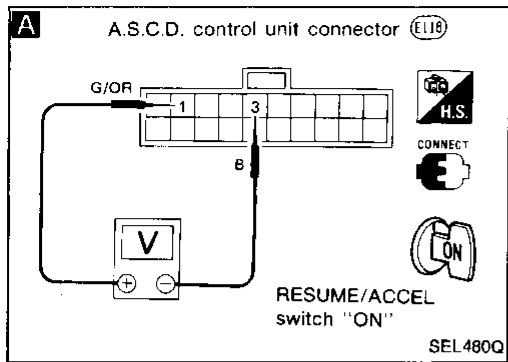



# AUTOMATIC SPEED CONTROL DEVICE (A.S.C.D.)

## Trouble Diagnoses (Cont'd)

### DIAGNOSTIC PROCEDURE 7

**SYMPTOM: Set speed cannot be cancelled.**

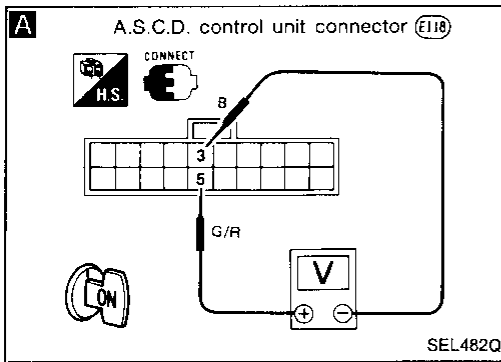

**A**

CHECK A.S.C.D. CANCEL, CLUTCH, INHIBITOR SWITCH CIRCUIT.

1. Turn A.S.C.D. main switch on.
2. Check voltage between control unit harness terminals ⑤ and ③.

N.G.

CHECK A.S.C.D. CANCEL, CLUTCH, and INHIBITOR SWITCH. Refer to "Electrical Components Inspection".

Conditions		Voltage [V]	
M/T	A.S.C.D. cancel switch	Depressed	0
		Released	Approx. 12
M/T	A.S.C.D. clutch switch	Depressed	0
		Released	Approx. 12
A/T	A/T shift lever position is at any position except N or P.		Approx. 12
	A/T shift lever position is at N or P.		0

O.K.

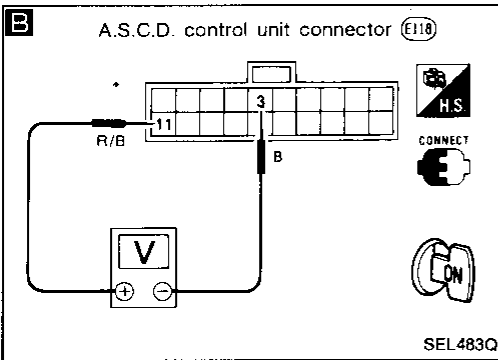

**B**

CHECK STOP LAMP SWITCH CIRCUIT. Check voltage between control unit harness terminals ⑪ and ③.

N.G.

CHECK STOP LAMP SWITCH. Refer to "Electrical Components Inspection".

Condition		Voltage [V]	
Stop lamp switch	Depressed	Approx. 12	
	Released	0	

O.K.

Check A.S.C.D. wire moves smoothly.

N.G.

Replace A.S.C.D. wire.

O.K.

CHECK A.S.C.D. ACTUATOR/A.S.C.D. PUMP. Refer to "Electrical Components Inspection".

N.G.

Replace A.S.C.D. actuator assembly.

O.K.

Replace A.S.C.D. control unit.

GI

MA

EM

LC

EF & EC

FE

CL

MT

AT

PD

FA

RA

BR

ST

BF

HA

EL

# AUTOMATIC SPEED CONTROL DEVICE (A.S.C.D.)

## Trouble Diagnoses (Cont'd)

### DIAGNOSTIC PROCEDURE 8

SYMPTOM: "CRUISE" indicator lamp blinks.

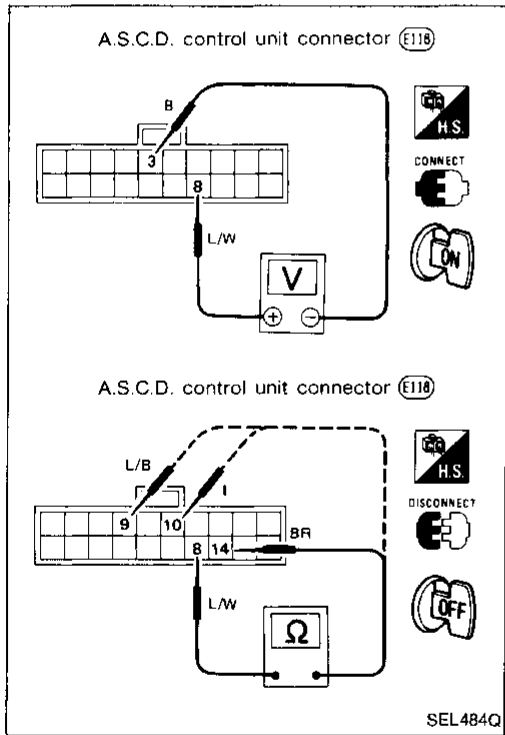
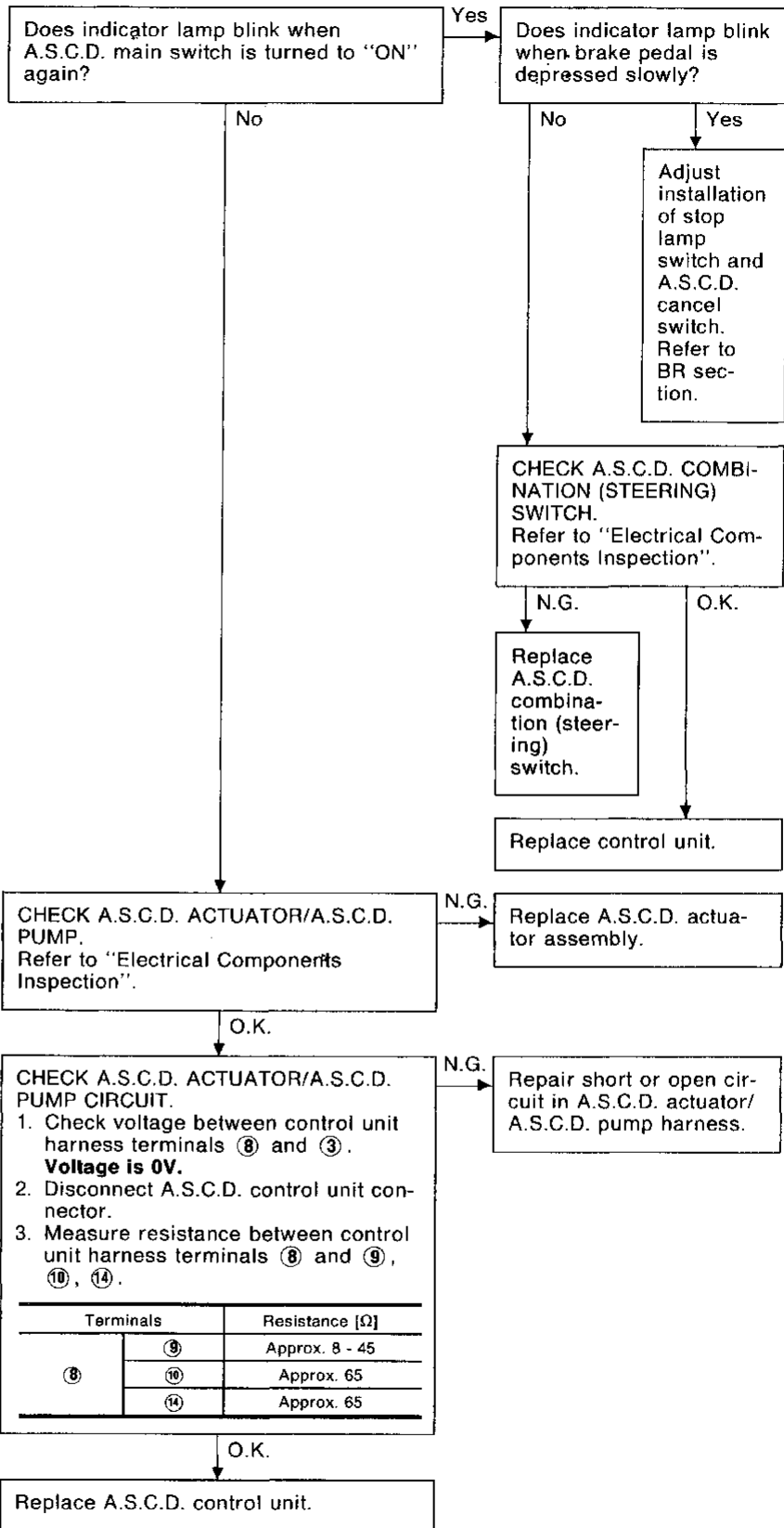

## A.S.C.D. Wire Adjustment

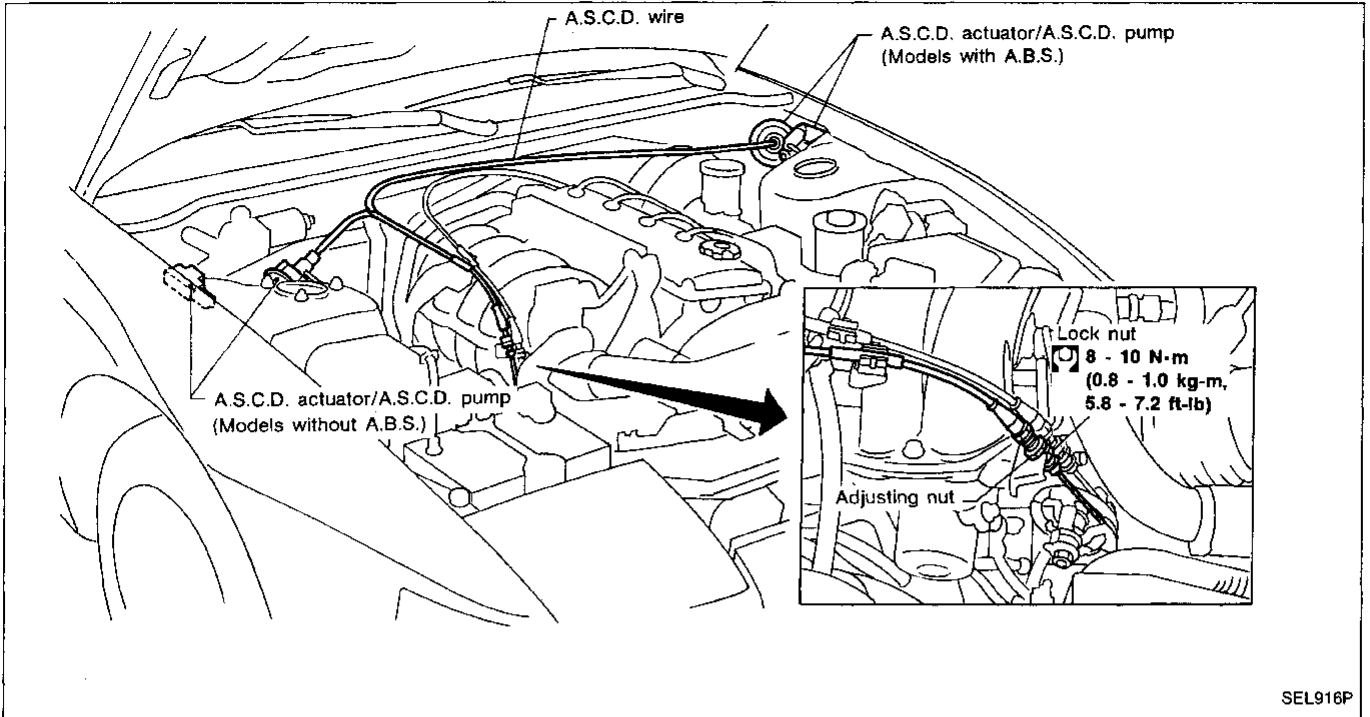

### CAUTION:

- Be careful not to twist A.S.C.D. wire when removing it.
  - Do not tense A.S.C.D. wire excessively during adjustment.
- After confirming that accelerator wire is properly adjusted, adjust the tension of A.S.C.D. wire in the following manner.
- (1) After adjusting the length of the accelerator wire, turn a securing nut by 1/2 to 1 turn from throttle open starting position to the wire loosening direction to fix. (Must be securing carried out to prevent response delay of operation of the A.S.C.D.)
  - (2) Securely tighten lock nut to hold adjusting nut in place.
- For A.S.C.D. cancel switch and clutch switch adjustment, refer to BR and CL sections.

GI

MA

EM

LC

EF &  
EC

FE

CL

SEL916P

MT

AT

PD

FA

RA

BR

ST

BF

HA

EL

# AUTOMATIC SPEED CONTROL DEVICE (A.S.C.D.)

## A.S.C.D. Wire Adjustment (Cont'd)

### ELECTRICAL COMPONENTS INSPECTION

#### A.S.C.D. actuator/A.S.C.D. pump

1. Disconnect A.S.C.D. actuator/A.S.C.D. pump connector.
2. Check A.S.C.D. actuator/A.S.C.D. pump operations as shown.

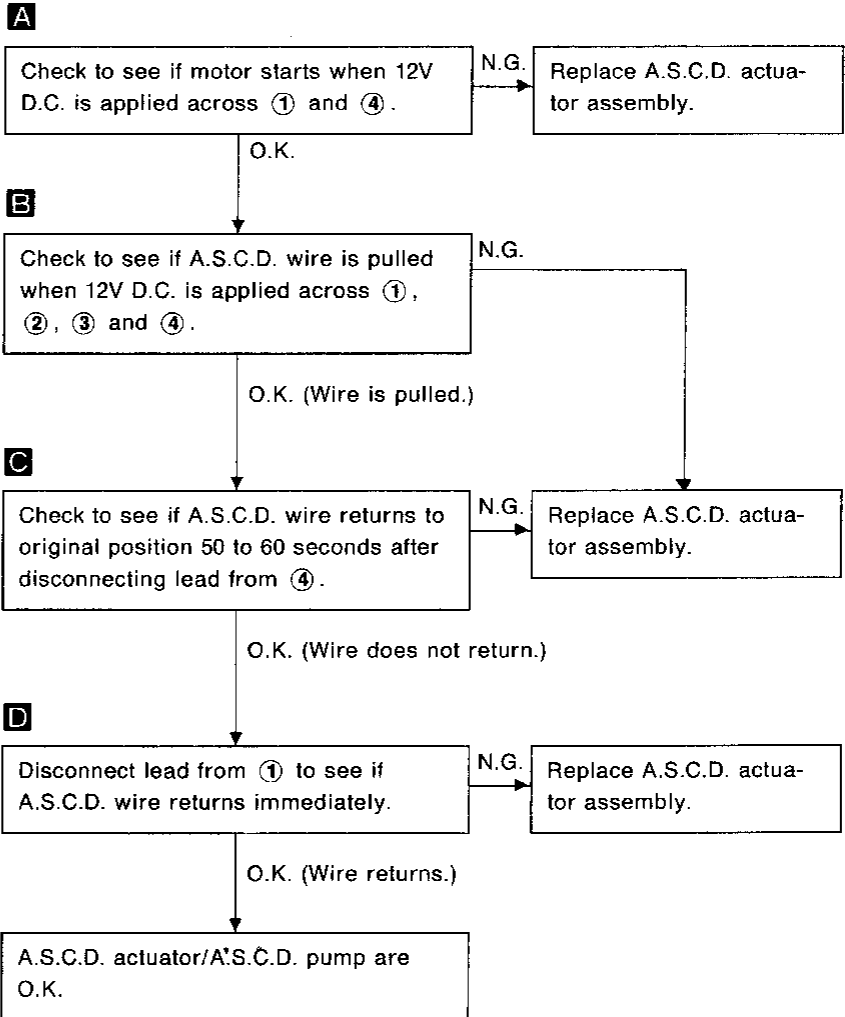
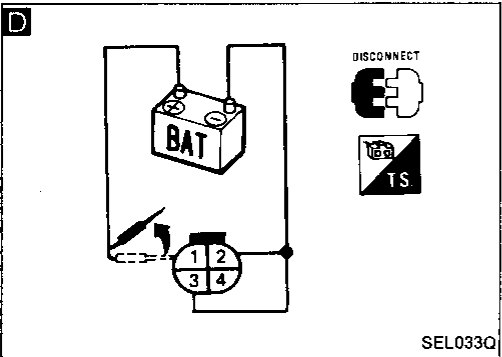
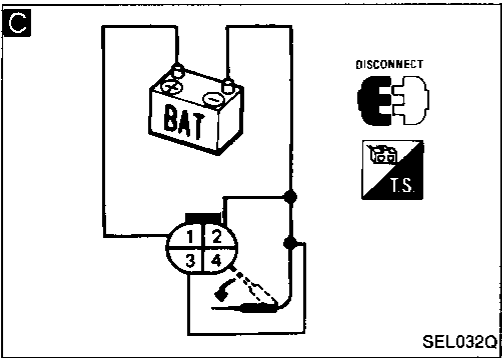
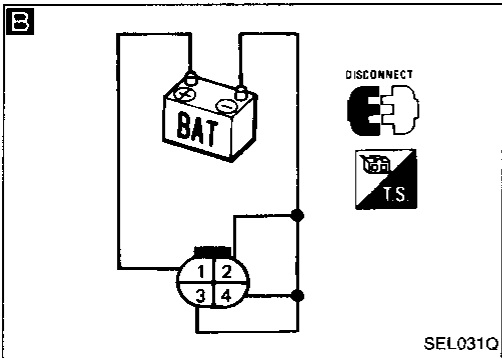
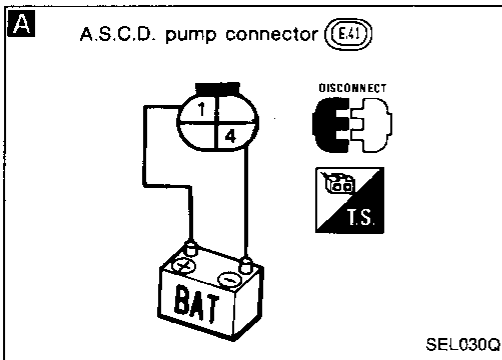

# AUTOMATIC SPEED CONTROL DEVICE (A.S.C.D.)

## A.S.C.D. Wire Adjustment (Cont'd)

### A.S.C.D. main switch

Check continuity between terminals by pushing switch to each position.

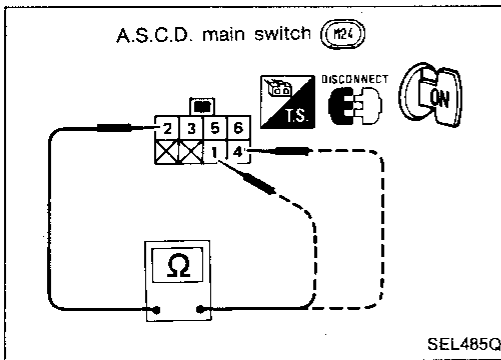

### A.S.C.D. steering switch

Check continuity between terminals by pushing each button.

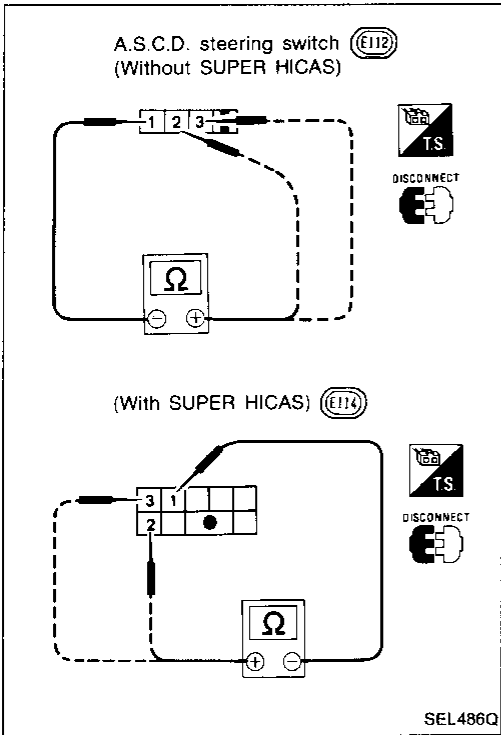

Terminal	1	2	3
Button			
SET/COAST	○	○	
RESUME/ACCEL	○		○
CANCEL	○	▶	
	○	▶	○

### A.S.C.D. cancel switch and stop lamp switch

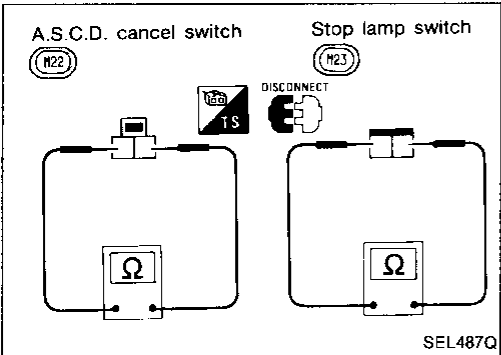

Condition	Continuity	
	A.S.C.D. cancel switch	Stop lamp switch
When brake pedal is depressed	No	Yes
When brake pedal is released	Yes	No

Check each switch after adjusting brake pedal — refer to BR section.

### Clutch switch (For M/T models)

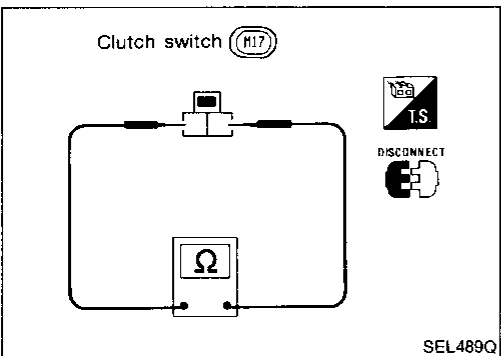

Condition	Continuity
When clutch pedal is depressed	No
When clutch pedal is released	Yes

Check switch after adjusting clutch pedal — refer to CL section.

GI

MA

EM

LC

EF & EC

FE

CL

MT

AT

PD

FA

RA

BR

ST

BF

HA

EL

# AUTOMATIC SPEED CONTROL DEVICE (A.S.C.D.)

## A.S.C.D. Wire Adjustment (Cont'd)

### Inhibitor switch (For A/T models)

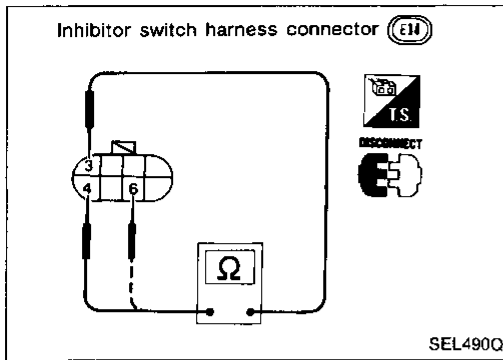

Terminal	3	4	6
Shift lever position			
"P"	○	○	
"N"	○		○
Except "N" or "P"			

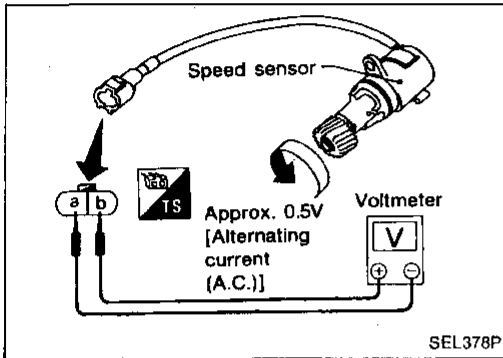

### Speed sensor

- 1 Remove speed sensor from transaxle.
- 2 Turn speedometer pinion quickly and measure voltage across **a** and **b**.

# LOCATION OF ELECTRICAL UNITS

## Engine Compartment

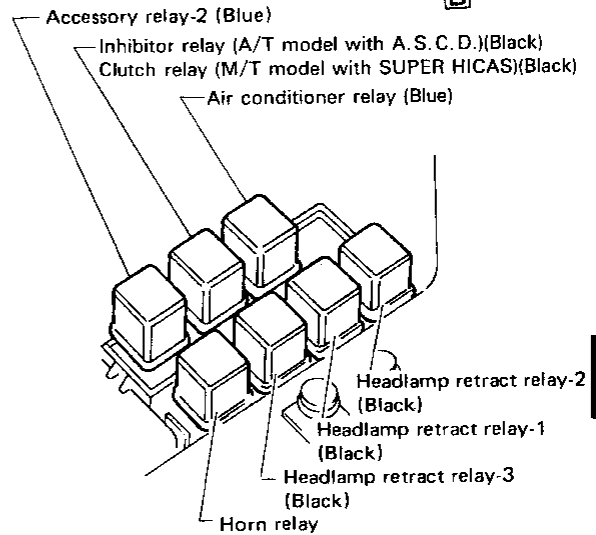
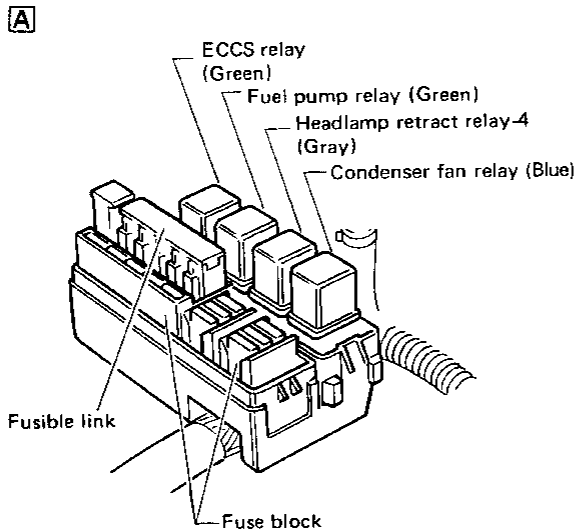
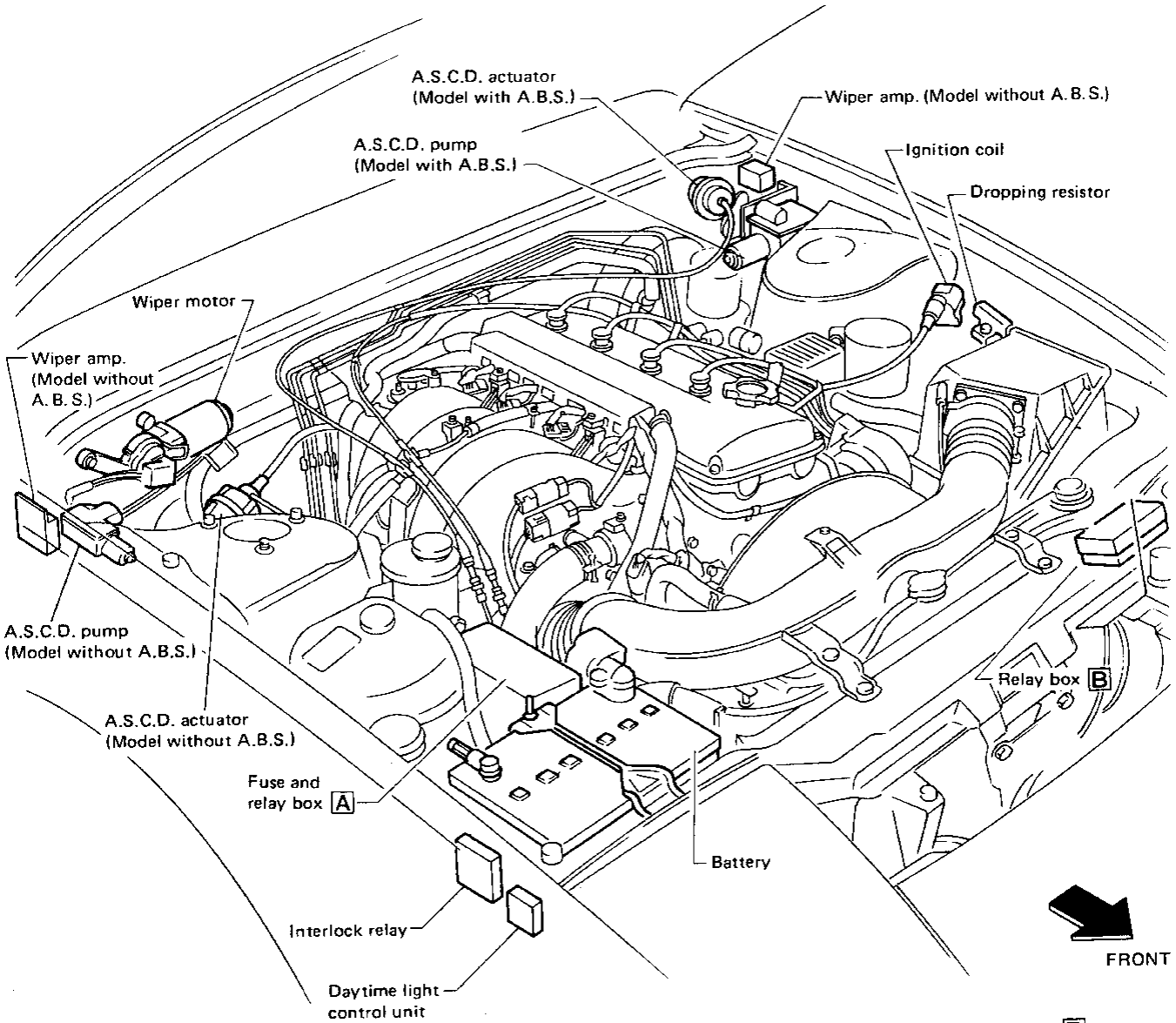

GI  
MA  
EM  
LC  
EF &  
EC  
FE  
CL  
NT  
AT  
PD  
FA  
RA  
BR  
ST  
BF  
HA  
EL

# LOCATION OF ELECTRICAL UNITS

## Passenger Compartment

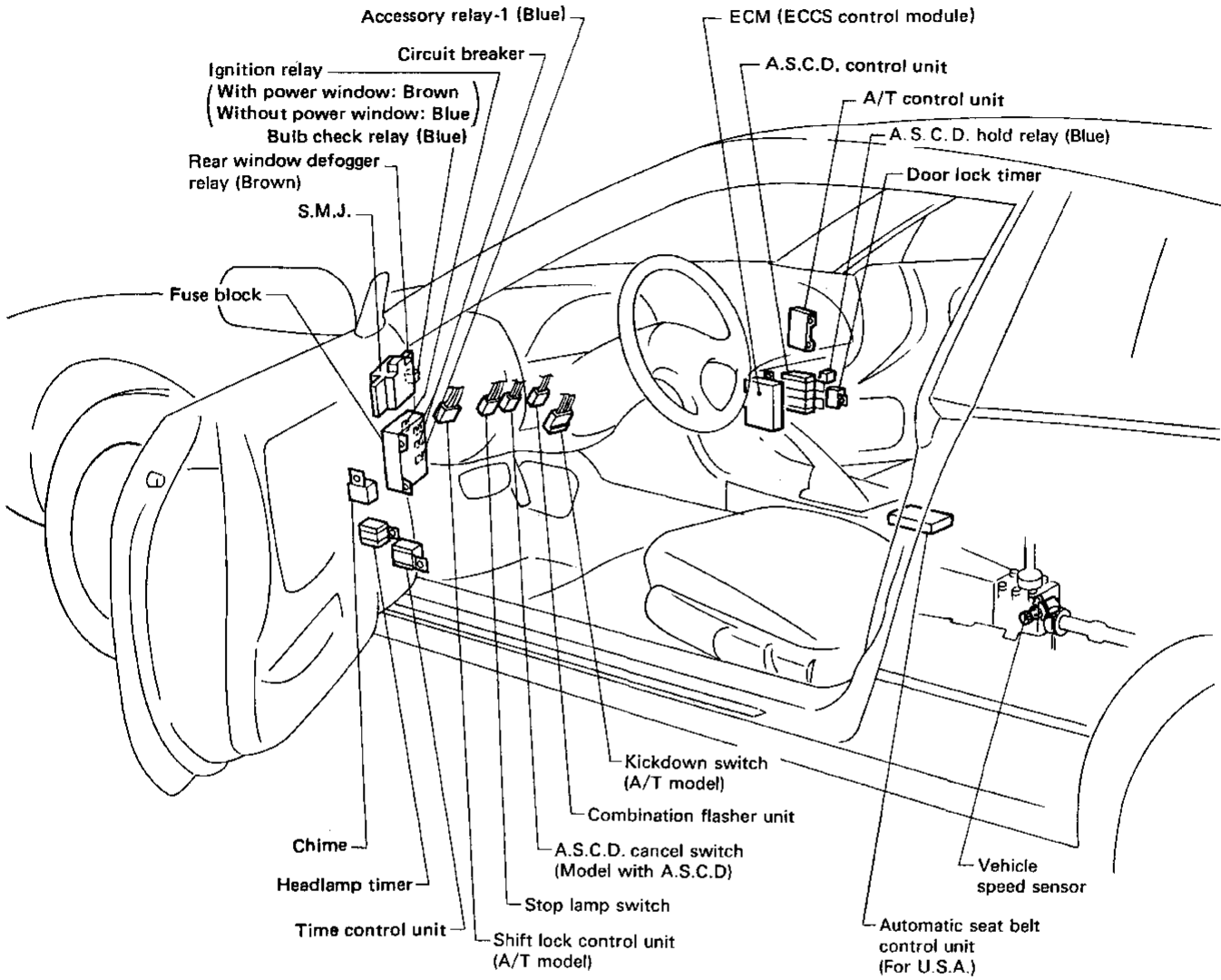



# LOCATION OF ELECTRICAL UNITS

## Passenger Compartment (Cont'd)

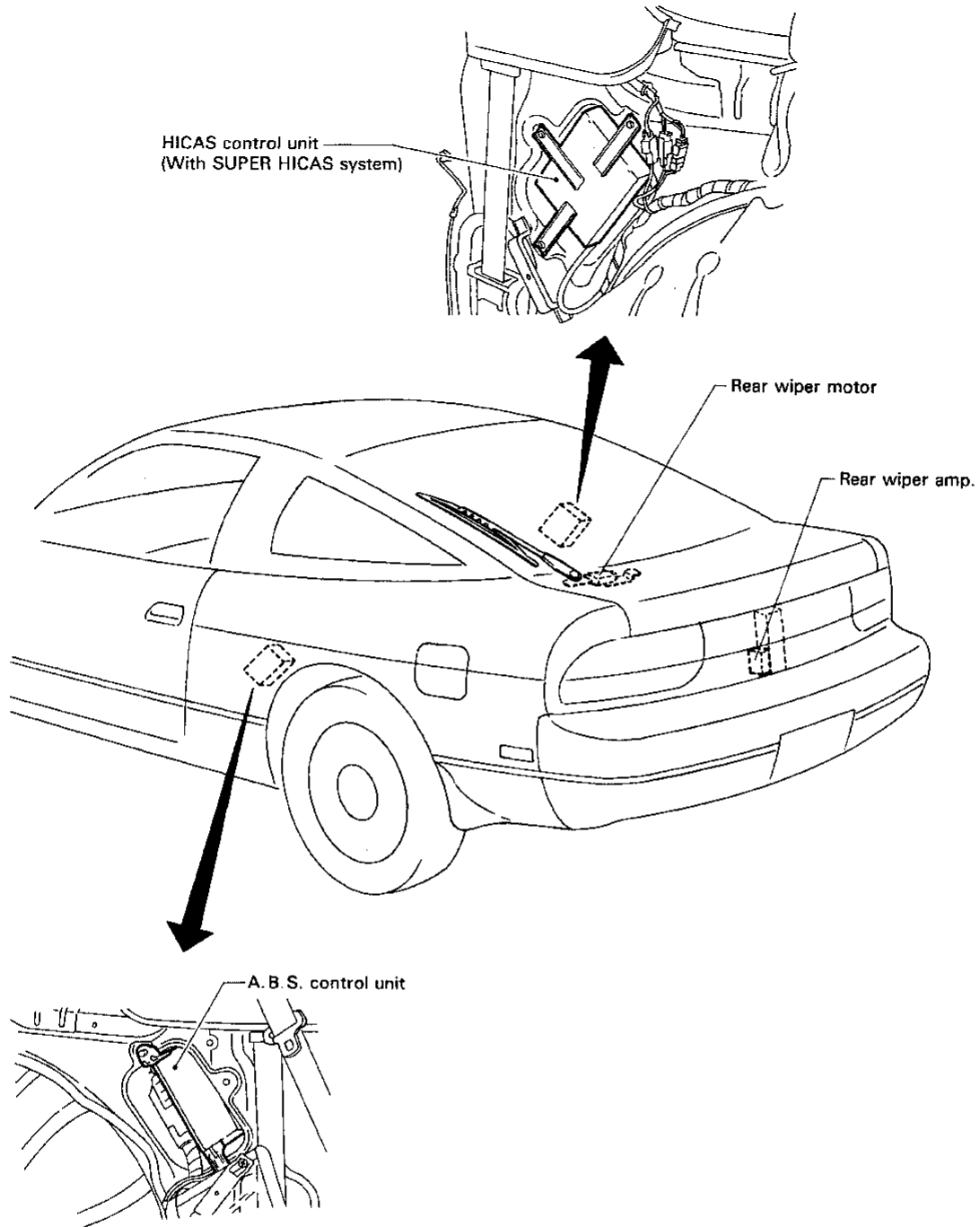

GI

MA

EM

LC

EF &  
EC

FE

CL

MT

AT

PD

FA

RA

BR

ST

BF

HA

**EL**

# HARNES LAYOUT

## Outline

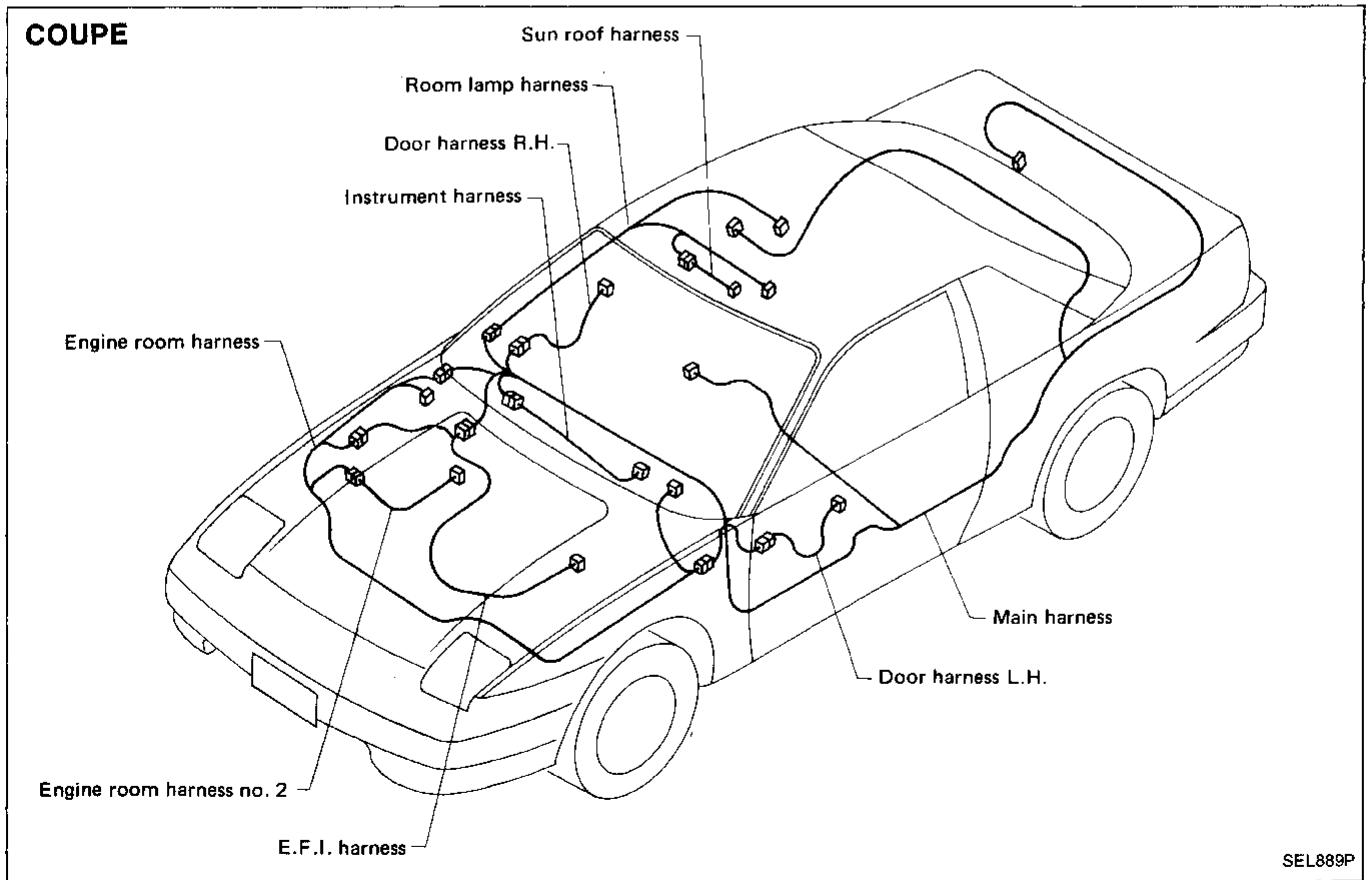
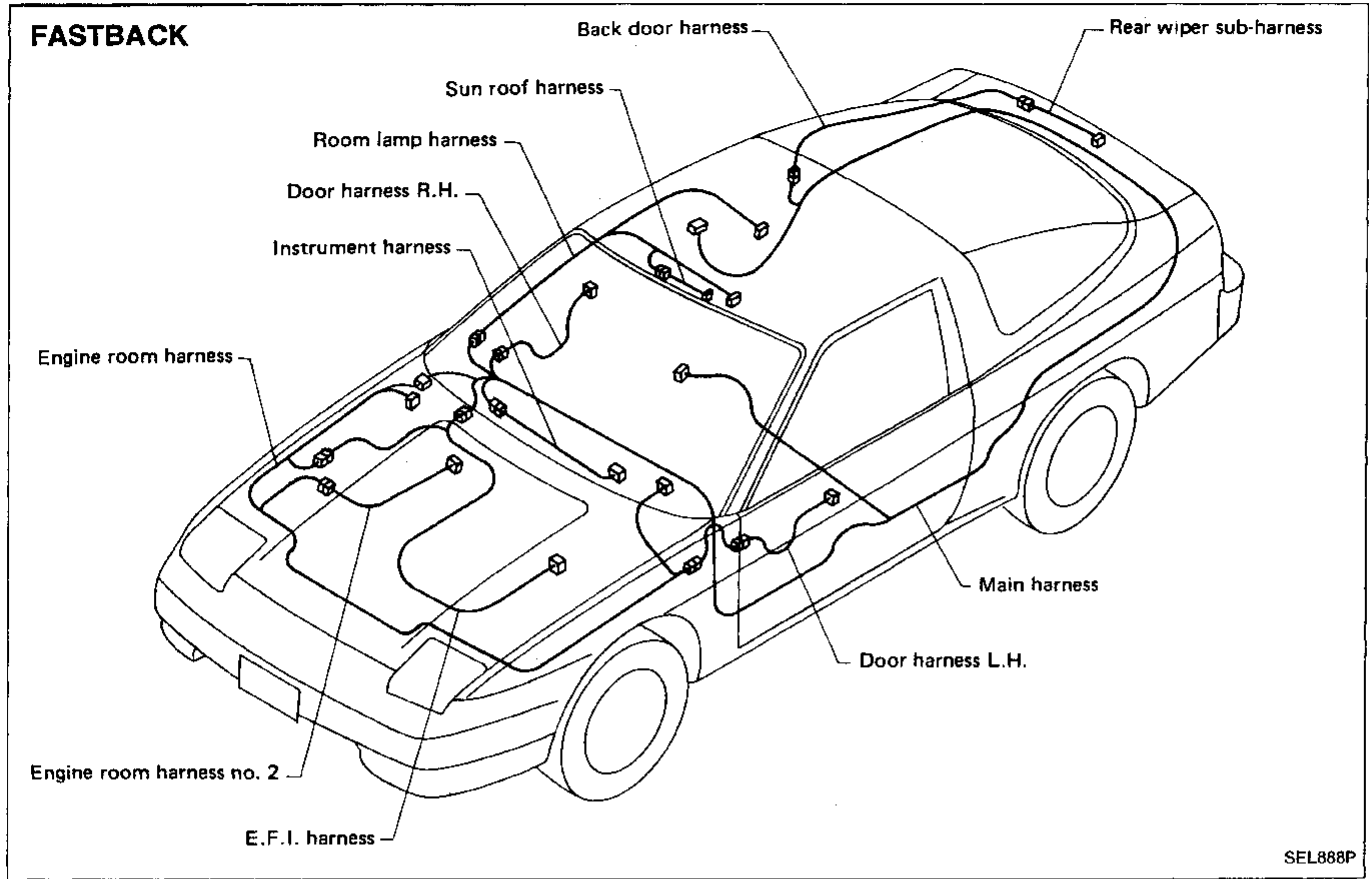

# HARNESS LAYOUT

## Instrument Harness

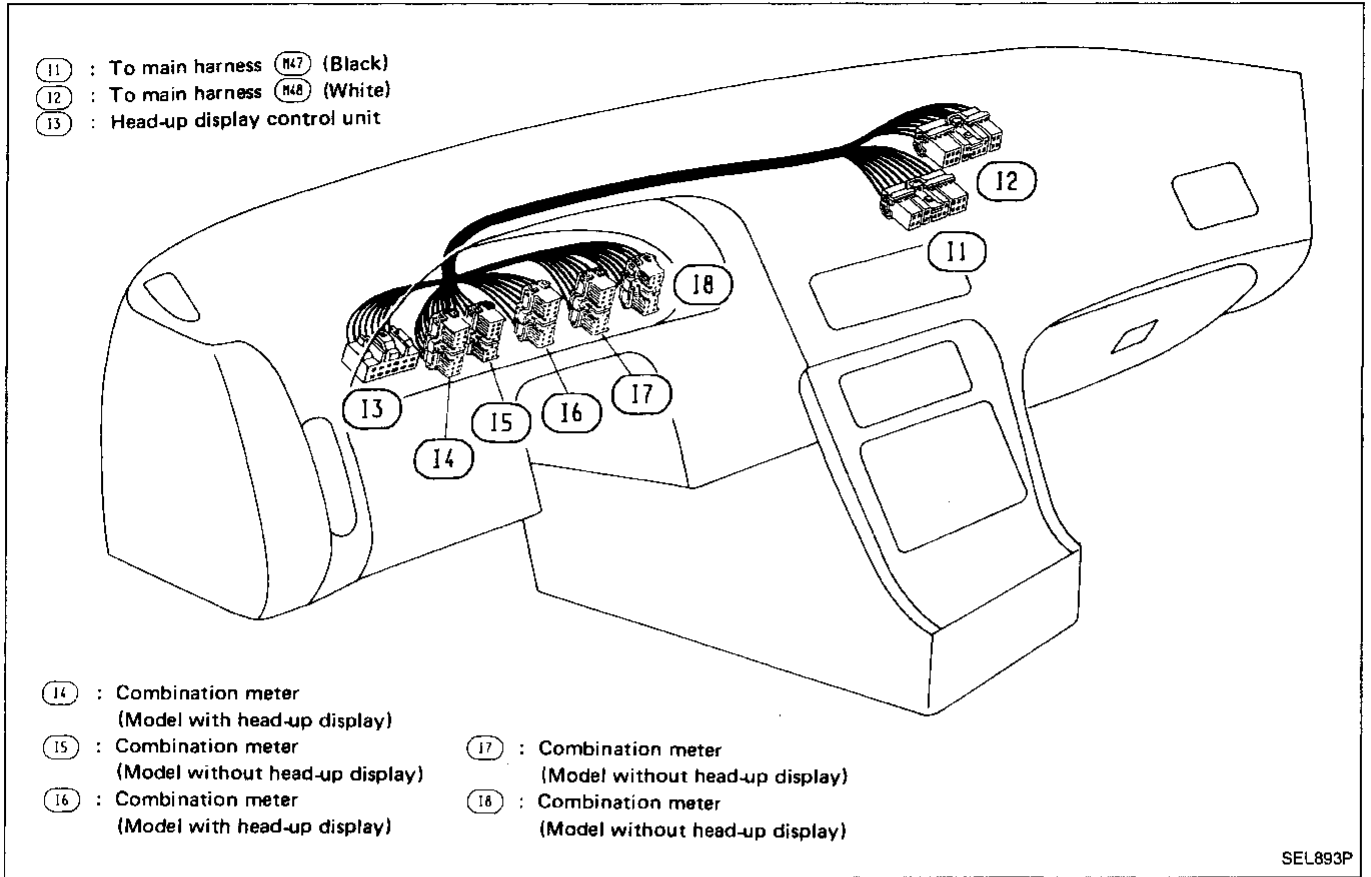

## Back Door Harness

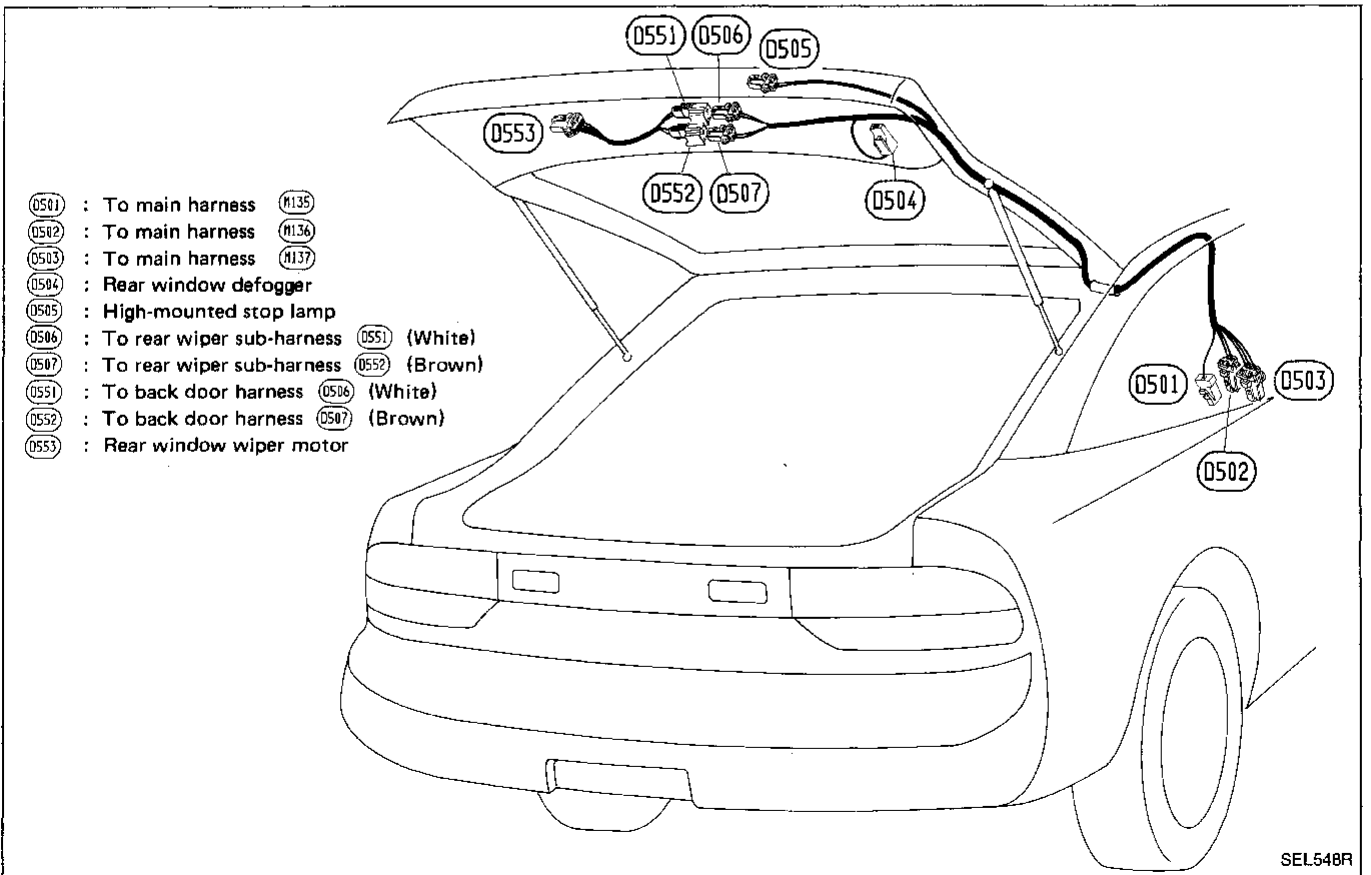

GI  
 MA  
 EM  
 LC  
 EF &  
 EC  
 FE  
 CL  
 MT  
 AT  
 PD  
 FA  
 RA  
 BR  
 ST  
 BF  
 HA  
 EL

# HARNESS LAYOUT

## Main Harness

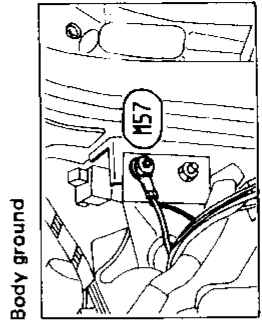
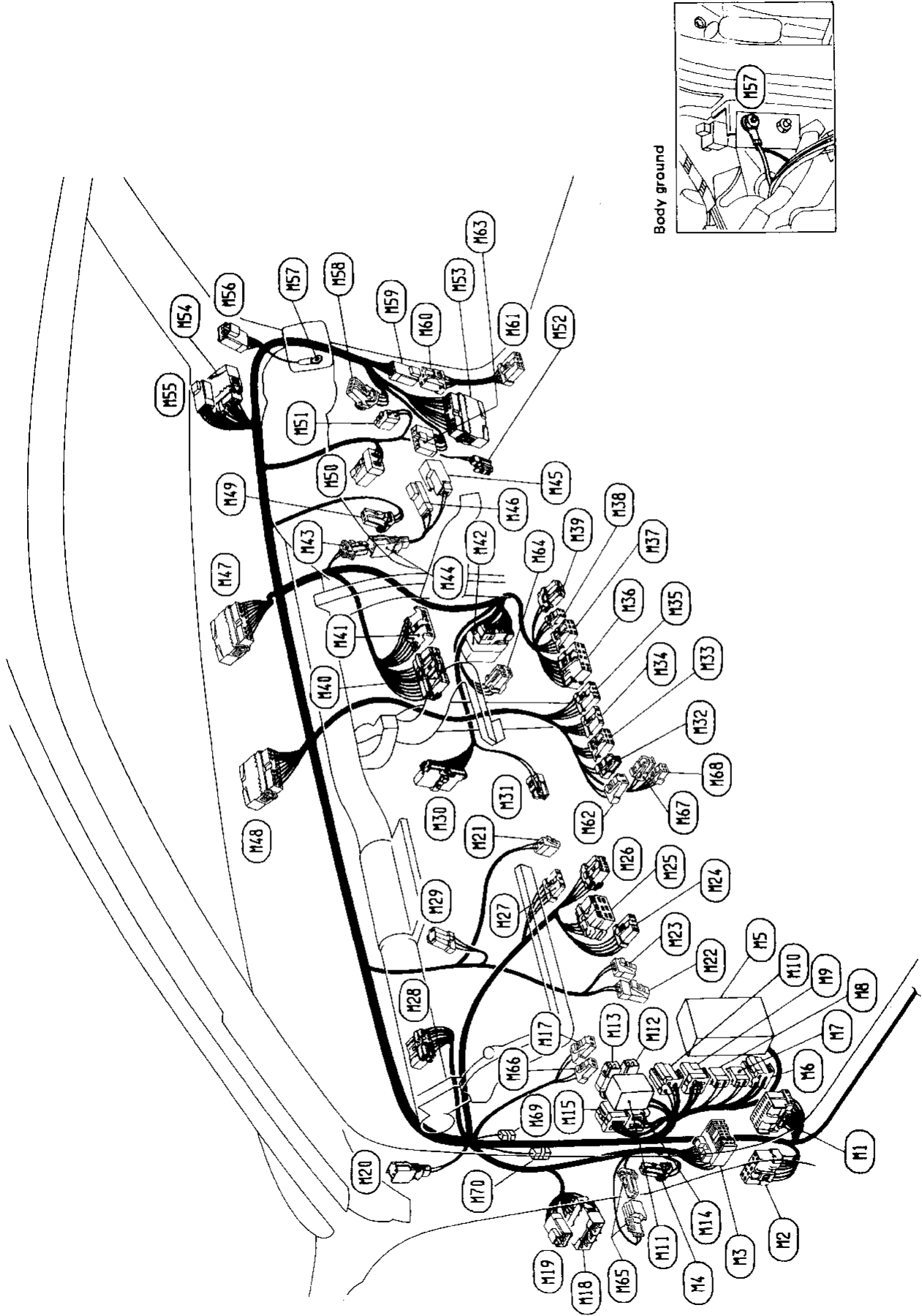

# HARNES LAYOUT

## Main Harness (Cont'd)

- (H1) : Time control unit
- (H2) : Headlamp timer
- (H3) : Data link connector for CONSULT
- (H4) : Warning chime
- (H5) : Fuse block
- (H6) : Accessory relay-1
- (H7) : Circuit breaker (Model with power window system)
- (H8) : Circuit breaker (For U.S.A.)
- (H9) : Ignition relay (Model with power window system)
- (H10) : Ignition relay (Model without power window system)
- (H11) : To engine room harness (E10) (S. M. J.)
- (H12) : To engine room harness (E102) (Blue)
- (H13) : To engine room harness (E103) (Black)
- (H14) : Bulb check relay
- (H15) : Rear window defogger relay
- (H17) : A.S.C.D. clutch switch (M/T model with A.S.C.D.)
- (H18) : To door harness L.H. (D1)
- (H19) : To door harness L.H. (D2)
- (H20) : Driver side front limit switch (For U.S.A.)
- (H21) : Kickdown switch (A/T model)
- (H22) : A.S.C.D. cancel switch (Model with A.S.C.D.)
- (H23) : Stop lamp switch
- (H24) : A.S.C.D. main switch (Model with A.S.C.D.)
- (H25) : Headlamp retractor switch
- (H26) : Illumination control switch
- (H27) : Not used
- (H29) : Shift lock control unit (A/T model)
- (H30) : Combination flasher unit
- (H31) : Mode door motor
- (H32) : Foot lamp L.H.
- (H33) : O. D. off indicator lamp (A/T model without SUPER HICAS system)
- (H34) : Rear wiper and washer switch
- (H35) : Rear window defogger switch
- (H36) : Hazard switch
- (H37) : Radio
- (H38) : Radio
- (H39) : Cassette deck
- (H40) : Cassette deck
- (H41) : Push control unit
- (H42) : Fan switch
- (H43) : Diode
- (H44) : To sub-harness (H4)
- (H45) : To main harness (H3)
- (H46) : Glove box lamp
- (H47) : Glove box lamp switch
- (H48) : To instrument harness (I1) (Black)
- (H49) : To instrument harness (I2) (White)
- (H50) : Thermo control amplifier
- (H51) : Heater resistor
- (H52) : Blower motor

- (M62) : Foot lamp R.H.
- (M63) : To E.F.I. harness (E1)
- (M64) : To door harness R.H. (D101)
- (M65) : To door harness R.H. (D102)
- (M66) : To room lamp harness (R1)
- (M67) : Body ground
- (M68) : Intake door motor
- (M69) : To sub-harness (H3)
- (M70) : To main harness (H5)
- (M71) : Door lock timer

- (E119) : Washer warning lamp (Model with A.S.C.D.)
- (E120) : To engine room harness
- (E121) : Blower relay
- (E122) : Joint connector (Model with SUPER HICAS system)
- (E123) : HICAS clutch switch (M/T model with SUPER HICAS system)
- (E124) : HICAS warning lamp (M/T model with SUPER HICAS system)
- (E125) : O. D. off indicator and HICAS warning lamp (A/T model with SUPER HICAS system)
- (E126) : Diode (For Canada)
- (E127) : Diode (For Canada)

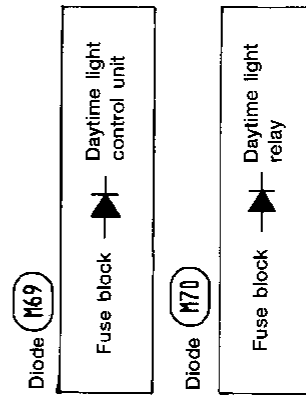
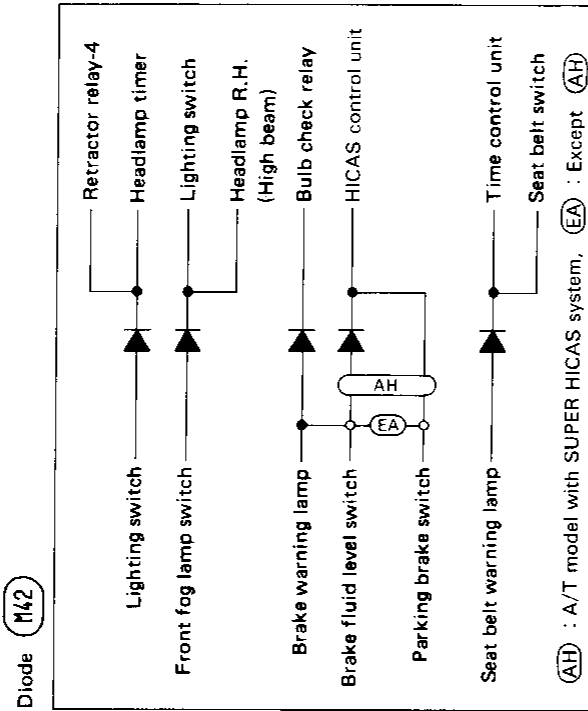

GI  
 MA  
 EM  
 LC  
 EF & EC  
 FE  
 CL  
 MT  
 AT  
 PD  
 FA  
 RA  
 BR  
 ST  
 BF  
 HA  
 EL

# HARNESS LAYOUT

## Main Harness (Cont'd)

FASTBACK

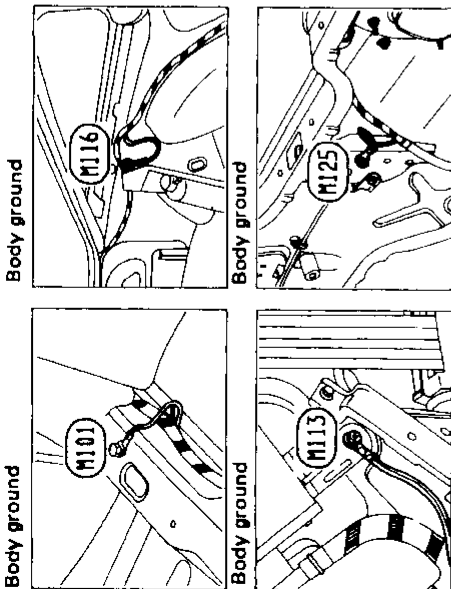
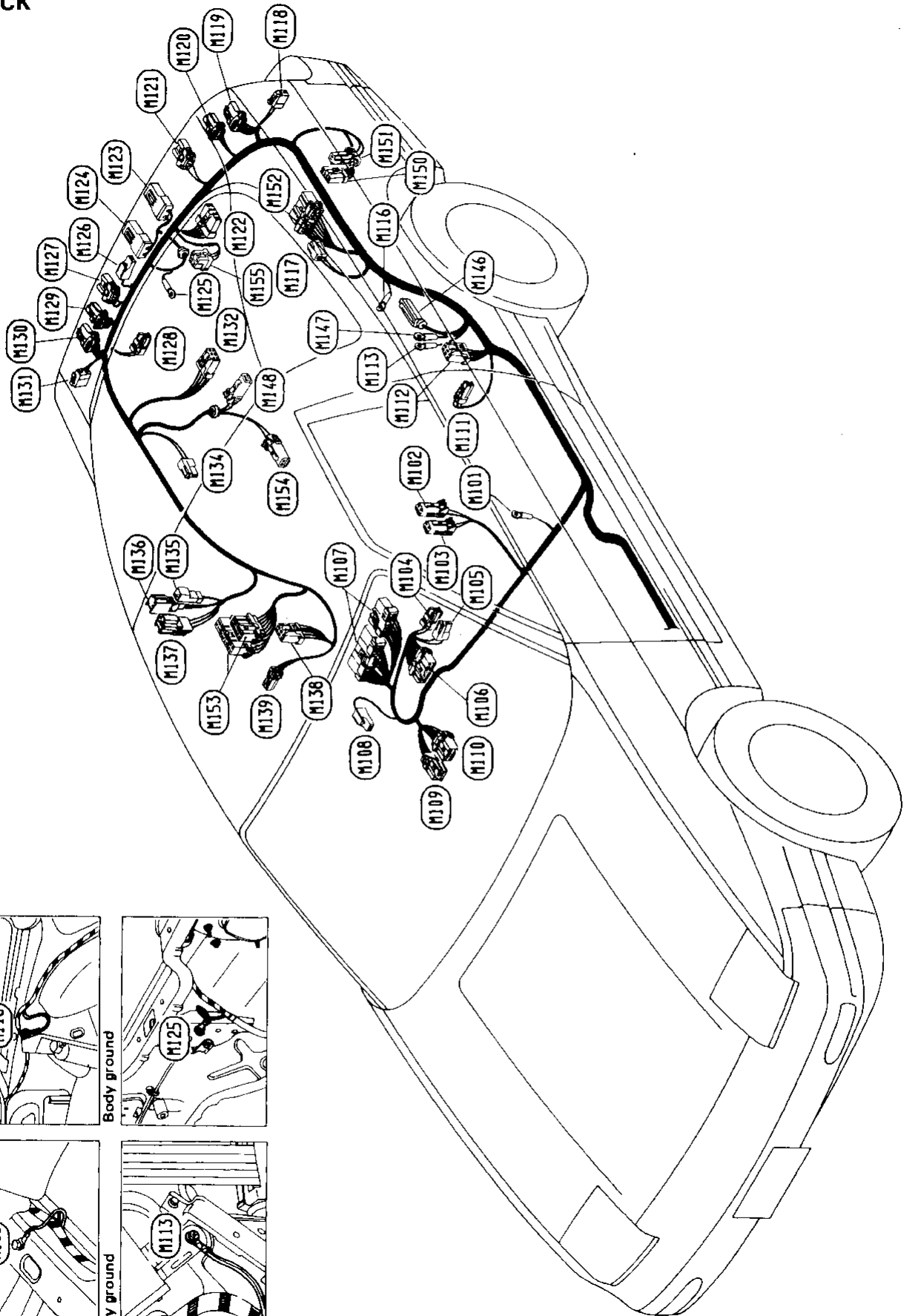

# HARNES LAYOUT

## Main Harness (Cont'd)

- (M101) : Body ground
- (M102) : Lap belt buckle switch (For U.S.A.)
- (M103) : Seat belt switch (For Canada)
- (M104) : Ash tray illumination
- (M105) : Cigarette lighter
- (M106) : Door mirror control switch
- (M107) : Automatic seat belt control unit (For U.S.A.)
- (M108) : Parking brake switch
- (M109) : A/T device (A/T illumination and O.D. control switch) (A/T model)
- (M110) : Shift lock solenoid (A/T model)
- (M111) : Door switch L.H.
- (M112) : Automatic seat belt motor assembly L.H. (For U.S.A.)
- (M113) : Body ground (For U.S.A.)
- (M116) : Body ground
- (M117) : Rear speaker L.H.
- (M118) : Rear side marker lamp L.H.
- (M119) : Rear combination lamp L.H.

- (M120) : Rear combination lamp L.H.
- (M121) : Back-up lamp L.H.
- (M122) : Rear wiper amplifier
- (M123) : License lamp L.H.
- (M124) : License lamp R.H.
- (M125) : Body ground
- (M126) : Luggage room lamp switch
- (M127) : Back-up lamp R.H.
- (M128) : Luggage room lamp
- (M129) : Rear combination lamp R.H.
- (M130) : Rear combination lamp R.H.
- (M131) : Rear side marker lamp R.H.
- (M132) : Fuel tank gauge unit
- (M134) : Rear speaker R.H.
- (M135) : To back door harness (0501)
- (M136) : To back door harness (0502)
- (M137) : To back door harness (0503)
- (M138) : Automatic seat belt motor assembly R.H. (For U.S.A.)
- (M139) : Door switch R.H.
- (M146) : A.B.S. control unit (For Anti-lock Braking System)
- (M147) : Body ground (For Anti-lock Braking System)
- (M148) : Rear sensor (For Anti-lock Braking System)
- (M149) : Auto antenna timer
- (M151) : Auto antenna motor
- (M152) : Rear speaker amplifier (Active speaker type)
- (M159) : HICAS control unit (With SUPER HICAS system)
- (M154) : HICAS fail safe solenoid valve (With SUPER HICAS system)
- (M155) : Daytime light relay (For Canada)

GI  
MA  
EM  
LC  
EF &  
EC  
FE  
CL  
MT  
AT  
PD  
FA  
RA  
BR  
ST  
BF  
HA

EL

# HARNES LAYOUT

## Main Harness (Cont'd)

COUPE

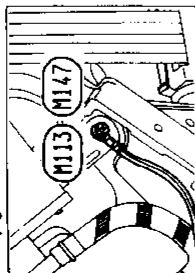
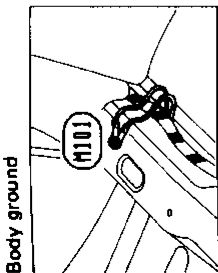
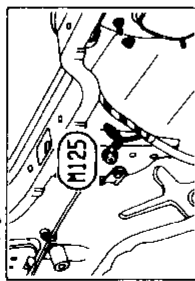
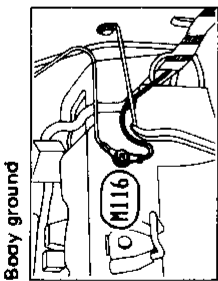
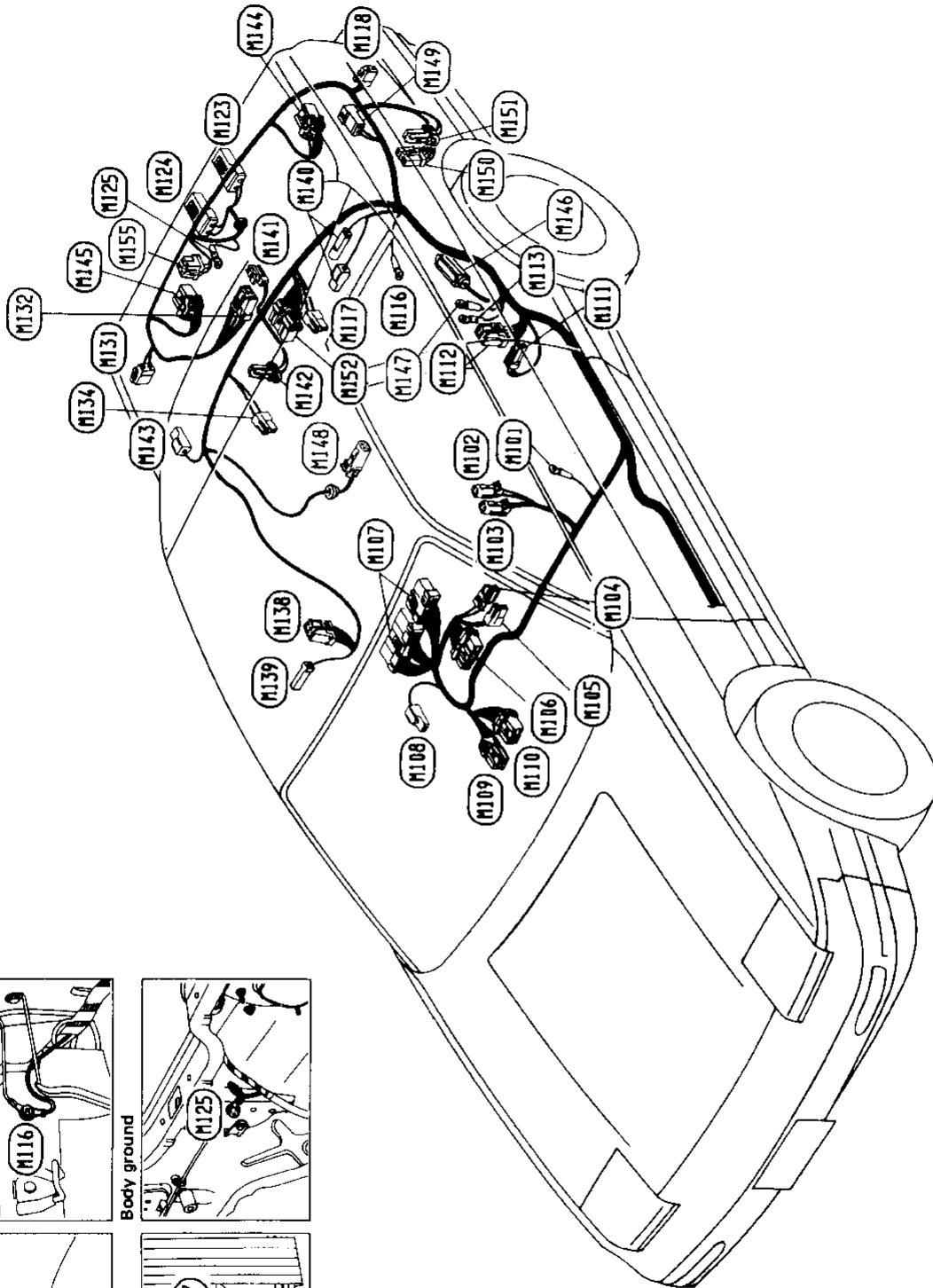



# HARNES LAYOUT

## Main Harness (Cont'd)

- ①101 : Body ground
- ①102 : Lap belt buckle switch (For U.S.A.)
- ①103 : Seat belt switch (For Canada)
- ①104 : Ash tray illumination
- ①105 : Cigarette lighter
- ①106 : Door mirror control switch
- ①107 : Automatic seat belt control unit (For U.S.A.)
- ①108 : Parking brake switch
- ①109 : A/T device (A/T illumination and O.D. control switch) (A/T model)
- ①110 : Shift lock solenoid (A/T model)
- ①111 : Door switch L.H.
- ①112 : Automatic seat belt motor assembly L.H. (For U.S.A.)
- ①113 : Body ground (For U.S.A.)
- ①116 : Body ground
- ①117 : Rear speaker L.H.
- ①118 : Rear side marker lamp L.H.
- ①123 : License lamp L.H.
- ①124 : License lamp R.H.
- ①125 : Body ground
- ①131 : Rear side marker lamp R.H.
- ①132 : Fuel tank gauge unit
- ①134 : Rear speaker R.H.
- ①138 : Automatic seat belt motor assembly R.H. (For U.S.A.)
- ①139 : Door switch R.H.
- ①140 : Trunk room lamp switch
- ①141 : Trunk room lamp
- ①142 : High-mounted stop lamp (Model without rear spoiler)
- ①143 : Rear window defogger
- ①144 : Rear combination lamp L.H.
- ①145 : Rear combination lamp R.H.
- ①146 : A.B.S. control unit (For Anti-lock Braking System)
- ①147 : Body ground (For Anti-lock Braking System)
- ①148 : Rear sensor (For Anti-lock Braking System)
- ①149 : To high-mounted stop lamp sub-harness (Model with rear spoiler)
- ①150 : Auto antenna timer
- ①151 : Auto antenna motor
- ①152 : Rear speaker amplifier (Active speaker type)
- ①155 : Daytime light relay (For Canada)

GI  
MA  
EM  
LC  
EF &  
EC  
FE  
CL  
MT  
AT  
PD  
FA  
RA  
BR  
ST  
BF  
HA  
EL

# HARNESS LAYOUT

## Engine Room Harness

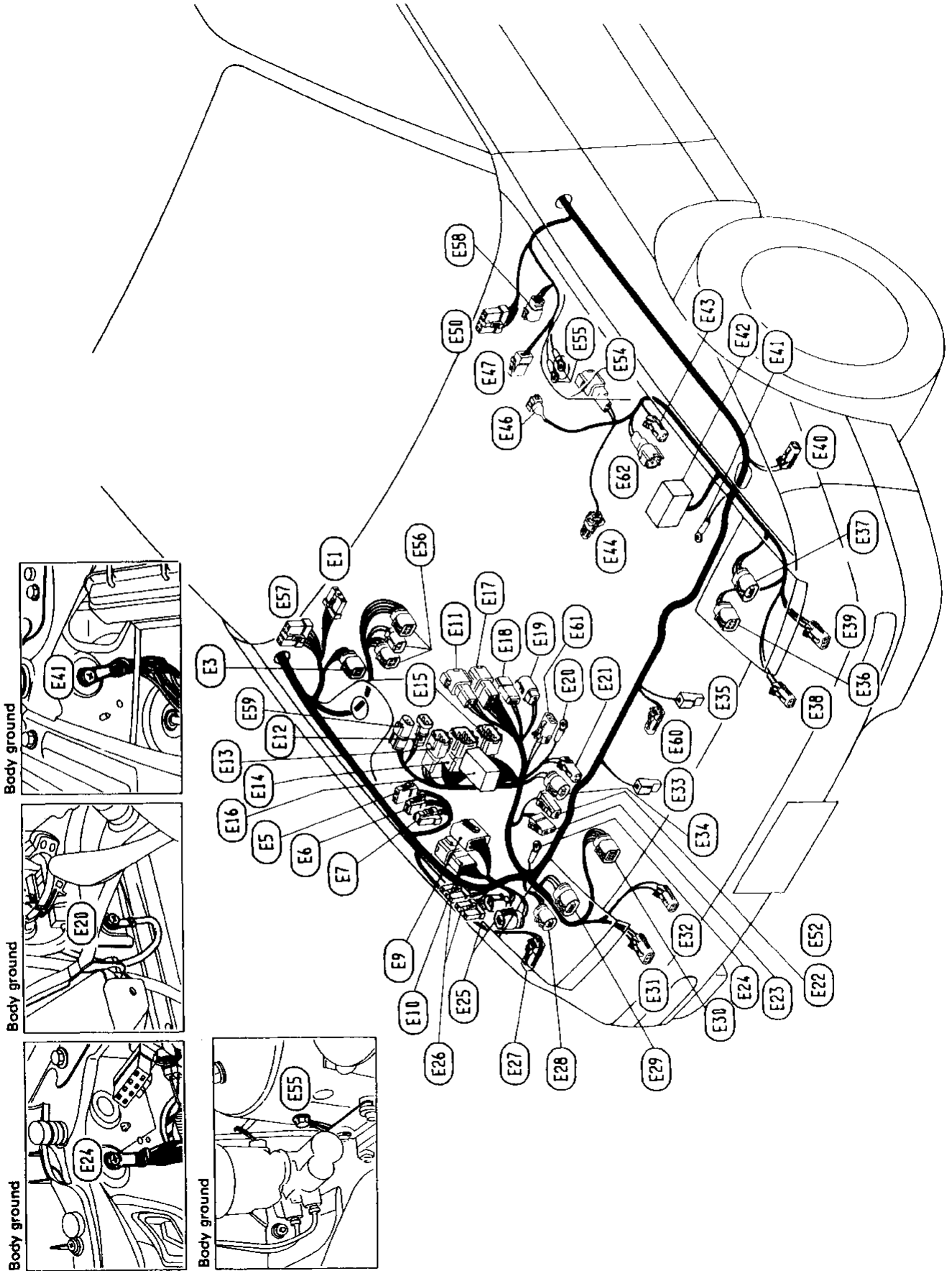

# HARNES LAYOUT

## Engine Room Harness (Cont'd)

- (E1) : Windshield wiper motor
- (E3) : A.S.C.D. actuator (Model without Anti-lock Braking System)
- (E5) : Rear washer motor
- (E6) : Front washer motor
- (E7) : Washer fluid level switch
- (E9) : To E.F.I. harness (E8) (White)
- (E10) : To E.F.I. harness (F9) (Brown)
- (E11) : To engine room harness no. 2 (E201) (A/T model)
- (E12) : Inhibitor switch (A/T model)
- (E13) : Revolution sensor (A/T model)
- (E14) : Inhibitor switch (A/T model) (Gray)
- (E15) : To solenoid valve sub-harness (A/T model) (Brown)
- (E16) : Relay box (Refer to page EL-97.)
- (E17) : To engine room harness no. 2 (E202)
- (E18) : To engine room harness no. 2 (E203)
- (E19) : To engine room harness no. 2 (E204)
- (E20) : Body ground
- (E21) : Dual-pressure switch
- (E22) : Battery
- (E23) : Battery
- (E24) : Body ground
- (E25) : Interlock relay (M/T model for U.S.A.) U.S.A.)
- (E26) : Daytime light control unit (For Canada)
- (E27) : Front side marker lamp R.H.
- (E28) : Not used
- (E29) : Headlamp R.H.
- (E30) : Headlamp motor R.H.
- (E31) : Front combination lamp R.H.
- (E32) : Daytime light R.H. (For Canada)
- (E33) : Horn-low
- (E34) : Condenser fan motor
- (E35) : Horn-high
- (E36) : Headlamp motor L.H.
- (E37) : Headlamp L.H.
- (E38) : Daytime light L.H. (For Canada)
- (E39) : Front combination lamp L.H.
- (E40) : Front side marker lamp L.H.
- (E41) : Body ground
- (E42) : Relay box (Refer to page EL-97.)
- (E43) : Dropping resistor (A/T model.)
- (E44) : Compressor
- (E46) : PAIRC-solenoid valve
- (E47) : Brake fluid level switch
- (E50) : Windshield wiper amplifier (Model without Anti-lock Braking System)
- (E54) : Front wheel sensor L.H. (For Anti-lock Braking System)
- (E55) : Body ground
- (E56) : Actuator (For Anti-lock Braking System)
- (E57) : Windshield wiper amplifier (Model with Anti-lock Braking System)
- (E58) : A.S.C.D. actuator (Model with Anti-lock Braking System)
- (E59) : To engine room harness no.2 (E206) (M/T model)
- (E60) : Ambient switch
- (E61) : HICAS solenoid valve (With SUPER HICAS system)
- (E62) : HICAS oil level switch (With SUPER HICAS system)

GI  
MA  
EM  
LC  
EF & EC  
FE  
CL  
MT  
AT  
PD  
FA  
RA  
BR  
ST  
BF  
HA

EL

# HARNESS LAYOUT

## Engine Room Harness (Cont'd)

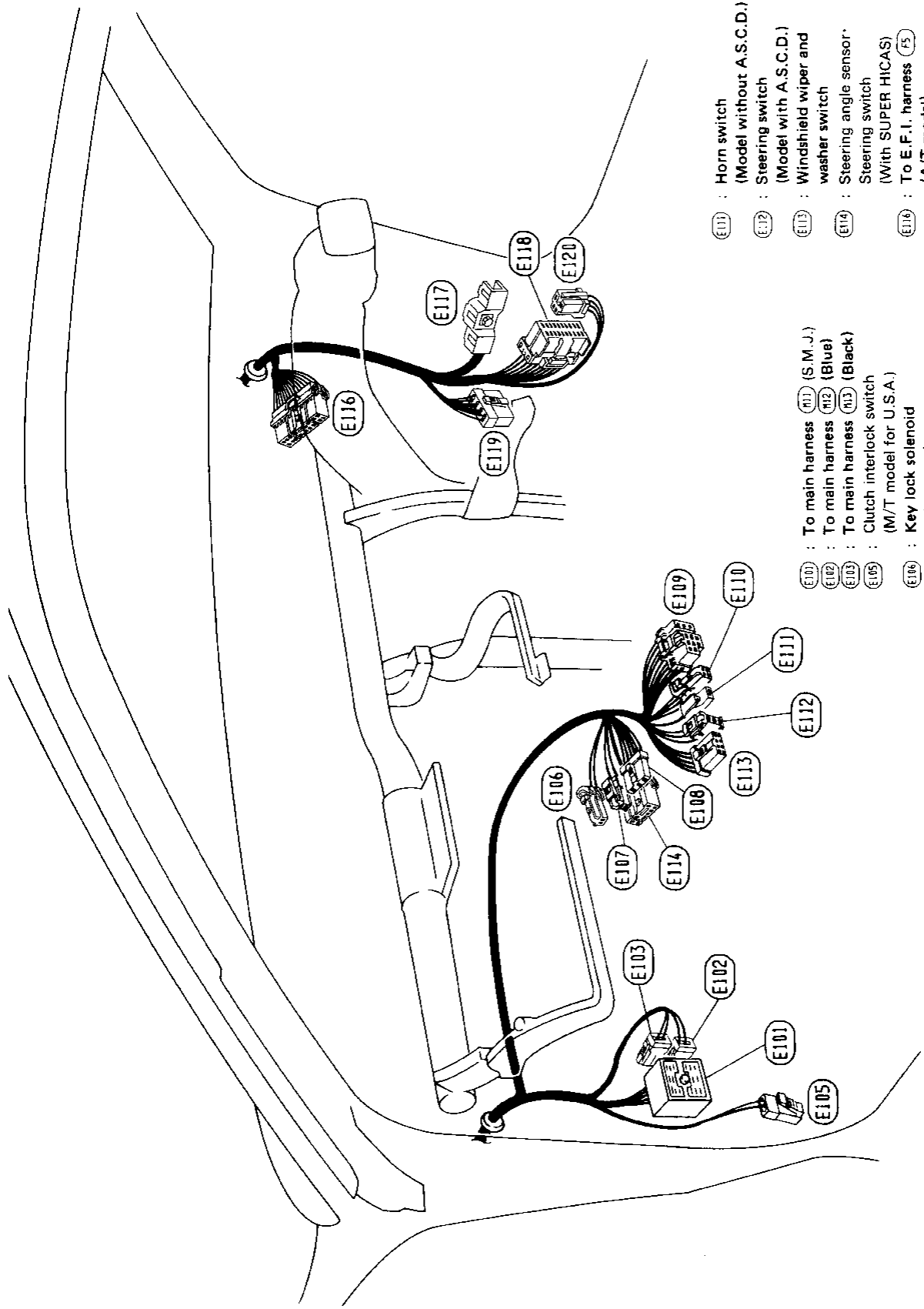

- (E11) : Horn switch  
(Model without A.S.C.D.)
- (E12) : Steering switch  
(Model with A.S.C.D.)
- (E13) : Windshield wiper and  
washer switch
- (E14) : Steering angle sensor-  
Steering switch  
(With SUPER HICAS)
- (E16) : To E.F.I. harness (F5)  
(A/T model)
- (E17) : A/T control unit
- (E18) : A.S.C.D. control unit
- (E19) : To main harness (K63)
- (E20) : A.S.C.D. hold relay

- (E10) : To main harness (H1) (S.M.J.)
- (E102) : To main harness (H12) (Blue)
- (E103) : To main harness (H13) (Black)
- (E105) : Clutch interlock switch  
(M/T model for U.S.A.)
- (E106) : Key lock solenoid  
(A/T model)
- (E107) : Key switch
- (E108) : Ignition switch
- (E109) : Combination switch
- (E110) : Combination switch

# HARNESS LAYOUT

## Engine Room Harness No. 2

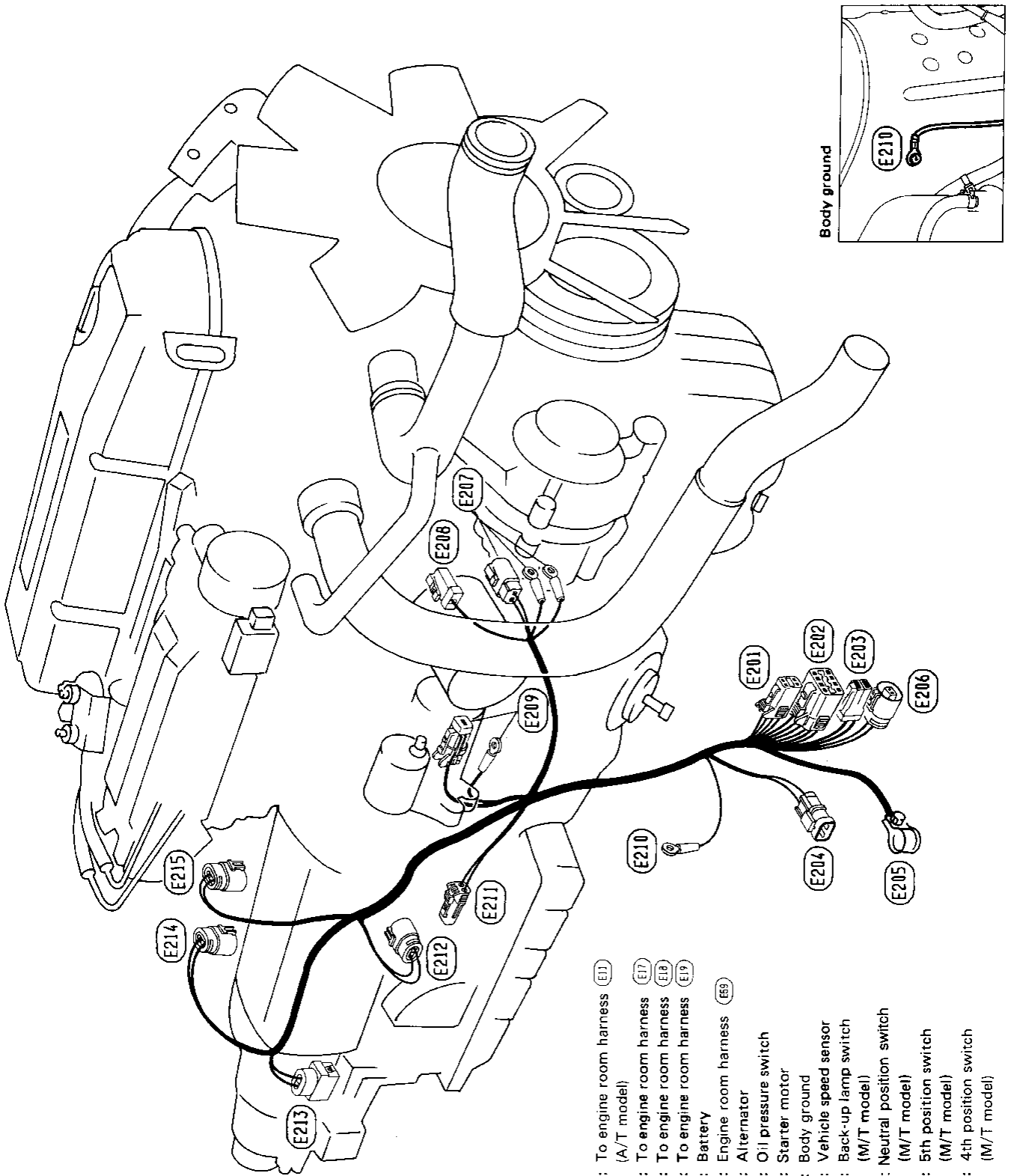

GI  
MA  
EM  
LC  
EF & EC  
FE  
CL  
MT  
AT  
PD  
FA  
RA  
BR  
ST  
BF  
HA

- (E20) : To engine room harness (E1) (A/T model)
- (E202) : To engine room harness (E17)
- (E203) : To engine room harness (E18)
- (E204) : To engine room harness (E19)
- (E205) : Battery
- (E206) : Engine room harness (E9)
- (E207) : Alternator
- (E208) : Oil pressure switch
- (E209) : Starter motor
- (E210) : Body ground
- (E211) : Vehicle speed sensor
- (E212) : Back-up lamp switch (M/T model)
- (E213) : Neutral position switch (M/T model)
- (E214) : 5th position switch (M/T model)
- (E215) : 4th position switch (M/T model)



# HARNESS LAYOUT

## E.F.I. Harness

### E.F.I. sub harness

- (F51) : To E.F.I. harness (F26)
- (F52) : EGR temperature sensor (For California)
- (F53) : IACV-Air regulator
- (F54) : IACV-FICD solenoid valve
- (F55) : IACV-AAC valve

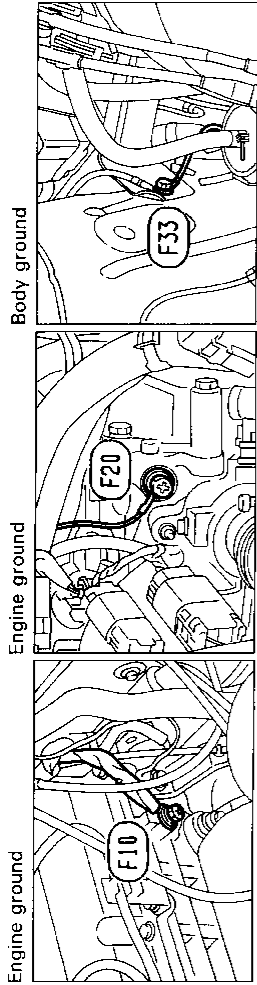

Diode (F3)

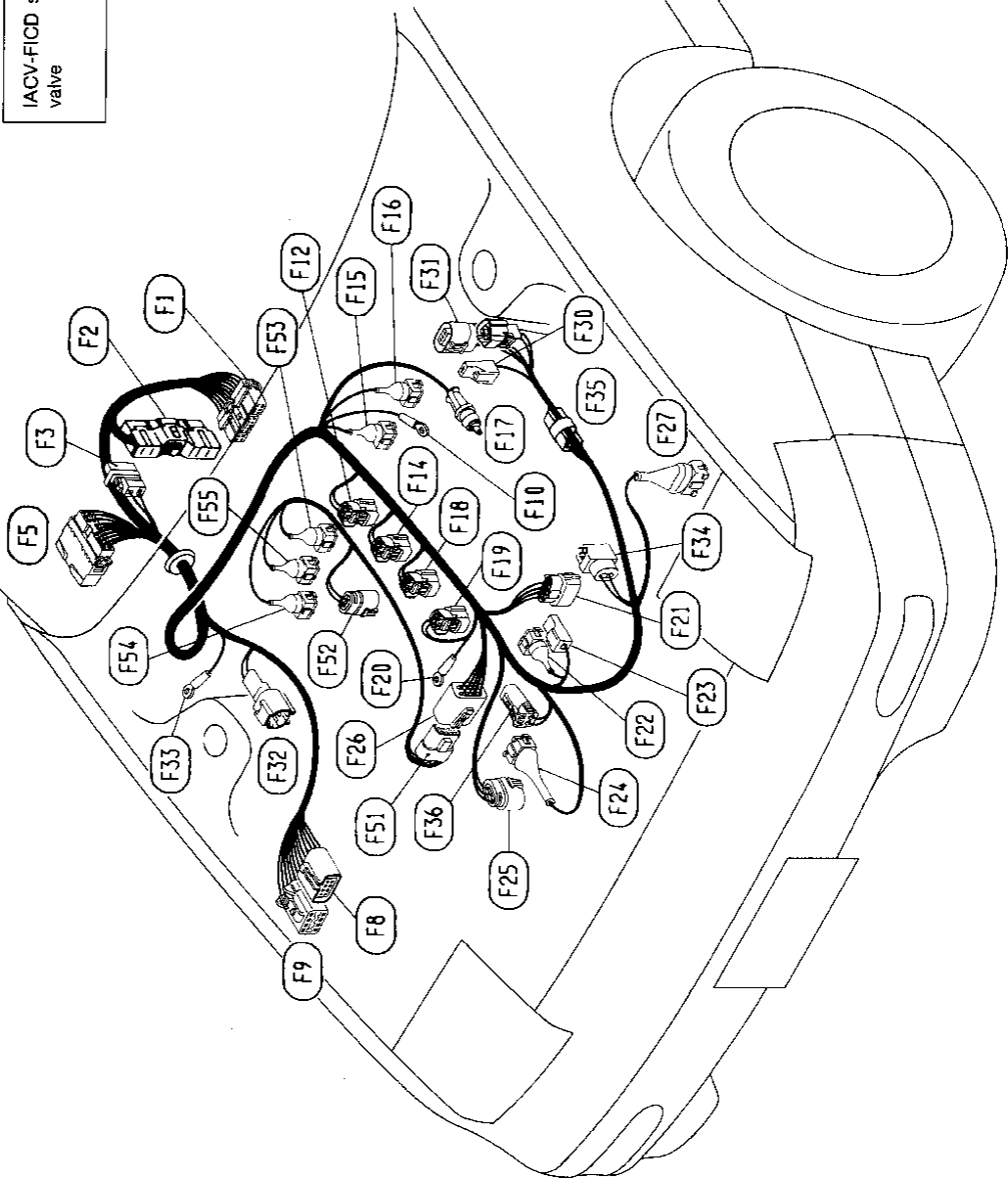
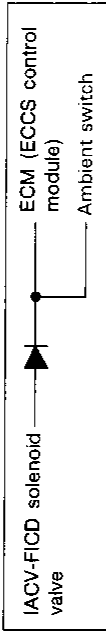

- (F1) : To main harness (F53)
- (F2) : ECM (ECCS control module)
- (F3) : Diode
- (F5) : To engine room harness (E15) (A/T model)
- (F8) : To engine room harness (E9) (White)
- (F9) : To engine room harness (E10) (Brown)
- (F10) : Engine ground
- (F12) : Injector no. 4
- (F14) : Injector no. 3
- (F15) : E.G.R. control solenoid valve
- (F16) : S.C.V. control solenoid valve
- (F17) : Exhaust gas sensor
- (F18) : Injector no. 2
- (F19) : Injector no. 1
- (F20) : Engine ground
- (F21) : Crankshaft position sensor
- (F22) : Engine coolant temperature sensor
- (F23) : Thermal transmitter
- (F24) : Throttle position switch
- (F25) : Throttle position sensor
- (F26) : To E.F.I. sub harness (F51)
- (F27) : Mass air flow sensor
- (F30) : Ignition coil
- (F31) : Power transistor
- (F32) : Front wheel sensor R.H. (For Anti-lock Braking System)
- (F33) : Body ground (For Anti-lock Braking System)
- (F34) : Power steering oil pressure switch
- (F35) : Resistor and condenser
- (F36) : To knock sensor sub harness

# HARNES LAYOUT

## Room Lamp and Sun Roof Harness



Body ground

- Sun roof harness**
- (R1) : To room lamp harness
  - (R2) : To room lamp harness
  - (S1) : Body ground
  - (S2) : Sun roof switch
  - (S3) : Sun roof switch
  - (S4) : Slide relay — open
  - (S5) : Sun roof motor
  - (S6) : Safety relay
  - (S7) : Slide relay — close
  - (S8) : Safety limit switch

- Room lamp harness**
- (R1) : To main harness (156)
  - (R2) : To sun roof harness (S1)
  - (R3) : Spot lamp (Model with sun roof)
  - (R4) : Interior lamp (Model without sun roof)
  - (R5) : Interior lamp (Fastback with sun roof)
  - (R6) : Interior lamp (Coupe with sun roof)
  - (R8) : Automatic seat belt front limit switch (For U.S.A.)

GI  
MA  
EM  
LC  
EF &  
EC  
FE  
CL  
MT  
AT  
PD  
FA  
RA  
BR  
ST  
BF  
HA

EL

# HARNESS LAYOUT

## Door Harness L.H.

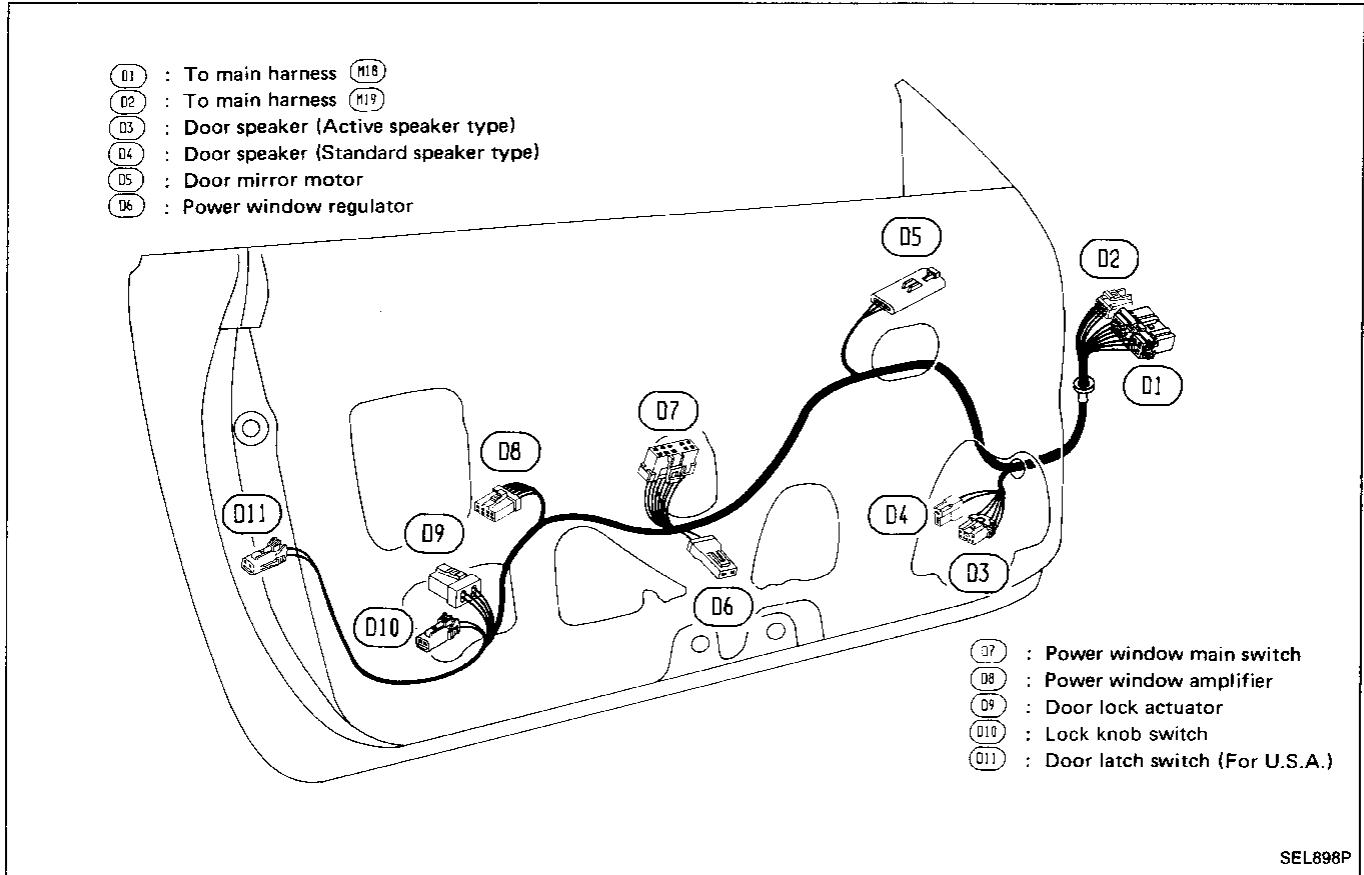

## Door Harness R.H.

